

**Environmental Effects of
Hydrokinetic Turbines on Fish:
Desktop and Laboratory Flume Studies
2012**

Project Manager: Paul T. Jacobson¹

Principal Investigators: Stephen V. Amaral²
Theodore Castro-Santos³
Dan Giza²
Alexander J. Haro³
George Hecker²
Brian McMahon²
Norman Perkins²
Nick Pioppi²

¹ Electric Power Research Institute

² Alden Research Laboratory

³ U.S.G.S. S.O. Conte Anadromous Fish Research Laboratory

Executive Summary

Environmental Effects of Hydrokinetic Turbines on Fish:

Desktop and Laboratory Flume Studies

A primary issue of concern of regulatory and resource agencies is how the operation of hydrokinetic turbines will affect local and migratory fish populations. In particular, two major concerns are the potential for fish to be killed or injured if they pass through one or more turbines and the potential for fish movements and migrations to be disrupted or blocked if fish are reluctant or unwilling to move past operating turbines. Fish that pass through hydrokinetic turbines may be injured or killed due to blade strike or damaging hydraulic shear and/or pressure conditions. This collection of three reports describes desktop and laboratory flume studies that provide information to support assessment of the potential for injury and mortality of fish that encounter hydrokinetic turbines of various designs installed in tidal and river environments. Behavioral responses to turbine exposure also are investigated to support assessment of the potential for disruptions to upstream and downstream movements of fish.

Accurate and precise determination of the probability of blade strike and injury, and of the behavior of fish as they encounter hydrokinetic turbines, was the primary goal of the studies. This goal is achieved by: (1) conducting an assessment of potential injury mechanisms using available data from studies with conventional hydro turbines; (2) developing theoretical models for predicting blade strike probabilities and mortality rates; and (3) performing flume testing with three turbine designs and several fish species and size groups in two laboratory flumes to estimate survival rates and document fish behavior. The strike probability and mortality models are verified using data collected during flume testing. These desktop analyses include an assessment of existing biocriteria for the safe passage of fish through conventional hydro turbines with respect to relevance and application to hydrokinetic devices, and development of theoretical models for predicting blade strike and mortality probabilities. Flume studies were conducted with three hydrokinetic turbine designs and several fish species/sizes to estimate turbine passage survival and injury rates and to determine behavior of fish as they approach and encounter operating turbines. Flume testing was conducted at Alden and CAFRL.

The project provides valuable data and information on behavior and injury and survival rates of fish passing hydrokinetic turbines. The behavioral data demonstrate that fish approaching turbines actively avoid passing through the blade sweep area. Estimates of survival and injury allow potential losses of fish to be determined for single or multiple unit installations. The information from these studies facilitates determination of potential impacts to fish populations and may diminish the need for expensive field studies, which often provide only marginal or incomplete data.

The project yielded three reports which this document comprises. The three constituent documents are:

- Fish Passage Through Turbines: Application of Conventional Hydropower Data to Hydrokinetic Technologies (EPRI Report ID 1024638)

- Evaluation of Fish Injury and Mortality Associated with Hydrokinetic Turbines (EPRI Report ID 1024569)
- Survival and Behavior of Juvenile Atlantic Salmon and Adult American Shad on Exposure to a Hydrokinetic Turbine (EPRI Report ID 1026904)

Fish Passage Through Turbines: Application of Conventional Hydropower Data to Hydrokinetic Technologies

This report reviews information on impacts of conventional hydropower turbines that can be used to evaluate potential impacts of hydrokinetic turbines on fish. The report discusses design and operational differences between conventional and hydrokinetic turbines as well as differences in the magnitude or potential for fish injury and mortality.

Fish passing through the blade sweep of a hydrokinetic turbine experience a much less harsh physical environment than do fish entrained through conventional hydro turbines. The design and operation of conventional turbines results in high flow velocities, abrupt changes in flow direction, relatively high runner rotational and blade speeds, rapid and significant changes in pressure, and the need for various structures throughout the turbine passageway that can be impacted by fish (e.g., walls, stay vanes, wicket gates, flow straighteners). Most, if not all, of these conditions do not occur or are not significant factors for hydrokinetic turbines. Furthermore, compared to conventional hydro turbines, hydrokinetic turbines typically produce relatively minor changes in shear, turbulence, and pressure levels from ambient conditions in the surrounding environment. Injuries and mortality from mechanical injuries will be less as well, mainly due to low rotational speeds and strike velocities, and an absence of structures that can lead to grinding or abrasion injuries. While information pertaining to conventional hydro turbines is useful for assessing the potential for adverse effects of passage through the swept area of hydrokinetic turbines, additional information is needed to rigorously assess the nature and magnitude of effects on individuals and populations, and to refine criteria for design of more fish-friendly hydrokinetic turbines.

Evaluation of Fish Injury and Mortality Associated with Hydrokinetic Turbines

Potential for fish to be injured or killed if they encounter hydrokinetic turbines is an issue of significant interest to resource and regulatory agencies. To address this issue, flume studies were conducted that exposed fish to two hydrokinetic turbine designs to determine injury and survival rates and to assess behavioral reactions and avoidance. Also, a theoretical model developed for predicting strike probability and mortality of fish passing through conventional hydro turbines was adapted for use with hydrokinetic turbines and applied to the two designs evaluated during flume studies. The flume tests were conducted with the Lucid spherical turbine (LST), a Darrieus-type (cross flow) turbine, and the Welka UPG, an axial flow propeller turbine. Survival and injury for selected species and size groups were estimated for each turbine operating at two approach velocities by releasing treatment fish directly upstream and control fish downstream of the operating units. Behavioral observations were recorded with underwater video cameras during survival tests and during separate trials where fish were released farther upstream to allow them greater opportunity to avoid passage through the blade sweep of each turbine. Survival rates for

rainbow trout tested with the LST were greater than 98% for both size groups and approach velocities evaluated.

Turbine passage survival rates for rainbow trout and largemouth bass tested with the Welka UPG were greater than 99% for both size groups and velocities evaluated. Injury rates of turbine-exposed fish were low for tests with both turbines and generally comparable to control fish. When adjusted for control data, descaling rates were also low (0.0 to 4.5%). Video observations of the LST demonstrated active avoidance of turbine passage by a large proportion fish despite being released about 25 cm upstream of the turbine blade sweep. Video observations from behavior trials indicated few if any fish pass through the turbines when released farther upstream. The theoretical predictions for the LST indicated that strike mortality would begin to occur at an ambient current velocity of about 1.7 m/s for fish with lengths greater than the thickness of the leading edge of the blades. As current velocities increase above 1.7 m/s, survival was predicted to decrease for fish passing through the LST, but generally remained high (greater than 90%) for fish less than 200 mm in length.

Strike mortality was not predicted to occur during passage through a Welka UPG turbine at ambient current velocities less than about 2.5 m/s. This research effort has resulted in a better understanding of the interactions between fish and hydrokinetic turbines for two general design types (vertical cross-flow and ducted axial flow). However, because the results generally are applicable to the presence of a single turbine, more analysis is needed to assess the potential for multiple units to lead to greater mortality rates or impacts on fish movements and migrations. Additionally, future research should focus on expanding the existing data by developing better estimates of encounter and avoidance probabilities.

Survival and Behavior of Juvenile Atlantic Salmon and Adult American Shad on Exposure to a Hydrokinetic Turbine

This report describes a series of experiments designed to measure the effect of exposure to a full-scale, vertical axis hydrokinetic turbine on downstream migrating juvenile Atlantic salmon (N=173) and upstream migrating adult American shad (N=208). Controlled studies were performed in a large-scale, open-channel flume, and all individuals approached the turbine under volitional control. No injuries were observed, and there was no measurable increase in mortality associated with turbine passage. Exposure to the turbine elicited behavioral responses from both species, however, with salmon passing primarily over the downrunning blades. Shad movement was impeded in the presence of the device, as indicated by fewer attempts of shorter duration and reduced distance of ascent up the flume. More work should be performed in both laboratory and field conditions to determine the extent to which these effects are likely to influence fish in riverine environments.

Contents

Page numbers below indicate sequential page number in this composite file. The report titles below are hyperlinked to the cover page of the corresponding report.

EPRI Report	Page
Fish Passage Through Turbines: Application of Conventional Hydropower Data to Hydrokinetic Technologies (EPRI Report ID 1024638)	9
Evaluation of Fish Injury and Mortality Associated with Hydrokinetic Turbines (EPRI Report ID 1024569)	65
Survival and Behavior of Juvenile Atlantic Salmon and Adult American Shad on Exposure to a Hydrokinetic Turbine (EPRI Report ID 1026904)	173

Fish Passage Through Turbines: Application of Conventional Hydropower Data to Hydrokinetic Technologies

2011 TECHNICAL REPORT

Fish Passage Through Turbines: Application of Conventional Hydropower Data to Hydrokinetic Technologies

EPRI Project Manager
P. Jacobson



3420 Hillview Avenue
Palo Alto, CA 94304-1338
USA

PO Box 10412
Palo Alto, CA 94303-0813
USA

800.313.3774
650.855.2121

askepri@epri.com

www.epri.com

1024638

Final Report, October 2011

DISCLAIMER OF WARRANTIES AND LIMITATION OF LIABILITIES

THIS DOCUMENT WAS PREPARED BY THE ORGANIZATION(S) NAMED BELOW AS AN ACCOUNT OF WORK SPONSORED OR COSPONSORED BY THE ELECTRIC POWER RESEARCH INSTITUTE, INC. (EPRI). NEITHER EPRI, ANY MEMBER OF EPRI, ANY COSPONSOR, THE ORGANIZATION(S) BELOW, NOR ANY PERSON ACTING ON BEHALF OF ANY OF THEM:

(A) MAKES ANY WARRANTY OR REPRESENTATION WHATSOEVER, EXPRESS OR IMPLIED, (I) WITH RESPECT TO THE USE OF ANY INFORMATION, APPARATUS, METHOD, PROCESS, OR SIMILAR ITEM DISCLOSED IN THIS DOCUMENT, INCLUDING MERCHANTABILITY AND FITNESS FOR A PARTICULAR PURPOSE, OR (II) THAT SUCH USE DOES NOT INFRINGE ON OR INTERFERE WITH PRIVATELY OWNED RIGHTS, INCLUDING ANY PARTY'S INTELLECTUAL PROPERTY, OR (III) THAT THIS DOCUMENT IS SUITABLE TO ANY PARTICULAR USER'S CIRCUMSTANCE; OR

(B) ASSUMES RESPONSIBILITY FOR ANY DAMAGES OR OTHER LIABILITY WHATSOEVER (INCLUDING ANY CONSEQUENTIAL DAMAGES, EVEN IF EPRI OR ANY EPRI REPRESENTATIVE HAS BEEN ADVISED OF THE POSSIBILITY OF SUCH DAMAGES) RESULTING FROM YOUR SELECTION OR USE OF THIS DOCUMENT OR ANY INFORMATION, APPARATUS, METHOD, PROCESS, OR SIMILAR ITEM DISCLOSED IN THIS DOCUMENT.

REFERENCE HEREIN TO ANY SPECIFIC COMMERCIAL PRODUCT, PROCESS, OR SERVICE BY ITS TRADE NAME, TRADEMARK, MANUFACTURER, OR OTHERWISE, DOES NOT NECESSARILY CONSTITUTE OR IMPLY ITS ENDORSEMENT, RECOMMENDATION, OR FAVORING BY EPRI.

THIS REPORT WAS PREPARED AS AN ACCOUNT OF WORK SPONSORED BY AN AGENCY OF THE UNITED STATES GOVERNMENT. NEITHER THE UNITED STATES GOVERNMENT NOR ANY AGENCY THEREOF, NOR ANY OF THEIR EMPLOYEES, MAKES ANY WARRANTY, EXPRESS OR IMPLIED, OR ASSUMES ANY LEGAL LIABILITY OR RESPONSIBILITY FOR THE ACCURACY, COMPLETENESS, OR USEFULNESS OF ANY INFORMATION, APPARATUS, PRODUCT, OR PROCESS DISCLOSED, OR REPRESENTS THAT ITS USE WOULD NOT INFRINGE PRIVATELY OWNED RIGHTS. REFERENCE HEREIN TO ANY SPECIFIC COMMERCIAL PRODUCT, PROCESS, OR SERVICE BY TRADE NAME, TRADEMARK, MANUFACTURER, OR OTHERWISE DOES NOT NECESSARILY CONSTITUTE OR IMPLY ITS ENDORSEMENT, RECOMMENDATION, OR FAVORING BY THE UNITED STATES GOVERNMENT OR ANY AGENCY THEREOF. THE VIEWS AND OPINIONS OF AUTHORS EXPRESSED HEREIN DO NOT NECESSARILY STATE OR REFLECT THOSE OF THE UNITED STATES GOVERNMENT OR ANY AGENCY THEREOF.

THE FOLLOWING ORGANIZATION, UNDER CONTRACT TO EPRI, PREPARED THIS REPORT:

Alden Research Laboratory, Inc.

NOTE

For further information about EPRI, call the EPRI Customer Assistance Center at 800.313.3774 or e-mail askepri@epri.com.

Electric Power Research Institute, EPRI, and TOGETHER...SHAPING THE FUTURE OF ELECTRICITY are registered service marks of the Electric Power Research Institute, Inc.

Copyright © 2011 Electric Power Research Institute, Inc. All rights reserved.

Acknowledgments

The following organization, under contract to the Electric Power Research Institute (EPRI), prepared this report:

Alden Research Laboratory, Inc.
30 Shrewsbury Street
Holden, MA 01520-1843

Principal Investigators
S. Amaral
G. Hecker
N. Pioppi

This report describes research sponsored by EPRI.

This material is based upon work supported by the Department of Energy Water Power Program under Award Number DE-EE0002659.

Constructive comments by Jocelyn Brown-Saracino and her colleagues, U.S. Department of Energy, and by Glenn Cada, Oak Ridge National Laboratory strengthened this report. We also thank Doug Dixon of EPRI for his leadership of this project during its formative stage.

This publication is a corporate document that should be cited in the literature in the following manner:

*Fish Passage Through Turbines:
Applicability of Conventional
Hydropower Data to Hydrokinetic
Technologies.*
EPRI, Palo Alto, CA: 2011.
1024638.

Report Summary

This report reviews information on impacts of conventional hydropower turbines that can be used to evaluate potential impacts of hydrokinetic turbines on fish. The report discusses design and operational differences between conventional and hydrokinetic turbines as well as differences in the magnitude or potential for fish injury and mortality. This report will be valuable to industry, resource agencies, non-governmental environmental organizations, and universities involved in research, management, and protection of aquatic ecosystems.

Background

Hydrokinetic generation is an emerging technology for producing electricity from flowing water. This form of generation differs from conventional and pumped storage hydropower generation in that it does not employ dams or other structures to impound water and create hydraulic head. Rather, hydrokinetic turbines are placed in natural, free-flowing water courses and man-made channels. Because hydrokinetic generation is a new form of power generation, relatively little information is available regarding potential impacts on fish individuals and populations. A substantial body of information exists, however, pertaining to the effects of turbine passage at conventional hydropower projects. Useful information can be obtained from the literature on turbine passage at conventional hydropower projects, despite important differences between conventional and hydrokinetic power generation.

Objectives and Approach

This report reviews existing information on injury mechanisms associated with fish passage through conventional hydro turbines and the relevance and applicability of this information to fish passage through hydrokinetic turbines. Available information includes probability of blade strike, blade strike survival rates, and criteria for shear levels and pressure regimes that can damage fish.

Results

Fish passing through the blade sweep of a hydrokinetic turbine experience a much less harsh physical environment than do fish entrained through conventional hydro turbines. The design and operation of conventional turbines results in high flow velocities,

abrupt changes in flow direction, relatively high runner rotational and blade speeds, rapid and significant changes in pressure, and the need for various structures throughout the turbine passageway that can be impacted by fish (e.g., walls, stay vanes, wicket gates, flow straighteners). Most, if not all, of these conditions do not occur or are not significant factors for hydrokinetic turbines. Furthermore, compared to conventional hydro turbines, hydrokinetic turbines typically produce relatively minor changes in shear, turbulence, and pressure levels from ambient conditions in the surrounding environment. Injuries and mortality from mechanical injuries will be less as well, mainly due to low rotational speeds and strike velocities, and an absence of structures that can lead to grinding or abrasion injuries. While information pertaining to conventional hydro turbines is useful for assessing the potential for adverse effects of passage through the swept area of hydrokinetic turbines, additional information is needed to rigorously assess the nature and magnitude of effects on individuals and populations, and to refine criteria for design of more fish-friendly hydrokinetic turbines.

EPRI Perspective

This report will provide hydrokinetic device and project developers, fisheries resource managers, and regulators with improved understanding of the potential for hydrokinetic turbines to adversely affect individual fish and fish populations. The information contained in this report can also be used by researchers and potential research funders to identify areas for future, productive research.

Keywords

Fish
Hydrokinetic
Hydropower

Table of Contents

Section 1: Introduction	1-1
Section 2: Review and Application of Conventional Hydropower Data to Hydrokinetic Turbines	2-1
Shear and Turbulence.....	2-2
Review of Shear Studies	2-3
Review of Turbulence Studies	2-7
Potential for Shear and Turbulence to Injure Fish Passing Through Hydrokinetic Turbines	2-8
Shear and Turbulence Bio-Criteria for Hydrokinetic Turbines	2-9
Pressure and Cavitation	2-9
Review of Pressure Studies	2-10
Review of Cavitation Studies	2-14
Potential for Pressure and Cavitation to Injure Fish Passing Through Hydrokinetic Turbines	2-16
Pressure and Cavitation Bio-Criteria for Hydrokinetic Turbines	2-16
Mechanical (Strike and Grinding)	2-17
Review of Blade Strike Studies.....	2-17
Review of Grinding and Abrasion Studies	2-21
Potential for Mechanical Injury to Fish Passing Through Hydrokinetic Turbines.....	2-22
Mechanical Bio-Criteria for Hydrokinetic Turbines	2-22
Section 3: Summary and Conclusions	3-1
Section 4: Literature Cited.....	4-1

List of Figures

- Figure 2-1 Fish mortality as a function of the ratio of exposure pressure to acclimation pressure2-11
- Figure 2-2 Pressure exposure simulation of turbine passage for surface- and depth-acclimated fish.....2-13
- Figure 2-3 Blade strike survival rates of rainbow trout tested at various fish length to leading edge thickness ratios (L/t) over a range of strike velocities.....2-21

List of Tables

Table 3-1 Comparison of design and operational features associated with conventional hydro and hydrokinetic turbines.....	3-2
Table 3-2 Recommended bio-criteria for hydrokinetic turbines.....	3-4



Section 1: Introduction

A lack of information on potential environmental impacts and the subsequent need to gather extensive field data have hindered project developers from obtaining necessary permits for the installation of pilot and full-scale hydrokinetic projects in a timely and cost-effective manner. Environmental issues that appear to be of greatest importance to state and federal resources agencies typically include issues associated with potential impacts to fish populations, including habitat alteration, disruptions in migrations and movements, and injury and mortality to fish that encounter turbines. In particular, there is considerable concern for fish and other aquatic organisms to interact with hydrokinetic turbines in a manner that could lead to alterations in normal behavioral patterns (e.g., migrations, spawning, feeding) and/or significant levels of injury and mortality (i.e., injuries resulting from entrainment through the water volume swept by the blades of one or more turbines). To develop information and data that can be used to assess the probability of such impacts occurring for any given project, the Electric Power Research Institute was awarded a grant by the U.S. Department of Energy (DOE) to complete the following studies:

- Review of existing information on injury mechanisms associated with fish passage through conventional hydro turbines and the relevance and applicability of this information to fish passage through hydrokinetic turbines.
- Development of theoretical models for the probability of blade strike and mortality for various hydrokinetic turbine designs.
- Flume testing with three turbine designs and several species and size classes of fish to estimate injury and survival rates and describe fish behavior in the vicinity of operating turbines.

EPRI contracted Alden Research Laboratory, Inc. (Alden) to conduct the first two efforts (i.e., desktop studies) and Alden and the U.S. Geological Survey's Conte Anadromous Fish Research Laboratory (CAFRL) to conduct flume testing. This report presents the results of the review of conventional hydropower data on fish passage through turbines and its relevance to hydrokinetic technologies. There are separate reports for flume testing and theoretical modeling at Alden (EPRI 2011a) and flume testing at the CAFRL (EPRI 2011b). The primary goal of the EPRI studies is to provide developers and resource and regulatory agencies with data and information that will lead to a better understanding of the potential impacts of hydrokinetic turbines on local and migratory fish populations. Achieving this goal will assist with licensing of proposed projects in the U.S. where hydrokinetic turbines have been or are being considered for installation.

Impacts to aquatic organisms by hydrokinetic turbines will depend primarily on turbine design and operational parameters and the environment in which the turbines are deployed (e.g., river, tidal, or ocean) and the ability of aquatic organisms to detect and subsequently avoid these devices. Potential direct impacts include fish injury and mortality due to blade strike and/or hydraulic conditions that can damage or disorient fish (Coutant and Čada 2005; EPRI 2006; Čada et al. 2007; DOE 2009). Indirect impacts are related to disruptions in volitional or natural movements and migrations or access to feeding, spawning, and nursery habitats in the vicinity of turbine installations (DOE 2009). The size and number of turbines installed may influence the magnitude of direct and indirect impacts. The potential for injury and mortality of fish that pass through operating hydrokinetic turbines is an obvious concern, particularly if installations are located in rivers with diadromous fish populations (i.e., species that undergo obligatory upstream and downstream migrations that occur during specific times of the year). The potential for fish injury and mortality may also be an important issue for tidal and ocean turbines located in biologically productive areas (i.e., areas where the probability of large numbers of fish encountering or passing through turbines is high).

A large amount of information and data related to fish passing through conventional hydro turbines has been compiled in recent years, mainly through the U.S. Department of Energy's (DOE) former Advanced Hydro Turbine Systems Program (Čada 2001; <http://hydropower.inel.gov/turbines>). Various mechanisms that lead to turbine passage injury and mortality have been extensively evaluated in the lab and field and some of these data should be applicable to fish passage through or near hydrokinetic turbines. Available information includes probability of blade strike, blade strike survival rates, and criteria for shear levels and pressure regimes that can damage fish. Previous assessments that have examined potential environmental impacts of hydrokinetic turbines have recognized that information and data from studies of fish passing through conventional hydro turbines may be useful in determining the risk of injury and mortality for fish encountering hydrokinetic turbines (Coutant and Čada 2005; EPRI 2006; Čada et al. 2007; DOE 2009). These assessments have generally concluded that fish passing through hydrokinetic turbines should suffer less damage, if any, because known injury mechanisms typically are not as severe or as prevalent compared to conventional hydropower turbines. However, despite what appear to be logical conclusions, previous reviews of the existing data have not been sufficient or rigorous enough to alleviate many concerns regarding the ability of fish to safely interact with hydrokinetic turbines.

Although the available data for conventional hydro turbines may be applicable to hydrokinetic turbines, the following operational differences should be noted:

- Hydrokinetic devices operate in an open environment with water flowing both through and around the devices, whereas conventional hydro turbines incorporate an intake and/or penstock that conveys all the flow through the runner. The open environment around hydrokinetic turbines offers the opportunity for aquatic organisms to detect and avoid the devices.

- Hydrokinetic devices operate with essentially no head differential (other than that created by a device itself), which provides low shear levels and small pressure changes from upstream to downstream. Conversely, conventional hydro turbines typically operate under head differentials of anywhere from 10 ft to 1,000 ft, resulting in potentially high levels of shear and considerable pressure differences and pressure change rates.
- Hydrokinetic turbines generally operate at considerably lower rotational speeds and blade velocities, which will contribute to lower probabilities of blade strike and mortality from strike.

The goal of the review of turbine passage studies associated with conventional hydropower was to synthesize the available information in order to draw inferences as to how known injury mechanisms may or may not lead to injury and mortality of fish interacting with hydrokinetic devices. The information gathered has been categorized by injury mechanism type (e.g., shear and turbulence, pressure, and mechanical) and is discussed in terms of design and operational differences between conventional hydro and hydrokinetic turbines, as well as differences in the magnitude or potential for fish injury and mortality.



Section 2: Review and Application of Conventional Hydropower Data to Hydrokinetic Turbines

An extensive amount of research has been conducted during the past 60 years in attempts to determine injury and survival rates for fish passing through conventional hydro turbines and to identify and quantify injury mechanisms (e.g., flow shear and turbulence, pressure changes, grinding and abrasion in gaps, blade strike, and cavitation). Much of this research has been conducted with anadromous salmonids to address smolt losses at hydro projects in the Pacific Northwest. Numerous studies were also conducted at hydro projects throughout the Midwest and Northeast in the 1990's to estimate turbine passage survival for diadromous and riverine fishes. These studies were conducted as part of FERC relicensing efforts and were used to assess the need for downstream fish passage and protection facilities. Also in the 1990's, the DOE established the Advanced Hydro Turbine Systems Program (AHTS) in an attempt to develop improved turbine technologies that reduced damage to entrained fish. In addition to the development of two "fish-friendly" turbine designs for conventional hydropower projects (the Alden turbine and the Minimum Gap Runner Kaplan), this program sponsored many studies that examined fish injury mechanisms and produced data that have formed the basis for the development of bio-criteria for current and future advancements in turbine design and operation. More recent studies funded by the Electric Power Research Institute (EPRI) have continued to investigate means to increase turbine passage survival. This research has included blade strike experiments that have provided data and guidelines for reducing fish mortality by re-designing the leading edge of turbine blades.

The primary injury mechanisms for fish passing through conventional hydro turbines that have been identified and investigated during previous research efforts are:

- High shear and turbulence levels
- Rapid and excessive pressure reductions
- Cavitation
- Grinding and abrasion between moving and stationary components
- Leading edge blade strike

Data and information that have been gathered on these injury mechanisms have been used in the development of advanced conventional hydro turbine designs that cause less damage to fish (Čada 2001). This information should have considerable applicability to assessment of the potential effects of hydrokinetic turbines on fish. For example, the effects of operational parameters (e.g., runner speed) on blade strike probability and mortality have been used to assess damage to fish passing through conventional hydro turbines (Ploskey and Carlson 2004; Deng et al. 2005; Hecker and Allen 2005) and, in a similar manner, can be adapted to assess direct strike mortality rates associated with hydrokinetic turbines. Also, shear and pressure bio-criteria can be compared to theoretical and numerical model data for hydrokinetic turbines to determine if thresholds for damage to fish are exceeded, and to determine in what areas of the turbine this damage may occur. A detailed review of previous research on the various injury mechanisms associated with fish passage through conventional hydro turbines and its relevance to hydrokinetic technologies is provided below.

Shear and Turbulence

Shear and turbulence are hydraulic conditions that occur with flow of water through intakes, turbines, and draft tubes. When exposed to shear and turbulence, a fish experiences differential forces across its body (Killgore et al. 2001) which can cause rotation and deformation and lead to injury and mortality (Morgan et al. 1976). The intensity and amount of shear and turbulence encountered by a fish during turbine passage will depend on project design and operation. Shear and turbulence have been identified as potential sources of injury and mortality for fish passing through hydroelectric turbines (Solomon 1988; Čada et al. 1997). Both parameters describe changes in water velocity over a specified distance (e.g., the length of a fish). Shear describes the change in water velocity with respect to distance that results from adjacent water masses moving with different velocities. The impact caused by shear, or shear stress, is expressed as a force per unit area acting upon a surface. Conditions that produce high levels of shear exist throughout conventional hydroelectric turbines, but fish typically encounter them when passing between flow masses of differing velocities or near solid surfaces. Shear forces are expected to be greatest along solid boundaries or at the leading edge of turbine blades (USACE 1995, Čada et al. 1997).

Turbulence occurs when fluid masses within a moving water body make small and intense changes in direction other than that of the bulk flow direction (Vogel 1981) and can also result from the breakdown of shear zones (Turnpenny et al. 1992). Due to high velocities and boundary effects of structures, flow passing through a turbine can be highly turbulent (Neitzel et al. 2000). The effect of turbulence on fish depends on the turbulence scale (size) and intensity (magnitude of velocity variations compared to the average flow velocity). Small-scale turbulence can be found throughout a conventional turbine passageway, particularly in the wake of the runner blades (Turnpenny et al. 2000), whereas large-scale turbulence tends to be highest within the turbine draft tube (Čada et al. 1997). Small-scale turbulence has been found to result in body compression and distortion in fish; large-scale turbulence often creates vortices which spin fish and cause disorientation (Čada et al. 1997).

More detailed descriptions of the physical characteristic that define hydraulic shear and turbulence and their occurrence at hydro projects are provided by Čada et al. (1997) and Odeh et al. (2002).

Review of Shear Studies

Studies conducted to assess the effects of shear on turbine-passed fish have focused on determining thresholds at which injury and mortality are likely to occur. Studies have also been conducted to quantify shear levels to which fish may be exposed when passing through turbines. However, the ability to correlate injury and mortality with shear levels experienced by individual fish that are collected after turbine passage has been problematic (Deng et al. 2005). Also, this type of field assessment can be complicated by the presence of other mechanisms that can result in similar injuries (e.g., blade strike).

Velocities and magnitudes of shear stress experienced by fish passing through turbines are expected to be greater than those experienced by fish in their natural environments. Measurements of velocity within a turbine have been reported to vary from zero near solid boundaries to as high as 120 ft/s away from boundary effects, with the magnitude of change across shear zones estimated to be approximately 30/s (USACE 1995). Early estimates of shear stress values for bulb turbine draft tubes ranged from 500 - 5,400 N/m², with stress levels below 1,000 N/m² in over 90% of the passage zone (McEwen and Scobie 1992).

Based on the estimates by McEwen and Scobie (1992), Turnpenny et al. (1992) exposed salmonids to a high-velocity water jet in a static water tank that created shear stress values of a similar magnitude. Results from post-exposure evaluations showed no injuries or mortalities to fish from shear stress values at or below 774 N/m². Results also suggested that fish orientation at initial exposure influenced injury rates and that mortality was proportional to jet velocity. Common injuries observed in fish exposed to higher values included eye damage or loss, torn gill covers, loss of mucous layer leading to osmotic imbalance, and deformation. In a review of this and other studies using the same experimental design, Čada et al. (1997) concluded that the extent of damage to fish from shear stress varied by species, size, and life-stage. Reviewers also pointed out that the experimental design restricted testing to small-scale effects; the demonstration of larger-scale effects would require additional study (Čada et al. 1997).

Although these studies succeeded in creating damaging shear effects, the exact levels of shear to which fish were exposed were not fully quantified in either study. In addition, fish experienced a different shear regime depending on their distance from the jet nozzle. To address these issues, subsequent studies have employed computer modeling techniques to predict shear forces throughout a turbine pathway, including shear surrounding runner blades and other structural components (e.g., wicket gates and stay vanes). In a follow-up to their previous research, Turnpenny et al. (2000) applied Computational Fluid Dynamic (CFD) techniques to identify the risk of injury from shear effects in small low-head (< 30 m) Francis and Kaplan turbines. The CFD model indicated that shear stress levels were of minor importance in both turbine types based on low

probabilities of occurrence. Combining the computer modeling data with a modified formula for estimating injury due to blade strike, investigators predicted that less than 2% of salmonids passing through low-head turbines would suffer potentially fatal injuries from shear stress (Turnpenny et al. 2000). Field tests performed at representative sites were able to validate these predictions, although investigators based their comparisons on the assumption that observed eye injuries were the result of shear and not another type of injury mechanism (e.g., blade strike).

More recent studies have evaluated the responses and/or tolerance levels of fish to shear stresses associated with hydro turbines for the purpose of establishing biological criteria that will aid in the design of more advanced fish-friendly turbines. In a comprehensive study performed at the Pacific Northwest National Laboratory (PNNL), investigators modeled and quantified the shear environment within a turbine passage using CFD techniques and then designed a test facility based on their model to assess the biological responses of several salmonid species and American shad to comparable levels of shear (Neitzel et al. 2000, 2004; Guensch et al. 2002). During the biological tests, juvenile salmonids (Chinook, rainbow trout, steelhead) and American shad were exposed to a shear environment at the edge of a high-velocity water jet, with the interactions recorded by a high-speed video system. Experimental conditions were selected to address the assumptions that the magnitude of shear effects would depend on the relative velocity of fish to fluid, the shape of the fish, and the orientation of the fish to flow. Test fish were subjected to strain (shear) rates from 168 to 1,185/s (corresponding to velocity differences of about 3 to 21 m/s over a distance of about 1.8 cm).

Neitzel et al. (2004) reported that injuries classified as “significant major” were not observed for any of the species tested at or below a strain rate of 517/s (velocity of 9.1 m/s over a distance of 1.8 cm). The study results indicated American shad were the most susceptible to shear-related injuries, whereas steelhead and rainbow trout were least susceptible. Shear-related injuries also varied based on initial fish orientation, with fish released headfirst suffering more damage than those released tail first. (Note: The design of the experimental apparatus was such that fish moving headfirst down the introduction tube were struck from behind by the jet. Thus, a “headfirst” release resulted in shear forces that opened the operculum and lifted scales in a direction from the back of the fish forward toward the head.) Typical headfirst injuries included torn operculi, injured gill arches, and missing eyes. Neitzel et al. (2000) concluded that their results, as well as those from other studies, supported the general conclusion that single exposures to shear strain rates of 850/s (15 m/s over 1.8 cm) and higher would be harmful to juvenile fish (Neitzel et al. 2000) and that injury or mortality to the tested fish is unlikely to occur at strain rates less than about 500/s.

Guensch et al. (2002) and Deng et al. (2005) presented the results for an analysis of the high-speed video from the above study that was taken during the exposure of each fish to the high-velocity jet (Neitzel et al. 2000), concentrating primarily on tests conducted with Chinook salmon. Using a quantitative approach to the analysis, values of specific parameters (fish velocity, acceleration, jerk, impulse,

and force) were calculated from observations of the release and injury mechanisms recorded. Most injuries were observed to occur upon the initial contact of a fish with the jet and not after a fish fully entered the flow. At strain rates of 688 and 852/s, which correspond to velocity gradients of 12.5 and 15.2 m/s over 1.8 cm, damage to the operculum was the most frequently observed injury. Injuries to the eye, isthmus, and the gill arches were equally common at the highest strain rate (1,185/s) and corresponding velocity gradient (21.3 m/s over a distance of 1.8 cm). Underyearling (Age 0) fish appeared less susceptible to injury than larger yearling (Age 0) fish, especially at lower jet velocities, but the smaller fish were more susceptible to disorientation following shear exposure. In general, Guensch et al. (2002) found that all parameters examined from a fish's bulk motion (velocity, jerk, and force) were positively correlated to injury levels.

Neitzel et al. (2004) used a logistic regression model to further explain the effect of strain rate on injury or mortality for various test groups. This approach was used to estimate strain rates at which 10% of a population suffered injury and/or mortality (i.e., LC-10). Calculations of LC-10 values demonstrated that juvenile salmonids sustained minor injury when exposed to a shear zone having a strain rate equal to or less than about 500/s. Also, the LC-10 values were lower for fish entering the shear zone head first compared to entering tail first. Overall, authors of these PNNL studies asserted that their results succeeded in defining the relationship between fish injury and shear forces (strain rates) present at hydroelectric projects (i.e., associated with turbines, spillways, and gates) and provided useful bio-criteria for improving fish passage and survival with future turbine designs.

As part of the Advanced Hydropower Turbine Systems Program sponsored by the U.S. Department of Energy (DOE), Alden Research Laboratory, Inc. (Alden) and Concepts NREC conducted a multi-phase research program to design, construct, and test a new turbine to minimize fish injury at hydropower projects (Cook et al. 2003). Based on an evaluation of previous turbine mortality studies, Alden developed biological criteria to aid in their turbine design, including the maximum allowable shear (Cook et al. 1997). The initial criterion used for minimizing shear-related injuries was a maximum strain rate of 180/s. However, this criterion was later modified based on the research discussed above and CFD modeling that was performed to determine if biological criteria for eliminating injuries associated with shear (as well as turbulence and pressure) were being met (Cook et al. 2003; Lin et al. 2004). Although the CFD simulations indicated the presence of strain rates greater than the subsequently established design criterion (i.e., a maximum strain rate of 500/s), these zones were relatively small and considered unlikely to cause significant injury or mortality to turbine-passed fish. Biological testing conducted with a pilot-scale Alden turbine and six species of fish indicated that observed injuries and mortalities were likely due to blade strike and not other mechanisms (i.e., damaging levels of flow shear, turbulence, and pressure) (Cook et al. 2003).

Building upon a growing body of work, investigators began to take a more comprehensive look at the effects of shear on fish within hydroelectric turbines. Using a multi-discipline approach, Čada et al. (2006) combined measurements of hydraulic conditions inside turbines, results from laboratory testing of associated shear stresses on fish, CFD modeling, and field evaluations of injury and mortality in an attempt to define and mitigate the impact of shear on turbine-passed fish at a dam on the Columbia River. The authors of this study used the previously determined minimum strain rate (517/s; Neitzel et al. 2004) at which injuries became more prevalent for juvenile salmonids to calculate the maximum shear force value (1.6 kPa). Using this value as an injury/mortality threshold, CFD modeling was performed under multiple sets of conditions existing within a Kaplan turbine at the Wanapum Dam on the Columbia River. After verifying the CFD model's accuracy by using velocity measurements taken during the aforementioned PNNL lab study (Neitzel et al. 2000, 2004), Čada et al. (2006) estimated that areas of potentially lethal shear stress within the turbine existed in areas in or near the stay vanes and wicket gates, runner, and draft tube. However, areas with potentially damaging shear levels were shown to comprise less than 2% of the volume of flow through the turbine under typical operating conditions. Using the assumption that mortality from shear would be proportional to the flow-weighted volumes estimated by CFD, the authors concluded that less than 0.6% of turbine-passed fish at Wanapum would suffer mortality due to shear stresses associated with the turbine flow rates at which field tests were conducted. While mortality rates estimated from a field study at Wanapum (NAI et al. 2006) were higher than those predicted from the shear stress data, the authors provided several reasons for these differences, including the likelihood that other injury mechanisms (strike, pressure, cavitation, etc.) may have contributed to the higher values of the empirical data and that the effects of each injury mechanism change with turbine flow rate.

An advanced hydropower turbine (AHT) designed to improve the survival of turbine-passed fish was installed at Unit 8 of the Wanapum Dam and several studies were conducted to compare its biological performance to that of the project's existing Kaplan units. The AHT was designed to reduce velocity gradients (shear) and flow recirculation using new features such as shaped stay vanes and a modified draft tube. Dauble et al. (2007) summarized the results of studies that were performed for the Wanapum turbines to determine if fish survival associated with the AHT design would meet performance goals. These studies included evaluations of mechanical, pressure, and shear and turbulence injury mechanisms. To examine the various forces experienced by fish passing through each turbine design, an autonomous sensor device (the Sensor Fish) was released into each turbine intake concurrently with tagged live fish. Pressure and acceleration measurements collected by the sensor fish were analyzed in tandem with CFD simulations to predict the location, frequency, and severity of shear exposure events during passage. The results of this analysis indicated there were fewer severe shear events for the AHT (1.1%) than the conventional turbines (3.4%) at Wanapum. Sensor fish data were also correlated with lab observations of shear-type injury to estimate shear injury rates for each turbine.

Overall, predicted probabilities of major shear injury were 3.1% for the AHT and 4.4% for the conventional turbine, whereas field observations with tagged fish of injuries believed to be caused by shear stresses were 1.1% for the AHT and 0.9% for the conventional Kaplan unit.

In addition to studies that have investigated shear-related injury associated with hydro turbine passage, several studies have examined shear effects on ichthyoplankton with respect to other human-induced impacts (e.g., entrainment through cooling water intakes and barge propellers and wash). Morgan et al. (1976) examined the effects of shear on fish eggs and larvae using an experimental apparatus that included two concentric plexiglass cylinders (20.3 and 30.5 cm diameter) permanently fixed to a plexiglass base with a third rotating cylinder (25.4 cm diameter) placed between them. The movement of the middle cylinder was used to create shear fields in the inner and outer chambers of the apparatus. White perch and striped bass larvae and fertilized eggs were introduced into the test chamber to evaluate the effects of shear on each species and life stage. Exposures to shear lasted from 1 to 20 minutes. The apparatus was operated at a speed (rpm) that produced shear levels of 76 to 404 dynes/cm². Mortality consisted of disruption of the yolk-protein material or total disintegration for eggs and lack of mobility or acute tissue destruction for larvae. The results were reported as shear rates that produced 50% mortality of test specimens within various time intervals. This level of mortality occurred at shear rates of 415 to 785 dynes/cm² for one minute of exposure and 125 to 300 dynes/cm² after four minutes of exposure. The lowest thresholds for 50% mortality were experienced by white perch larvae and the highest by striped bass larvae. Striped bass eggs were also shown to be less prone to injury and mortality than white perch eggs.

Killgore et al. (2001) evaluated survival of early life stages of fish after entrainment through a scale-model towboat propeller in a circulating water channel. Shovelnose sturgeon larvae, lake sturgeon larvae, paddlefish eggs and larvae, and blue sucker larvae were injected 38 cm upstream of the 46 cm-diameter propeller. They were then collected in downstream nets and observed for immediate and delayed mortality (up to 180 minutes after entrainment). The propeller was operated at several different speeds to achieve shear stresses of 634, 1613, 3058, and 4743 dynes/cm². Mortalities observed under these conditions were then compared to control mortality without the propeller activated. At shear forces of 4743 dynes/cm², observed mortality was as high as 86.0% and was significantly greater than control mortality for most species. However, mortality rates were not significantly different from the control mortality at shear stresses below 1613 dynes/cm².

Review of Turbulence Studies

The effects of turbulence on turbine-passed fish have been less studied and are more difficult to assess than other injury mechanisms associated with turbine passage. Turbulence is characterized by fluctuations in velocity magnitude and direction associated with moving water. Because shear forces are present in turbulent flow, it is often difficult to differentiate the effects of shear and turbulence. Shear stress in turbulent flows often causes eddies, while turbulent

flows result in shear forces and shear stress from the interaction of water moving at different velocities and in different directions (Odeh et al. 2002). Turbulence can be quantified in terms of shear stress, but is also a function of intensity and scale. In general, the physical effects of shear and turbulence on an organism are probably similar. Injuries associated with turbulence may be less severe and less likely to lead to direct mortality; however, turbulence could be a primary source of disorientation, particularly for fish exiting draft tubes, leading to indirect mortality (i.e., increased susceptibility to predation) (Čada et al. 1997).

In an effort to quantify ichthyoplankton mortality rates associated with turbulence created by barges, Killgore et al. (1987) investigated the survival of paddlefish yolk-sac larvae exposed to turbulence of different frequencies and intensities. The results of this study indicated that the intensity of turbulence, expressed in terms of pressure and velocity, was more harmful to paddlefish larvae than the frequency of exposure. Low turbulence levels (1,770-1,900 dynes/cm²; 22-23 cm/s) resulted in short-term mortality rates equal to or less than 13%. High turbulence levels (6,220-6,420 dynes/cm²; 57-59 cm/s) produced short-term mortality rates equal to or greater than 80%.

Potential for Shear and Turbulence to Injure Fish Passing Through Hydrokinetic Turbines

Based on the review of available information and data, shear and turbulence levels that are damaging to fish are unlikely to occur with most hydrokinetic turbines. At conventional hydro projects, high levels of shear typically occur near boundaries, where there are changes in flow paths, such as along solid surfaces (walls, turbine blades, wicket gates), and in narrow passages or gaps between turbine components (USACE 1995, Čada et al. 1997). Intense turbulence is typically associated with draft tubes and small regions in the runner. Because hydrokinetic turbines generally lack structures leading to and from the rotors or blades (e.g., stay vanes, wicket gates, draft tubes) where high levels of shear and turbulence occur, and they operate with much lower velocities with little change in flow direction, the potential for injury due to excessive shear and turbulence will be negligible or absent for many hydrokinetic turbine designs. As with conventional hydro turbines, damaging shear levels may occur in close proximity to hydrokinetic turbine blades or rotors, but such occurrences probably will be constrained to regions that are small relative to the available passage space through a blade sweep. Although the volume of areas with damaging shear varies with turbine design and operation, there is evidence that less than 2% of flow paths through advanced conventional turbines have shear levels sufficiently high to cause damage to fish (Čada et al. 2006; Cook et al. 2003; Lin et al. 2004). In support of these conclusions, a recent report describing potential environmental impacts of marine and hydrokinetic technologies (DOE 2009) did not identify shear or turbulence as potential mechanisms for fish injury.

Research on shear forces capable of damaging fish suggest that shear strain rates less than about 500/s will not result in injury or mortality. This criterion is based primarily on data from tests with juvenile salmonids and American shad, but is likely to be protective of many other species as well. Computer modeling can be

utilized to determine the location and extent of regions of high strain rates, but evidence from models conducted with conventional turbines demonstrates that damaging shear is unlikely to impact fish passing through hydrokinetic turbines (Cook et al. 2003; Čada et al. 2006; Dauble et al. 2007). Also, the absence of confined flow paths downstream of hydrokinetic turbines (i.e., no draft tubes) and relatively uniform flow direction from upstream to downstream should not produce turbulence of a scale and magnitude that could injure fish. Small-scale turbulence may occur in the vicinity of blades or rotors and other turbine components, but is unlikely to occupy a sufficient volume relative to the entire passage volume through a turbine to cause damage to fish at a rate that would lead to a noticeable or measurable impact. Also, velocities are considerably higher in conventional turbines because they operate under static head and the flow path from the intake through the turbine becomes constricted. Conversely, velocities approaching and passing through hydrokinetic turbines are the same or similar in magnitude to ambient currents.

Shear and Turbulence Bio-Criteria for Hydrokinetic Turbines

Despite the unlikelihood that damaging levels of shear and turbulence will occur with hydrokinetic turbines, consideration of biological design criteria during pre-development analyses of performance can still ensure minimal impacts to aquatic organisms. Based on the existing data and information, the potential for shear-related injury and mortality could be eliminated if hydrokinetic turbines are designed and operated so as to minimize the occurrence of strain rates greater than 500/s. Laboratory studies have identified exposure strain rates in the range of 495/s up to 833/s as the minimum strain rate at which fish begin to exhibit injuries and mortality, depending on species and life stage (Turnpenny et al. 1992, Neitzel 2000; Neitzel et al. 2004, Deng et al. 2005), although values may be lower for fish larvae and eggs (Morgan et al. 1976, Killgore et al. 1987, Killgore et al. 2001). In addition, studies comparing CFD modeling data with empirical data to identify areas of high shear and turbulence forces within turbines have found that when the frequency and/or volume of areas with damaging strain rates are minimized, fish injury and mortality rates are low (Cook et al. 2003, Čada et al. 2006). Disorientation and increased stress are also likely to be reduced due to the more “fish-friendly” hydraulic conditions associated with hydrokinetic turbines, which will lead to less potential for indirect mortality (e.g., predation, disease) as well.

Pressure and Cavitation

Low pressure, rapid change in pressure, and cavitation have all been identified as mechanisms that can lead to injury and mortality of fish passing through conventional hydro turbines (Solomon 1988; Turnpenny 2000; Čada et al. 1997). The potential for pressure-related injury and mortality depends on the magnitude of pressure reduction and how rapidly it occurs, how quickly fish can adjust to changing pressure conditions, and the acclimation pressure of fish when they enter a turbine intake. Cavitation (the formation of water vapor bubbles that collapse suddenly and cause high pressure spikes) can also lead to injury and mortality. However, cavitation is often limited to small regions around runner blades when

turbines are operated off their design point. The potential for damaging low pressure regimes and cavitation to occur with hydrokinetic turbines is low because hydrokinetic turbines are not operated under the higher heads associated with conventional turbines. Similar to conventional turbines, hydrokinetic turbines are designed and operated in a manner that minimizes cavitation.

Review of Pressure Studies

Rapid reductions in pressure are considered a potential injury mechanism for fish passing through conventional hydro turbines and are represented by the force per unit area acting upon a specific point (Čada et al. 1997). Pressures associated with conventional hydro turbines have been measured from a high of 460 kPa to a low of 2 kPa (Montgomery Watson 1995). Following entrainment into a turbine intake, a surface-oriented fish is subjected to an increase in pressure upstream of the runner, with the duration varying from seconds to minutes depending on the resistance of the fish to passage (Dadswell et al. 1986, Abernethy et al. 2001). When passing through the runner into the draft tube, fish experience a rapid decrease in pressure, often in a matter of seconds or less, that often falls below atmospheric levels (Čada 1990, Abernethy et al. 2001). Upon exiting a draft tube, fish are exposed to near atmospheric pressure as they surface in the tailrace (Čada 1990, Abernethy et al. 2001).

During passage through a conventional turbine, fish encounter a wide range of pressures and may have some control (both temporally and spatially) over their exposure and have the ability to make quick physiological adjustments. The capacity of fish to adjust to changes in pressure is primarily dependent on their type of buoyancy control, including whether they have a swim bladder (also referred to as an air or gas bladder). Only ray-finned fish have swim bladders, which includes all species commonly entrained at hydro projects in North America. Species with swim bladders are classified as either physostomous or physoclistous based on how they regulate swim bladder volume. Physostomous fish, such as salmon and trout species, have a pneumatic duct connecting the swim bladder and esophagus which allows for rapid intake and venting of gas. Physoclistous fish, such as freshwater bass and sunfish species, lack a pneumatic duct, resulting in slower adjustments to bladder volume via gas diffusion through the swim bladder wall. As a result, physoclistous fish have limited ability to compensate for the rapid pressure changes that typically occur during turbine passage compared to physostomous fish and are more susceptible to pressure-induced damage. In addition to the means of controlling swim bladder volume, acclimation pressure of fish prior to entering a hydro intake and passing through a turbine may influence the potential for pressure-related injury or formation of embolisms.

Initial laboratory evaluations demonstrated species-specific responses by exposing fish to various pressures and rates of pressure change under laboratory conditions. Salmonids (physostomous) exposed to gradual and rapid increases in pressure up to as high as 2,064 kPa followed by decompression to atmospheric pressures showed little or no mortality (Harvey 1963, Rowley 1955, Foye and Scott 1965). Conversely, salmonids exposed to low pressures showed higher mortality rates

than controls at pressures below 84.6 kPa (Harvey 1963). In addition, increases in decompression rates resulted in higher mortalities for both physostomous and physoclistous fish (Tsvetkov et al. 1972). Turnpenny et al. (1992) tested marine fishes under pressure scenarios that mimicked passage through a low-head turbine at a tidal barrage and found that physostomous fish showed much less external damage and a higher tolerance to the scenarios tested than physoclistous fish. When laboratory tests examined pre-exposure acclimation pressure as a variable, fish mortality was shown to be directly related to the magnitude of depressurization (Feathers and Knable 1983).

In a comprehensive review of these studies, Čada et al. (1997) concluded that pressure increases similar to those experienced in hydro turbines (i.e., as fish move deeper when approaching a turbine) were unlikely to cause injury or mortality to fish. However, it was concluded that exposures to sub-atmospheric pressures within turbines were more damaging, particularly to physoclistous fish. Specifically, the highest mortalities were observed when the rate of pressure decrease and the difference between the fish's acclimation and exposure pressure were greatest (Čada et al. 1997). To demonstrate this, Čada et al. (1997) compared mortality rates to the ratio of exposure and acclimation pressure reported in the studies reviewed (see Figure 2-1). The results of this comparison suggested that pressure-related mortality was likely to be minimized when minimum exposure pressures remained above 60% of acclimation pressure. Although this was a more conservative estimate compared to a criterion of 30% previously suggested by ARL (1996), this lower minimum value was based on data for salmonids (physostomous fish; USACE 1991) and would be less protective for physoclistous fish.

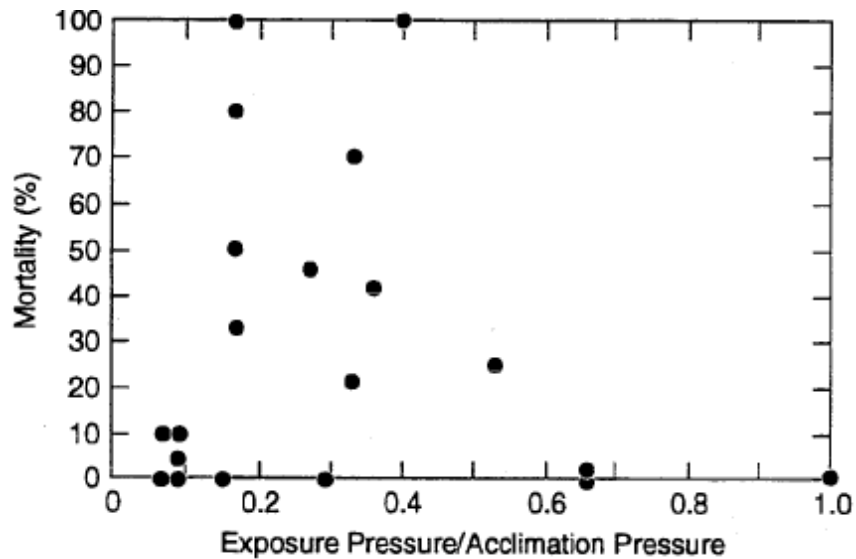

Figure 2-1
 Fish mortality as a function of the ratio of exposure pressure to acclimation pressure (Source: Čada et al. 1997)

More recent investigations have examined the direct effects of pressure stresses on fish under operating conditions representative of conventional hydro projects. As part of the former DOE Advanced Hydropower Turbine System program (AHTS), the Pacific Northwest National Laboratory (PNNL) completed a multi-year laboratory study to quantify the response of fish to rapid pressure changes in a closed laboratory system following acclimation at different depths and gas saturation levels (Abernethy et al. 2001, 2002, 2003) (Figure 2-2). Three species (bluegill, Chinook salmon, and rainbow trout) were exposed to pressure regimes associated with two turbine designs (vertical Kaplan and horizontal bulb units), while maximum and minimum pressure conditions were tested only with the Kaplan design. Results summarized by Becker et al. (2003) supported the conclusion that pressure changes (independent of turbine design) resulted in greater rates of injury and mortality due to swim-bladder rupture for physoclistous fish (bluegill) than for physostomous fish (salmonids). Rates of injury and mortality to both depth- and surface-acclimated salmonids were deemed negligible even at pressure values less than 30% of acclimation pressure. Comparatively, bluegill experienced significant rates of injury and mortality at pressure values below 60% of acclimation pressure, particularly for fish acclimated at depth. Dissolved gas saturation levels were not found to significantly contribute to passage-related injuries or mortalities. From these results, authors suggested that pressures at or above 50 kPa (about 50% of atmospheric pressure or 7 psia) and rates of pressure change at or below 3,500 kPa/s could be expected to provide safe passage for salmonids and would result in limited mortality for physoclistous species such as bluegill (Becker et al. 2003). Also, to eliminate substantial injuries to physoclistous species, it was concluded a higher minimum pressure (greater than or equal to 60% of the fish's acclimation pressure) would likely be necessary.

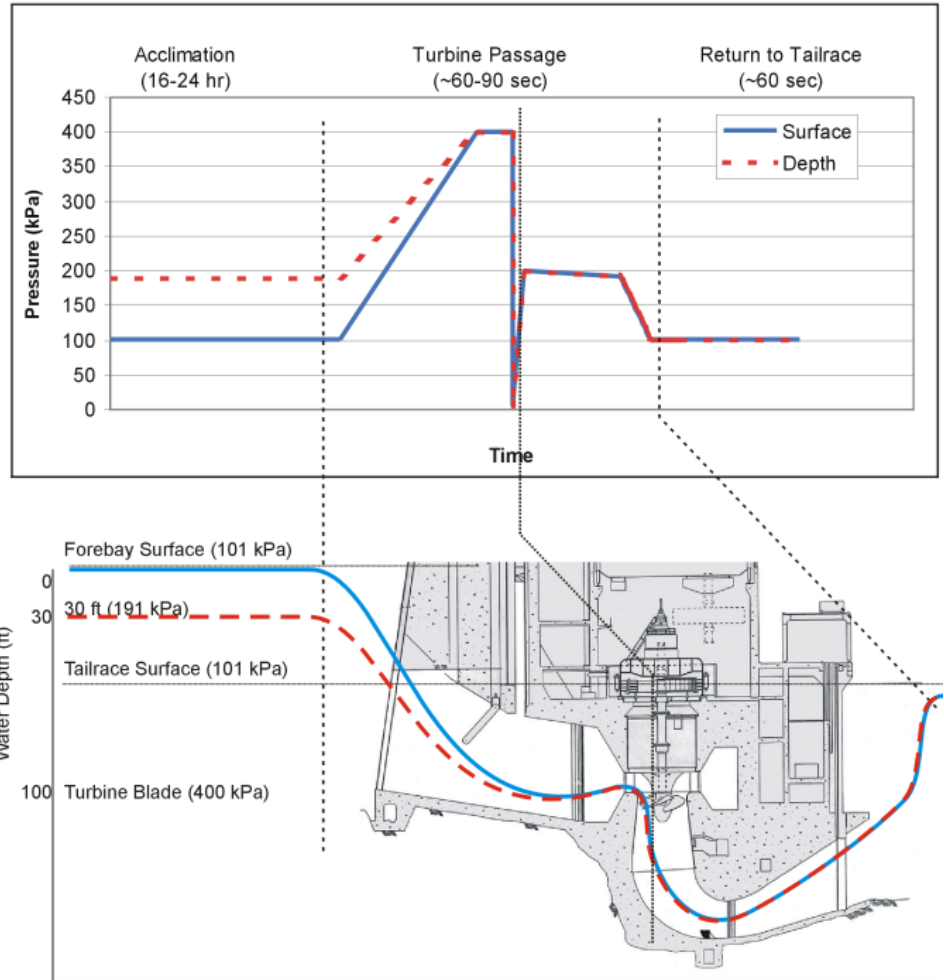

Figure 2-2
 Pressure exposure simulation of turbine passage for surface- and depth-acclimated fish (Source: Abernethy et al. 2001)

Studies employing CFD modeling have allowed investigators to define a given turbine's pressure regime under various operating conditions, including the identification of any areas where damaging pressures may occur. Based on these models, investigators can predict the occurrence of pressure-induced mortality and also verify the predictions by collecting empirical data. As a follow up to an earlier study, Turnpenny et al. (2000) utilized these techniques to refine a method of predicting injury rates resulting from damaging pressures for small, low-head Francis and Kaplan turbines. The authors were able to show that the main risk areas of pressure related injury were located in the turbine runner and the draft tube. Despite this, results of field tests indicated that pressure-related injuries only accounted for 6.3% of the total injuries observed (Turnpenny et al. 2000). Overall, the authors concluded that their predictive model provided a good representation of risk from pressure effects in smaller low head turbines.

In a CFD study of the flow conditions through the pilot-scale Alden turbine, Lin et al. (2004) defined the internal pressure regimes resulting from operation at the best efficiency point (BEP) and off-BEP conditions. The results of this analysis were used to explain observations of similar fish survival rates despite different operating conditions evaluated during a previous pilot-scale biological evaluation of fish passage through the turbine. The Alden turbine had been previously designed to meet established bio-criteria for minimum pressure levels and rates of pressure change (≥ 69 kPa and < 552 kPa/s; Cook et al. 1997). Although the CFD results showed evidence of low pressure zones near the turbine's trailing blade edge at all conditions evaluated, these zones were relatively small in volume and consistent with the more current minimum bio-criteria value (≥ 50 kPa) recommended by Abernethy et al. (2002). Pressure change rates higher than recommended bio-criteria maximum levels ($\leq 3,500$ kPa/sec) were also found near the blade trailing edges for all operating conditions examined, but these rates were also shown to occupy relatively small volumes compared to the entire passage volume of the turbine. After comparing these CFD results with the survival rates observed during the pilot-scale biological evaluation, the authors concluded the established bio-criteria values for minimum pressures and rates of pressure change were reasonable and indicated pressure-related injuries were likely not occurring for fish passing through the Alden turbine.

To further clarify the role of acclimation pressure in effecting pressure-related injuries and mortalities to turbine-passed fish, Carlson and Abernethy (2005) studied the impacts of simulated turbine passage pressure on juvenile salmonids that achieved neutral buoyancy while acclimating to absolute pressures higher than atmospheric levels. This scenario was designed to mimic the acclimation pressures corresponding to the depths at which salmonids had been observed during downstream migration. Prior studies had not allowed salmonids to achieve neutral buoyancy while being acclimated at depth (Abernethy et al. 2001, 2002, and 2003). The results, while lacking statistical significance, indicated that neutrally buoyant juvenile salmonids acclimated at depth pressure levels might be at greater risk for injury and mortality than fish acclimated to near-surface pressures. In a more recent study, Brown et al. (2007) demonstrated that acclimation pressure was a statistically significant predictor for risk of injury or death, but only when fish were exposed to significantly lower simulated turbine minimum pressures in the range of 8–19 kPa.

Review of Cavitation Studies

Cavitation refers to the vaporization and subsequent rapid condensation of water. This process occurs when the localized pressure in water falls to or below the vapor pressure of water at the ambient temperature, resulting in the formation of gas bubbles. These gas bubbles grow in the region of reduced vapor pressure and then collapse suddenly upon reaching areas with higher pressure. The almost instantaneous collapse of bubbles causes high pressure shock waves and noise, the intensity and frequency of which may vary according to bubble size, surrounding water pressure, dissolved gas content, and the presence of air bubbles (Čada et al. 1997).

Within conventional hydro turbines, and depending on air content and water temperature, conditions leading to cavitation may occur on the downstream side of blades, in high-velocity regions, and areas where there are abrupt flow direction changes, or surface roughness (USACE 1995; Čada et al. 1997).

Because cavitation forces are sufficient to cause material damage to turbine components, fish likely would be unable to withstand the same forces produced by collapsing cavitation bubbles, resulting in injury and mortality (Lucas 1962). Turnpenny et al. (1992) performed laboratory experiments to identify the direction that a shock wave traveled following the collapse of a cavitation bubble adjacent to a fish. The collapse behavior of cavitation bubbles next to a fish was compared to that of cavitation next to a solid surface. The results demonstrated that both scenarios resulted in the bubble collapsing asymmetrically, with the implosion directed towards the nearby surface (fish and solid object). While neither the force associated with the collapse nor fish mortality rates were quantified, the authors agreed with previous assumptions that fish would experience cavitation damage within a turbine in this manner. Turnpenny (1992) also noted that cavitation damage within a turbine could be more severe than in his experimental protocol due to the presence of higher energy levels in turbines.

During a 1995 Turbine Passage Survival Workshop held by the U.S. Army Corps of Engineers (USACE 1995), participants agreed that operating turbines at the best efficiency point would likely minimize the occurrence of conditions that lead to cavitation, and therefore should minimize the potential for any subsequent damage to turbine-passed fish resulting from cavitation effects. It was also suggested that the geometry of a turbine runner could be altered to reduce areas of low pressure, high velocity, abrupt changes in flow direction, and surface roughness (Cook et al. 1997), and thereby reduce the potential for cavitation. Due to the pressure conditions necessary for cavitation to occur (water vapor pressure of about 2 kPa), areas of risk within a turbine passageway for both pressure- and cavitation-related damage were expected to be in similar locations. As a result of this relationship, fish damage resulting from cavitation could be minimized in a manner similar to that used to meet the minimum pressure criteria.

Based on the conclusions reached for mitigating pressure effects, Čada et al. (1997) asserted that maintaining water pressures at levels equal to or greater than 60% of ambient fish acclimation pressures within a turbine would also prevent cavitation and any resulting damage to fish. Achieving an average minimum turbine pressure of about 50 kPa (as discussed previously) would be sufficient to suppress cavitation that occurs at a pressure of about 2 kPa. Support for this conclusion has been demonstrated in evaluations of pressure effects related to fish behavior and turbine design criteria (Abernethy et al. 2002, Lin et al. 2004). Even though CFD modeling indicates the formation of low pressure zones near the trailing edge of turbine blades at levels close to vapor pressure, the frequency and volume of these low-pressure zones typically have been shown to be minimal and are very small compared to the overall volume of the turbine passageway.

Potential for Pressure and Cavitation to Injure Fish Passing Through Hydrokinetic Turbines

Because hydrokinetic turbines do not operate under a differential head (water level), pressure changes associated with flow passing through hydrokinetic turbines will be minor and will not be sufficient to cause damage to fish (i.e., the ratio of minimum pressure to acclimation pressure will meet established criteria for preventing fish injury and mortality). Recent reviews of potential environmental effects associated with the operation of hydrokinetic turbines have also reached a similar conclusion (EPRI 2006; DOE 2009).

The typical pressure regimes of flow passing through hydrokinetic turbines are unlikely to cause fish injury and mortality. In addition, regions where cavitation is most likely to occur are relatively small and comprise only a fraction of the total passage volume in a turbine. Regardless, low levels of cavitation associated with local low pressure regions (i.e., below vapor pressure) on the downstream side of rotors and blades may still be present in hydrokinetic turbines and should be addressed in the assessment of potential impacts to fish. Because cavitation can damage equipment and often occurs when turbines are operated under low efficiency conditions, the potential for cavitation and subsequent risks to fish can be minimized or eliminated through blade design and efficient turbine operation that includes a low rpm.

Pressure and Cavitation Bio-Criteria for Hydrokinetic Turbines

Pressure changes associated with hydrokinetic turbines are unlikely to cause injury or mortality to fish that pass through a blade sweep. However, using CFD modeling, turbine developers should confirm that minimum pressures do not fall below 60% of the pressure to which most fish are acclimated or below a minimum absolute pressure of about 50 kPa (7 psia). The 60% criterion for the ratio of minimum exposure pressure to fish acclimation pressure should be easy to achieve for hydrokinetic turbines given that the difference in pressure levels upstream and downstream of a blade sweep will be negligible. Unlike conventional hydro turbines that may pass fish acclimated to surface depths, fish that pass through hydrokinetic turbines should be acclimated to the pressure at the depth of the turbines (i.e., they will not be pulled from shallower depths through an intake structure in the manner that surface-oriented fish are when they pass through conventional hydro turbines). Also, other than localized regions comprising a small percentage of the passage volume, fish will not be exposed to a rapid pressure decrease on the downstream of hydrokinetic turbines following passage through a blade sweep. In addition to meeting the bio-criteria for pressure, potential damage to fish associated with cavitation can be minimized through proper blade design and by operating hydrokinetic turbines at their best efficiency point. Minimizing the probability of occurrence and size of potential cavitation regions should result in negligible impacts to fish associated with this injury mechanism.

Mechanical (Strike and Grinding)

Among the mechanisms that result in direct injury and mortality to fish that pass through conventional hydro turbines, those classified as mechanical in nature are often identified as having the predominant impact. Mechanical effects are related to the structural components of a turbine and are caused by one or more of the following: strike, grinding, and abrasion. A strike is defined as a collision between a fish and either the leading edge of a blade or another structure such as fixed guides, stay vanes, or flow straighteners (Čada et al. 1997). Grinding injuries are a result of fish being drawn into narrow openings or gaps between stationary and/or moving components, including between runner blades and the turbine hub, blade tips and the outer ring, at the top and bottom of wicket gates, or between stay vanes and wicket gates. Abrasion damage is caused by fish rubbing against a moving or stationary surface (USACE 1995).

Review of Blade Strike Studies

For many hydro projects, blade strike may be the primary source of injury and mortality for fish passing through turbines. Many physical and biological factors play a role in determining the probability of a fish being struck by a blade. Due to the difficulty in making direct observations within turbines, blade strike effects were initially defined by calculating strike probability and assuming most, if not all, strikes resulted in mortality. Early theoretical models developed for estimating blade strike probability incorporated information on flow velocity, blade and guide vane angles, blade rotational speed, and fish length (Von Raben 1957; Monten 1985; Solomon 1988). Other predictive models relied on additional biological variables such as fish stiffness and the probability of tissue trauma from a strike of a given force (related to species and age). Although important, these theoretical approaches were based on assumptions that can vary considerably with site-specific conditions. As a result, estimates of strike probability and injury/mortality could exhibit considerable error unless applied to sites with similar design and operation features to those used to develop the predictive models (Čada et al. 1997).

Turnpenny et al. (1992) examined the approach and collision between fish and different blade profiles to establish how fish size, orientation, and position relative to the blade affected the outcome of a strike. These tests were conducted to simulate strike speeds (and blade thicknesses) near the hub and at the blade tip. Results showed that strikes from narrow blade profiles at higher speeds caused severe damage, such as mucous loss, bruising, eye damage, internal bleeding, and broken spines. Conversely, strikes from wider (thicker) blade leading edges at slower speeds caused little damage and no mortality. Turnpenny et al. (1992) also observed that the inertia and orientation of a fish relative to the blade affected strike-related injury and mortality. Fish weighing less than 20 g were swept aside by the blade unless their center of gravity was directly in the blade's path, whereas fish weighing up to 200 g had a 75% chance of being struck when their center of gravity was aligned with the blade's path. Using the results from these tests, Turnpenny et al. (1992) developed equations for low-head, axial-flow tidal turbines based on the theoretical techniques developed by Von

Raben. Calculations of blade strike probabilities accounted for fish length, fish location, fish orientation, fish swimming speed, flow velocity, open space between blades, blade leading edge thickness, and blade speed. In a later study, Turnpenny et al. (2000) modified these statistical methods to predict injury rates for smaller turbines. As would be expected, results showed that rates of strike injury were highly dependent on fish size, turbine type, the runner diameter and rotational rate (rpm), the number of blades, and operating load. In addition, the ratio between strike and mortality was shown to be dependent on fish length.

An examination of the initial studies of blade strike indicated that injury and mortality rates for fish struck by a blade were generally a function of the morphometric characteristics of a given species, turbine design, the spatial aspects of fish passing through a turbine, and the velocity of the fish relative to the velocity of a blade (USACE 1995). It was also concluded that turbine designers could change the probability of strike by altering the number and length of blades, the area per blade channel, the thickness and bluntness of blade leading edges, and the blade tilt.

As part of the former DOE Advanced Hydropower Turbine Systems program, Alden and Concepts NREC conducted a multi-phase research program to design and test a new fish-friendly conventional hydro turbine (Cook et al. 2003). Based on an evaluation of data relevant to injury and mortality of fish passing through turbines, Alden developed the following strike-related biological criteria to guide the selection of fish-friendly features for the new turbine design: (1) peripheral runner (blade tip) speed less than 40 ft/s; (2) minimum number of blades and minimized total leading-edge length of blades; and (3) maximum flow passage size and small clearances between the runner and fixed turbine housing components.

The biological performance of the Alden turbine was evaluated during a pilot-scale laboratory study. Tests were conducted with multiple fish species and sizes, two operating heads (40 and 80 ft), several turbine operating efficiencies, and with and without wicket gates (Hecker et al. 2002; Amaral et al. 2003; Cook et al. 2003). Results of tests conducted with rainbow trout indicated that fish release depth, turbine efficiency, and the presence of wicket gates had no statistically significant influence on survival and injury rates. As was expected, and typical of any turbine design, passage survival decreased with increasing fish size (i.e., strike probability and mortality increases with fish length). Using the pilot-scale test data and a standard turbine blade strike probability model, estimates of strike were calculated for a full-scale prototype unit at the heads evaluated during the laboratory study (40 and 80 ft). High survival rates (> 96%) were predicted for fish up to 200 mm in length for both operating heads. The biological evaluation of the Alden turbine demonstrated that the fish-friendly features incorporated into the design contributed to low injury and mortality rates and that blade strike was the primary mechanism of damage to fish.

To further assess fish survival through a prototype Alden turbine in a real world application, Hecker and Allen (2005) used an established strike probability model and available strike mortality data to account for the effects of fish length and the relative velocity of turbine inflow to blade speed (i.e., strike velocity). Both of these parameters influence strike injury and mortality rates and strongly influence the proportion of struck fish that are killed. The resulting predictive model was used to estimate turbine passage survival rates for the Alden turbine and a Kaplan with a minimum gap runner (MGR), both designed for the same site conditions (approximate turbine discharge of 1,500 cfs and head of 92 ft). Using this approach, 100-mm fish passing through the Alden turbine were estimated to have mortality about one fifth that of the same size fish passing through the MGR Kaplan. The primary reasons for the Alden turbine having considerably less fish mortality were lower inflow-to-blade velocity (i.e., strike velocity), lower rotational speed, more tangential absolute flow velocity, and half the number of blades (three for the Alden turbine versus six for the MGR Kaplan). The primary conclusion from this study was that strike-induced mortality would be reduced in turbines with larger diameters (i.e. lower rpm), fewer blades, and lower inflow-to-blade velocities.

Ploskey and Carlson (2004) were able to verify a predictive blade strike probability model by estimating blade strike and injury at two turbines at Bonneville Dam and comparing the results to direct turbine survival data collected during a field study (NAI et al. 2000). The field study examined fish passage survival for specific passage routes through a turbine's runner that were based on the release depth of fish in the turbine intake. The results of the field study demonstrated that fish injury and mortality rates were higher when fish passed closer to the blade tips (thinner and faster leading edge) compared to passing near the runner hub (thicker and slower leading edge). Ploskey and Carlson (2004) used deterministic and stochastic versions of a previously developed predictive model (Turnpenny et al. 2000) which calculated strike probability estimates as a function of fish length and the turbine geometry. Overall, Ploskey and Carlson (2004) concluded that the location along the length of a turbine blade from the hub to the tip where a fish passes and the orientation of the fish when encountering a leading edge were significant factors in the successful application of theoretical blade-strike models.

In a similar study, Deng et al. (2005) evaluated the validity of estimating strike probability to establish a turbine's biological performance. To do this, modifications were made to the predictive model developed by Turnpenny et al. (2000) to account for the potential effects of wicket gate geometry and water velocity on turbine passage survival. Using the modified model, deterministic and stochastic predictions that considered how fish orient to an approaching blade were compared with biological field data collected during field studies (NAI et al. 2000). In addition, the study authors compared their predictions with observations of neutrally-buoyant beads interacting with runner blades in a scaled physical model. Results from bead testing showed that a bead's release location affected its route of passage. Beads released at the top of the wicket gates passed close to the runner hub, whereas those released near the middle and bottom of the wicket gates passed close to the mid blade and blade tips, respectively.

Stochastic predictions of turbine passage survival were similar to two sets of empirical data, and the orientation of fish as they encounter a blade's leading edge was a significant factor in determining strike probability and mortality. It was concluded that fish orientation can affect the results of predictive models and should be studied further to improve their reliability.

With the knowledge that blade strike does not always result in mortality (Turnpenny et al. 1992), a multi-year study was initiated by EPRI to evaluate the importance of leading edge blade thickness, shape, and impact velocity on fish survival (Hecker et al. 2007; Amaral et al. 2008; EPRI 2008, 2011). The goal of this study was to determine the optimum blade geometry (including thickness) for maximizing survival of fish struck by turbine blades. The researchers used CFD modeling and laboratory testing with fish to develop leading edge blade design criteria. Results from the CFD analysis indicated that a semi-circular shaped blade created the highest differential forces (leading edge pressures) and thus had the greatest potential to deflect a fish prior to impact. In the first year of laboratory testing, rainbow trout of various lengths (about 100 to 250 mm) were exposed to semi-circular blades of differing thicknesses (9.5, 25.4, 50.8, 101.6, and 152.4 mm) traveling at speeds up to about 30 ft/sec. The ratio of fish length to blade thickness (L/t) was used to standardize the results. During the second year, the scope of testing was expanded to include two additional species (white sturgeon and American eel) and higher strike speeds (up to 40 ft/s).

Rainbow trout had high strike survival rates (> 90%) at strike velocities up to about 40 ft/s when the L/t ratio was about 1 or less (i.e., fish length was equivalent to or greater than the leading edge blade thickness) (Figure 2-3). Conversely, increases in L/t ratios above 1 at strike velocities of about 24 ft/s resulted in dramatic decreases in survival (Figure 2-3). These results demonstrated that strike survival was influenced by strike velocity, fish length, and blade thickness. White sturgeon and American eel exhibited higher blade strike survival rates than rainbow trout at equivalent L/t ratios, as well as high survival rates at L/t ratios and strike speeds greater than those tested with rainbow trout. Investigators concluded that unique physical features of sturgeon and eel made them less susceptible to strike-related injury (Amaral et al. 2008; EPRI 2008). The results of this study provide valuable information with respect to making turbine blades less injurious to fish.

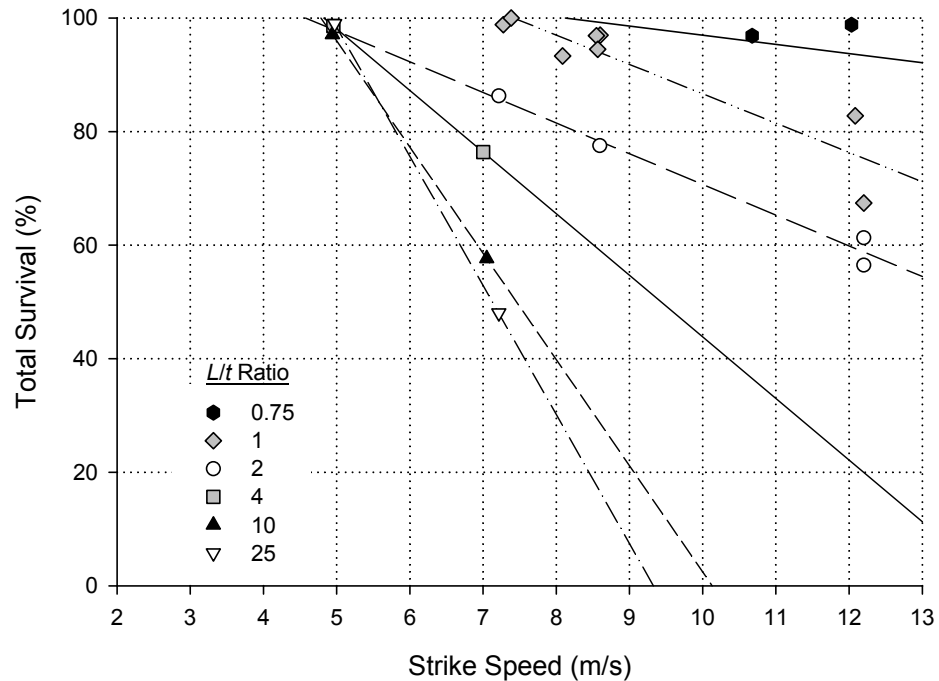

Figure 2-3
Blade strike survival rates of rainbow trout tested at various fish length to leading edge thickness ratios (L/t) over a range of strike velocities (Source: EPRI 2011)

Review of Grinding and Abrasion Studies

Due to limited information and data, the extent to which fish passing through conventional hydro turbines are injured and killed from grinding and/or abrasion is not completely known. Clearly, there is potential for fish to be caught between moving and stationary turbine components or to pass through gaps or contact rough surfaces resulting in injury, but these injury mechanisms have not been quantified to any reasonable extent for conventional hydro turbines. Despite the lack of data, efforts have been made to improve the fish-friendliness of conventional hydro turbines by reducing the potential for grinding and abrasion. In particular, a minimum gap runner (MGR) design for Kaplan turbines was developed through the former DOE Advanced Hydro Turbines Systems program by a team of researchers led by Voith Hydro (Franke et al. 1997). The MGR design greatly reduced the gap between the blade tips and outer ring and between the blades and the hub. Modifications were also made to stay vanes and wicket gates to reduce gaps associated with these components. The design of hydrokinetic turbines should also incorporate features that will prevent or reduce grinding and abrasion of fish, e.g., reduce the gaps between the rotor blade tips and duct. However, because hydrokinetic turbines have an open flow path and inherently fewer components that could lead to grinding and abrasion injuries, the reduction of these injury mechanisms should be secondary to more prevalent sources of potential injury (e.g., blade strike).

Potential for Mechanical Injury to Fish Passing Through Hydrokinetic Turbines

Mechanical mechanisms of fish injury and mortality associated with hydrokinetic turbines will be similar to those experienced by fish passing through conventional hydro turbines. However, the potential for grinding and abrasion is likely to be minimal (or possibly absent for some hydrokinetic turbine designs) given that there are fewer locations where these types of injuries could occur during passage through hydrokinetic turbines. Specifically, there are typically no structures upstream and downstream of hydrokinetic rotors that can result in abrasion, and there are few gaps between turbine components where grinding may occur. Some hydrokinetic turbines have stators that direct flow to the turbine blades and which may create opportunities for grinding or pinching in the space between the stators and rotors.

Because opportunities for abrasion and grinding are limited, the primary source of mechanical-related fish injury and mortality associated with hydrokinetic turbines will be blade strike. Fish striking fixed turbine components, such as stators or an outer ring (ducted units), should not result in injury because of relatively low approach velocities (typically less than 10 ft/s). Most species and life stages will have sufficient swimming capabilities to avoid collision with stationary structures at the velocities approaching hydrokinetic turbines, and existing blade strike data demonstrate that collisions at these velocities will not result in injury. Even if such collisions occur, the low strike velocities will not result in injury or mortality based on data from turbine blade strike studies conducted at strike velocities between about 15 and 40 ft/s (Hecker et al. 2007; Amaral et al. 2008; EPRI 2008). Therefore, strike by moving turbine blades may be the primary potential source of mechanical injury for fish passing through hydrokinetic turbines. Mortality from strike could occur if the relative velocity of fish to blades (i.e., strike velocity) and the ratio of fish length to leading edge blade thickness are sufficiently high to cause physical harm (Hecker et al. 2007; Amaral 2008; EPRI 2008). However, even if strike velocities are sufficiently high to injure fish, the probabilities that fish will encounter a turbine may be very low and, for those that do approach a turbine, active avoidance of turbine passage and moving blades may be high, resulting in little or no strike-related mortality.

Mechanical Bio-Criteria for Hydrokinetic Turbines

To minimize the potential for fish injury and mortality associated with mechanical components, device developers should consider the following in the design of hydrokinetic turbines:

- Minimize the number and size of gaps between stationary and moving components.
- Minimize the size of gaps between stationary components.
- Maximize the size of gaps between trailing edge of stators and turbine blades.
- Minimize the number of blades.

- Maximize the thickness of the blade leading edges and approximate a semi-circular leading edge shape.
- Minimize blade speed. Blade speeds and approach velocities that result in strike velocities of about 15 ft/s and less will result in minimal or no injury to all species and life stages (except possibly early larval fish); injury and mortality at higher speeds will depend on the ratio of fish length to the leading edge blade thickness.

The actual effects of each of these turbine design features on levels of fish injury and mortality may be difficult to isolate and quantify for some hydrokinetic turbine designs. However, strike probability and mortality models can be used to estimate and compare the biological performance of various design alternatives with respect to the potential for blade strike. Also, adherence to the above criteria may not be necessary if it can be determined that encounter probabilities will be low and/or active avoidance of a turbine and moving blades will be high. Similarly, if strike velocities will be about 15 ft/s or less (criteria for no strike-related mortality), attention to other fish-friendly features would not be required (e.g., gap sizes and blade thickness).



Section 3: Summary and Conclusions

Several previous studies have identified potential environmental impacts associated with the installation and operation of hydrokinetic turbines in riverine, tidal, and marine areas with sufficient water velocities for power production (Coutant and Čada 2005; EPRI 2006; Čada et al. 2007; DOE 2009). In particular, these studies have listed many of the injury mechanisms that have been shown to cause damage to fish passing through conventional hydro turbines (e.g., blade strike and damaging shear and pressure conditions). Because the goal of these studies was to identify and describe potential impacts, detailed assessments of the relative importance or likelihood of various injury mechanisms for fish exposed to hydrokinetic turbines was typically not provided. However, general conclusions from some of these studies suggested that fish should suffer less injury and mortality passing through hydrokinetic turbines due to less severe conditions associated with specific design and operational features known to contribute to injury of entrained fish. Some of these studies also recommended that a more detailed analysis of fish injury and mortality data from research examining the environmental impacts of other energy sources be conducted, with specific references to extensive research on fish passage through conventional hydro turbines. The review of existing information provided in this report focuses on conventional hydro studies and provides a more thorough assessment of its relevance to hydrokinetic power generation.

There are many factors that need to be considered and understood in order to determine the potential impacts of hydrokinetic turbines on fish populations in riverine and tidal environments. The potential for injury and mortality of fish passing through the blade sweep of hydrokinetic turbines appears to be one of the most prevalent concerns raised by resource agencies and other interveners during the FERC licensing process for pilot projects. This report addresses this concern by examining information and data describing the injury mechanisms for fish passing through conventional hydro turbines and how that information may be relevant to assessing impacts of hydrokinetic projects. However, the hydraulic, mechanical, physical environment experienced by fish entrained through conventional hydro turbines is typically much harsher than what is experienced by fish passing through the blade sweep of a hydrokinetic turbine. This is mainly due to conventional turbines being operated under static head, whereas hydrokinetic units extract energy from ambient current velocities, typically without using any structures to create head or constrain flow through the turbines. The design and operation of conventional turbines results in high flow velocities, abrupt changes in flow direction, relatively high turbine rotational and blade speeds, rapid and significant changes in pressure, and the need for various structures throughout the turbine

passageway that can be impacted by fish (e.g., walls, stay vanes, wicket gates, flow straighteners). Most, if not all, of these conditions do not occur or are not a component of hydrokinetic turbines and, therefore, they generally are not experienced by fish that approach and pass through the blade sweep of a hydrokinetic turbine. Also, when compared to conventional hydro turbines, the operation of hydrokinetic turbines typically produces relatively minor changes in shear, turbulence, and pressure levels from ambient conditions in the surrounding environment. Injuries and mortality from mechanical injuries will be less as well, mainly due to low rotational speeds and strike velocities, and an absence of structures that can lead to grinding or abrasion injuries. A comparison of the design and operational features associated with conventional hydro and hydrokinetic turbines presented in Table 3-1 demonstrates why rates of injury and mortality will be lower with exposure to hydrokinetic turbines.

*Table 3-1
Comparison of design and operational features associated with conventional hydro and hydrokinetic turbines*

Parameter	Conventional Hydro	Hydrokinetic
Flow path	Turbines Spill and sluice gates Spillway Fish bypasses	Turbines Free-flowing area around turbines
Infrastructure	Dam (spillway and gates) Intake structure with trash rack Penstocks and scroll cases Stay vanes and wicket gates Draft tube Fish passage facilities	Piers and/or anchors
Power (mid-size unit)	10 MW	100 kW
Head maintained for power production	10 - 1,000 ft	None
Number of blades	Kaplan: 4 - 6 Francis: 14 - 18	Horizontal axis: 2 - 16 Cross-flow: 3 or 4
Pressure change	Head dependent; > 1 atmosphere (about 100 kPa) or more	Small pressure change from upstream to downstream
Approach velocity	> 6 m/s	1 to 4 m/s
Rotational speed	60 to 600 rpm	Horizontal-axis propeller: < 100 rpm
Number of exposures to runner	1	Cross-flow: 50 to 150 rpm Multiple, depending on number of turbines in project

As presented in this report, extensive research has been conducted on injury mechanisms associated with fish passage through conventional hydro turbines. Bio-criteria developed from these studies for determining the ability of fish to safely pass through a turbine are relevant to hydrokinetic turbines and indicate that injury and mortality rates will be lower for fish passing through hydrokinetic turbines. However, more information is needed to define what fish experience when passing through hydrokinetic turbines in order to fully demonstrate that injury and mortality will not occur or will be negligible for fish passing through a turbine's blade sweeps. For any given hydrokinetic turbine design, information on pressure changes, cavitation, shear strain rates, and strike probability and mortality rates can be developed and compared to existing bio-criteria in order to determine fish-friendliness and ways that turbine design and operation can be modified, if needed, to reduce the potential for injury to entrained fish. For some applications and technologies, it may be important to support these conclusions using CFD modeling to identify areas where bio-criteria for acceptable pressure conditions (including the absence of cavitation) and shear levels may be exceeded, and by conducting flume and/or field studies to validate strike probability and mortality predictions. A summary of recommended bio-criteria for that should be met for safe fish passage through hydrokinetic turbines is provided in Table 3-2.

*Table 3-2
Recommended bio-criteria for hydrokinetic turbines*

Injury Mechanism	Suggested criteria
Pressure	Minimum: 50 kPa (7.4 psia)
Shear (stain rate)	Maximum 500/sec
Mechanical	Minimize gaps between turbine components
Blade strike	Minimize number of blades Design for strike velocities of less than 4.8 m/s Design blades with blunt leading edges if strike velocities exceed 4.8 m/s

Another factor that will influence potential effects of hydrokinetic turbines on fish that has not been adequately addressed is the proportion of fish that move downstream past turbines installed in riverine or tidal locations that actually encounter a turbine and are entrained through the blade sweep. Evidence from studies conducted at the RITE project on the East River in New York indicate that fish may avoid turbine impact zones (i.e., abundance was greater in non-impact zones; Verdant Power 2010). The most simplistic approach to addressing this issue would be to assume fish are uniformly distributed across a river or tidal reach and, therefore, the number (or percent) of fish exposed to a turbine is proportional to the cross sectional area of a turbine versus the entire cross section of the channel. For example, if the blade sweep of one or more turbines covers 25% of the cross sectional area of channel then it would be assumed that 25% of fish moving downstream would approach and potentially pass through the blade sweep. However, fish distributions will vary with species and life stages, with some being concentrated along shorelines and others preferring mid-channel habitats. Depth preferences (i.e., benthic or pelagic) will also affect fish

distributions vertically within a channel. Consequently, some species and life stages may never encounter hydrokinetic turbines depending on their habitat preferences and where turbines are located (Cada and Bevelhimer 2011, Schweizer et al. 2011). A similar approach would be to assume that the number (or percent) of fish entrained is proportional to the volume of water passing through a turbine's blade sweep compared to the total channel discharge (i.e., if 25% of the channel discharge is passing through a turbine's blades, then 25% of fish also encounter the blade sweep). The flow volume method has often been used to provide gross estimates of fish entrainment at water intakes (including at hydroelectric projects). Alternatively, encounter rates could be higher than might be implied by the fractional cross section or flow intercepted by the turbines if fish distribution were biased toward these areas.

Even if fish encounter a hydrokinetic turbine, entrainment through the blade sweep may not occur if fish exhibit avoidance behavior and swim away from and around a turbine (EPRI 2011). Fish that are entrained may also be capable of avoiding blade strike by taking evasive actions as a blade approaches. The burst swimming capabilities of many species and life stages could easily allow fish to avoid being struck by an oncoming blade. The ability of fish to detect hydrokinetic turbines and react quickly enough to avoid entrainment or blade strike will depend on many factors, including, but not limited to, turbine noise (both acoustic and hydrodynamic), ambient light conditions, turbidity, physiological state/health of the fish, and species-specific sensory perception capabilities. Also, the probability of entrainment and blade strike may be affected by schooling behavior because lead fish will typically influence the path of a school and reactions to hydraulic disturbances, underwater structures and objects, and the presence of predators or prey. Depending on how lead fish react to hydrokinetic turbines, schooling may result in either higher or lower rates of entrainment and blade strike.

Similar to conventional turbines, the probability of strike for fish passing through hydrokinetic turbines is primarily dependent on approach velocity, rotational speed, and fish length. For fish that are struck, the probability of mortality is dependent on blade and flow velocities (and the consequent relative velocity of fish to blade), leading edge blade thickness, orientation of fish (i.e., angle to blade), sensitivity of the fish to strike forces, and fish length. Combining strike probability with strike mortality provides a measure of turbine passage survival, assuming no mortality occurs due to damaging pressure or shear conditions. The estimation of strike probability and mortality does not account for fish that actively avoid passage through an operating turbine or that evade an oncoming blade. Also, unlike for conventional hydro turbines where inflow velocities are high (greater than 15 ft/s) and it can be reasonably assumed fish are traveling at the speed of the water, assumptions for estimating strike probability must be made regarding the speed of fish approaching hydrokinetic turbines that may not be reliable because approach velocities are much lower (less than 10 ft/s). At the range of velocities over which many hydrokinetic turbines operate, most fish will have the ability to move through the blade sweep slower or faster than the approaching flow. If fish pass through a turbine's blade sweep slower than the approach velocity, strike probabilities will be higher than if they were moving at the speed of the ambient current; for fish moving faster than the flow, strike probabilities will be lower.

Our review of the literature on fish passage through conventional hydro turbines and its relevance to hydrokinetic turbines focused primarily on the effects of fish passing through a single turbine and does not fully address effects of hydrokinetic installations with multiple turbines. The number of fish exposed to turbine passage and the overall turbine passage mortality rates for an array of hydrokinetic turbines likely will be higher for multiple units compared to the operation of a single unit, but it is not yet known whether these increases would be proportional to the number of turbines. Future analyses will need to be conducted, perhaps on a site-specific basis, to account for the effects of multiple turbines and to consider hydraulic, environmental, and biological factors that will influence the potential for adverse effects on fish and to confirm the findings of this study. A detailed assessment of potential impacts will also need to determine the proportion of fish that will encounter a turbine or an array of turbines and, of those that do, what is the probability of avoidance. When encounter and avoidance probability rates are combined with expected survival rates for passage through the blade sweep of one or more turbines, an overall survival rate can be developed for fish populations in the vicinity of a hydrokinetic project. Finally, our review and assessment of conventional hydro data pertains to direct mortality from injury mechanisms associated with turbine passage. Indirect mortality (e.g., predation, disease) may result from sub-lethal injuries, increased stress, reduced fitness, and/or disorientation. Similar to direct mortality, the occurrence of injuries and physiological conditions that may lead to indirect mortality should be less than is experienced by fish passing through the harsher environment of conventional turbines. A review of indirect mortality studies conducted for conventional hydro projects may also be warranted to address this issue at hydrokinetic installations.

Turbine passage survival rates for conventional hydropower projects have generally been shown to range from about 70 to 97% (Franke et al. 1997; EPRI 1997), with the lower survival rates being representative of larger fish and/or Francis turbines (i.e., large number of blades and high rotational speeds) and the higher survival rates being representative of smaller fish and/or Kaplan turbines (fewer blades and lower rotational speeds). Based on the assessment of injury mechanisms provided in this report and their relevance and applicability to hydrokinetic turbines, survival of fish passing through hydrokinetic turbines will be greater than has been reported for conventional hydro. In addition, recent lab and field studies of fish passage through hydrokinetic turbines have reported direct survival rates of adult fish greater than 98% for three hydrokinetic turbine designs (one cross-flow and two horizontal-axis ducted turbines) (NAI 2009; EPRI 2011). These lab and field data and the review of conventional hydro data indicate hydrokinetic turbines are likely to achieve turbine passage survival rates exceeding 98% for a wide range of species and life stages. When combined with encounter and avoidance probabilities, as discussed previously, overall passage survival for fish moving past a hydrokinetic turbine may exceed 99% for many designs. Field monitoring studies focused on fish behavior and survival at selected projects will be needed to verify the information presented in this report and to expand the existing dataset developed from previous lab and field studies.



Section 4: Literature Cited

Abernethy, C. S., B. G. Amidan, G. F. Čada. 2001. Laboratory Studies of the Effects of Pressure and Dissolved Gas Supersaturation on Turbine-Passed Fish. U.S. Department of Energy, PNNL-13470.

Abernethy, C. S., B. G. Amidan, G. F. Čada. 2002. Fish Passage Through a Simulated Modified Kaplan Turbine Pressure Regime: A Supplement to “Laboratory Studies of the Effects of Pressure and Dissolved Gas Supersaturation on Turbine-Passed Fish.” U.S. Department of Energy, PNNL-13470-A.

Abernethy, C. S., B. G. Amidan, G. F. Čada. 2003. Fish Passage Through a Simulated Horizontal Bulb Turbine Pressure Regime: A Supplement to “Laboratory Studies of the Effects of Pressure and Dissolved Gas Supersaturation on Turbine-Passed Fish.” U.S. Department of Energy, PNNL-13470-B.

Amaral, S. G. Hecker, M. Metzger, and T. Cook. 2003. 2002 Biological Evaluation of the Alden/Concepts NREC Turbine. Proceedings of Waterpower XIII, HCI Publications, Inc., St. Louis, Missouri.

Amaral, S. V., G. E. Hecker, P. Stacy, and D. A. Dixon. 2008. Effects of leading edge turbine blade thickness on fish strike survival and injury. Proceedings of Hydrovision 2008. HCI Publications, St. Louis, Missouri.

ARL (Alden Research Laboratory, Inc.). 1996. Development of a More Fish Tolerant Turbine Runner. Technical Memorandum #2: Development of Biological Design Criteria.

Becker, J. M., C. S. Abernethy, and D. D. Dauble. 2003. Identifying the Effects on Fish of Changes in Water Pressure During Turbine Passage. Hydro Review, September 2003, HCI Publications, Inc., St. Louis, Missouri.

Brown, R.S., T.J. Carlson, A.E. Welch, J.R. Stephenson, C.S. Abernethy, C.A. McKinstry, and M.H. Theriault. 2007. Assessment of Barotrauma Resulting from Rapid Decompression of Depth-Acclimated Juvenile Chinook Salmon Bearing Radio Telemetry Transmitters. Prepared for the U.S. Army Corps of Engineers by Battelle – Pacific Northwest Division, Richland, Washington. PNNL-16790. September 2007.

Čada, G. F. 1990. A Review of Studies Relating to the Effects of Propeller-Type Turbine Passage on Fish Early Life Stages. *North American Journal of Fisheries Management* 10:418-426.

Čada, G. F., C. C. Coutant, and R. R. Whitney. 1997. Development of Biological Criteria for the Design of Advanced Hydropower Turbines. DOE/ID-10578, Oak Ridge National Laboratory, Oak Ridge, Tennessee.

Čada, G. F. 2001. The Development of Advanced Hydroelectric Turbines to Improve Fish Passage Survival. *Fisheries* 26:14-23.

Čada, G., J. Loar, L. Garrison, R. Fisher, D. Neitzel. 2006. Efforts to Reduce Mortality to Hydroelectric Turbine-Passed Fish: Locating and Quantifying Damaging Shear Stresses. *Environmental Management* 37(6):898-906.

Čada, G., J. Ahlgrimm, M. Bahleda, T. Bigford, S. Stavrakas, D. Hall, R. Moursund, and M. Sale. 2007. Potential impacts of hydrokinetic and wave energy conversion technologies on aquatic environments. *Fisheries* 32(4): 174-181.

Čada, G. F. and M. S. Bevelhimer. 2011. *Attraction to and Avoidance of Instream Hydrokinetic Turbines by Freshwater Aquatic Organisms*. Oak Ridge National Laboratory. ORNL/TM-2011/131. May 2011.

Carlson, T. J. and C. S. Abernethy. 2005. Pilot Study of the Effects of Simulated Turbine Passage Pressure on Juvenile Chinook Salmon Acclimated with Access to Air at Absolute Pressures Greater than Atmospheric. Prepared for the U.S. Army Corps of Engineers, Portland District by Battelle – Pacific Northwest Division, Portland, Oregon. PNNL-15011. May 2005.

Cook, T. C., G. E. Hecker, H. B. Faulkner, and W. Jansen. 1997. Development of a More Fish Tolerant Turbine Runner, Advanced Hydropower Turbine System. Prepared for the U.S. Department of Energy. Prepared for the U.S. Army Corps of Engineers, Portland District, Portland, Oregon. Pacific Northwest National Laboratory Report No. PNNL-15011

Cook, T. C., G. E. Hecker, S. V. Amaral, P. S. Stacy, F. Lin, and E. P. Taft. 2003. Final Report – Pilot-Scale Tests Alden/Concepts NREC Turbine. Prepared for U.S. Department of Energy, Advanced Hydropower Turbine Systems Program.

Coutant, C.C., and G.F. Čada. 2005. What's the Future of Instream Hydro? *Hydro Review* 24(6): 42-49. HCI Publications, St. Louis, Missouri.

Dadswell, M. J., R. A. Rulifson, and G. R. Daborn. 1986. Potential Impact of Large Scale Tidal Power Developments in the Upper Bay of Fundy on Fisheries Resources of the Northwest Atlantic. *Fisheries* 11:26-35.

Dauble, D. D., Z. D. Deng, M. C. Richmond, R. A. Moursund, T. J. Carlson, C. L. Rakowski, and J. P. Duncan. 2007. Biological Assessment of the Advanced

Turbine Design at Wanapum Dam, 2005. Prepared for the U.S. Department of Energy, Office of Energy Efficiency and Renewable Energy, Wind and Hydropower Technologies. Pacific Northwest National Laboratory Report No. PNNL-16682.

Deng, Z., T. J. Carlson, G. R. Ploskey, and M. C. Richmond. 2005. Evaluation of Blade-Strike Models for Estimating the Biological Performance of Large Kaplan Hydro Turbines. U.S. Department of Energy, Office of Energy Efficiency and Renewable Energy, Wind and Hydropower Technologies, PNNL-15370.

DOE (U.S. Department of Energy). 2009. Report to Congress on the Potential Environmental Effects of Marine and Hydrokinetic Energy Technologies. U.S. Department of Energy, Office of Energy Efficiency & Renewable Energy, Wind and Hydropower Technologies Program, DOE/GO-102009-2955.

EPRI (Electric Power Research Institute). 2006. Instream Tidal Power in North America, Environmental and Permitting Issues. EPRI-TP-007-NA. Prepared by Devine Tarbell & Associates, Inc., Portland, Maine, for Electric Power Research Institute, Palo Alto, California.

EPRI (Electric Power Research Institute). 2008. Evaluation of the effects of turbine blade leading edge design on fish survival. Prepared by Alden Research Laboratory, Inc., EPRI Report No. 1014937.

EPRI (Electric Power Research Institute). 2011. Evaluation of Fish Injury and Mortality Associated with Hydrokinetic Turbines. Prepared by Alden Research Laboratory, Inc. EPRI Report No. TR-1024569.

EPRI (Electric Power Research Institute). In press. Additional Tests Examining Survival of Fish Struck by Turbine Blades. Prepared by Alden Research Laboratory, Inc.

Feathers, M. G., and A. E. Knable. 1983. Effects of depressurization upon largemouth bass. *North American Journal of Fisheries Management* 3:86-90.

Foye, R. E., and M. Scott. 1965. Effects of pressure on survival of six species of fish. *Transactions of the American Fisheries Society* 94:88-91.

Franke, G. F., D. R. Webb, R. K. Fisher, D. Mathur, P. N. Hopping, P. A. March, M. R. Headrick, I. T. Laczko, Y. Ventikos, and F. Sotiropoulis. 1997. Development of Environmentally Advanced Hydropower Turbine System Concepts. Prepared for the U.S. Department of Energy, Voith Hydro, Inc. Report No. 2677-0141.

Guensch, G. R., R. P. Mueller, C. A. McKinstry, D. D. Dauble. 2002. Evaluation of Fish-Injury Mechanisms During Exposure to a High-Velocity Jet. U.S. Department of Energy, DOE/ID-11072, PNNL-14173.

- Harvey, H. H. 1963. Pressure in the early life history of sockeye salmon. Doctoral dissertation, University of British Columbia, Vancouver.
- Hecker, G., S. Amaral, P. Stacy, T. Cook, M. Metzger, and B. McMahon. 2002. Engineering and Biological Evaluation of the Alden/Concepts NREC Turbine. Proceedings of Hydrovision 2002, HCI Publications, Inc., St. Louis, Missouri.
- Hecker, G. E., and G. S. Allen. 2005. An Approach to Predicting Fish Survival for Advanced Technology Turbines. Hydro Review, November 2005, HCI Publications, Inc., St. Louis, Missouri.
- Hecker, G. E., S. V. Amaral, P. Stacy, and D. A. Dixon. 2007. Developing turbine blades to minimize fish mortality. Proceedings of Waterpower XV. HCI Publications, St. Louis, Missouri.
- Killgore, K. J., A. C. Miller, and K. C. Conley. 1987. Effects of turbulence on yolk-sac larvae of paddlefish. Transactions of the American Fisheries Society 116:670-673.
- Killgore, K. J., S. T. Maynard, M. D. Chan, and R. P. Morgan. 2001. Evaluation of Propeller-Induced Mortality on Early Life Stages of Selected Fish Species. North American Journal of Fisheries Sciences 21:947-955.
- Lin, F., G. E. Hecker, and T. C. Cook. 2004. Understanding Turbine Passage Survival Using CFD. Proceedings of Hydrovision 2004, HCI Publications, Inc., St. Louis, Missouri.
- Lucas, K. C. 1962. The Mortality of Fish Passing through Hydraulic Turbines as related to Cavitation and Performance Characteristics, Pressure Change, Negative Pressure, and Other Factors. *In*: Proceedings of the Symposium on Cavitation and Hydraulic Machinery, Sendai, Japan.
- McEwen, D., and G. Scobie. 1992. Estimation of the Hydraulic Conditions Relating to Fish Passage through Turbines. NPC001. National Engineering Laboratory, East Kilbride, Glasgow, Scotland.
- Monten, E. 1985. Fish and Turbines: Fish Injuries during Passage through Power Station Turbines. Vattenfall, Stockholm, Sweden.
- Montgomery Watson. 1995. Allowable Gas Supersaturation for Fish Passing Hydroelectric Dams. Project No. 93-8. Final report prepared for Bonneville Power Administration, U.S. Department of Energy, Portland, Oregon.
- Morgan, R.P., R.E. Ulanowicz, V.J. Rasin, Jr., L.A. Noe, and G.B. Gray. 1976. Effects of shear on eggs and larvae of striped bass, *Morone saxatilis*, and white perch, *M. americana*. Transactions of the American Fisheries Society. 105(1): 149-154.

Neitzel, D.A., M.C. Richmond, D.D. Dauble, R.P. Mueller, R.A. Moursund, C.S. Abernethy, G.R. Guensch, and G.F. Čada. 2000. Laboratory Studies on the Effects of Shear on Fish: Final Report. U.S. Department of Energy, Idaho Operations Office, DOE/ID-10822, Idaho Falls, Idaho.

Neitzel, D. A., D. D. Dauble, G. F. Čada, M. C. Richmond, G. R. Guensch, R. P. Mueller, C. S. Abernethy, and B. Amidan. 2004. Survival Estimates for Juvenile Fish Subjected to a Laboratory-generated Shear Environment. Transactions of the American Fisheries Society 133:447-454.

NAI et al. (Normandeau Associates, Inc., J. R. Skalski, and Mid Columbia Consulting, Inc.) 2000. Direct Survival and Condition of Juvenile Chinook Salmon Passed Through an Existing and New Minimum Gap Runner Turbines at Bonneville Powerhouse, Columbia River. Prepared for Portland District, U.S. Army corps of Engineers, Portland, Oregon.

NAI (Normandeau Associates, Inc.), J. R. Skalski, and Mid Columbia Consulting, Inc. 2006. Fish Survival Investigation Relative to Turbine Rehabilitation at Wanapum Dam, Columbia River, Washington. Prepared for Public Utility District No. 2 of Grant County, Ephrata, WA.

NAI (Normandeau Associates, Inc.). 2009. An Estimation of Survival and Injury of Fish Passed through the Hydro Green Energy Hydrokinetic System, and a Characterization of Fish Entrainment Potential at the Mississippi Lock and Dam No. 2 Hydroelectric Project (P-4306), Hastings, Minnesota. Prepared for Hydro Green Energy LLC, Houston, Texas.

Odeh, M, J. F. Noreika, A. Haro, A. Maynard, T. Castro-Santos, and G. F. Čada. 2002. Evaluation of the Effects of Turbulence on the Behavior of Migratory Fish. Prepared for the Bonneville Power Administration, Report No. DOE/BP-00000022-1.

Ploskey, G. R., and T. J. Carlson. 2004. Comparison of Blade-Strike Modeling Results with Empirical Data. U.S. Department of Energy, Office of Energy Efficiency and Renewable Energy, Wind and Hydropower Technologies, PNNL-14603.

Rowley, W. E. 1955. Hydrostatic Pressure Tests on Rainbow Trout. California Fish and Game 41:243-284.

Schweizer, P. E., G. F. Cada and M. S. Bevelhimer. 2011. *Estimation of the Risks of Collision or Strike to Freshwater Aquatic Organisms Resulting from Operation of Instream Hydrokinetic Turbines*. Oak Ridge National Laboratory. ORNL/TM-2011/133.

Solomon, D. I. 1988. Fish Passage through Tidal Energy Barrages. Energy Technical Support Unit, Harwell, England, Contractors Report number ETSU Till 4056.

Tsvetkov, V. I., D. S. Pavlov, and V. K. Nezdolij. 1972. Changes in Hydrostatic Pressure Lethal to the Young of Some Freshwater Fish. *Journal of Ichthyology* 12:307-318.

Tullis, J. P. 1989. *Hydraulics of Pipelines; Pumps, Valves, Cavitation, and Transients*. John Wiley & Sons, Inc., Hoboken, New Jersey.

Turnpenny, A. W. H., M. H. Davis, J. M. Fleming, and J. K. Davies. 1992. *Experimental Studies Relating to the Passage of Fish and Shrimps Through Tidal Power Turbines*. Marine and Freshwater Biology Unit, National Power, Fawley, Southampton, England.

Turnpenny, A. W. H., G. Struthers, and P. Hanson. 2000. *A UK Guide to Intake Fish-Screening Regulations, Policy and Best Practice with Particular Reference to Hydroelectric Power Schemes*. Energy Technology Support Unit, Department of Trade and Industry, Report No. ETSU H/O6/00052/REP.

USACE (U.S. Army Corps of Engineers). 1991. *Revised Compendium on the Success of Passage of Small Fish Through Turbines*. North Pacific Division, Portland, Oregon.

USACE (U.S. Army Corps of Engineers). 1995. *Proceedings of the Turbine Fish Passage Survival Workshop*. U.S. Army Corps of Engineers, Portland District, Portland, Oregon.

Verdant Power, LLC. 2010. *Roosevelt Island Tidal Energy Project, FERC No. P-12611, Final Kinetic Hydropower Pilot License Application*. Submitted by Verdant Power, LLC to the Federal Energy Regulatory Commission.

Vogel, S. 1981. *Life in moving fluids: The physical biology of flow*. Princeton University Press, Princeton, New Jersey.

Von Raben, K. 1957. *Regarding the problem of mutilations of fishes by hydraulic turbines*. Originally published in *Die Wasserwirtschaft* (100):4:97. Fisheries Research Board of Canada Translation Series No. 448 (1964).

The Electric Power Research Institute Inc., (EPRI, www.epri.com) conducts research and development relating to the generation, delivery and use of electricity for the benefit of the public. An independent, nonprofit organization, EPRI brings together its scientists and engineers as well as experts from academia and industry to help address challenges in electricity, including reliability, efficiency, health, safety and the environment. EPRI also provides technology, policy and economic analyses to drive long-range research and development planning, and supports research in emerging technologies. EPRI's members represent more than 90 percent of the electricity generated and delivered in the United States, and international participation extends to 40 countries. EPRI's principal offices and laboratories are located in Palo Alto, Calif.; Charlotte, N.C.; Knoxville, Tenn.; and Lenox, Mass.

Together...Shaping the Future of Electricity

Program:

Waterpower

© 2011 Electric Power Research Institute (EPRI), Inc. All rights reserved. Electric Power Research Institute, EPRI, and TOGETHER...SHAPING THE FUTURE OF ELECTRICITY are registered service marks of the Electric Power Research Institute, Inc.

1024638

Evaluation of Fish Injury and Mortality Associated with Hydrokinetic Turbines

2011 TECHNICAL REPORT

Evaluation of Fish Injury and Mortality Associated with Hydrokinetic Turbines

EPRI Project Manager
P. Jacobson



3420 Hillview Avenue
Palo Alto, CA 94304-1338
USA

PO Box 10412
Palo Alto, CA 94303-0813
USA

800.313.3774
650.855.2121

askepri@epri.com

www.epri.com

1024569

Final Report, November 2011

DISCLAIMER OF WARRANTIES AND LIMITATION OF LIABILITIES

THIS DOCUMENT WAS PREPARED BY THE ORGANIZATION(S) NAMED BELOW AS AN ACCOUNT OF WORK SPONSORED OR COSPONSORED BY THE ELECTRIC POWER RESEARCH INSTITUTE, INC. (EPRI). NEITHER EPRI, ANY MEMBER OF EPRI, ANY COSPONSOR, THE ORGANIZATION(S) BELOW, NOR ANY PERSON ACTING ON BEHALF OF ANY OF THEM:

(A) MAKES ANY WARRANTY OR REPRESENTATION WHATSOEVER, EXPRESS OR IMPLIED, (I) WITH RESPECT TO THE USE OF ANY INFORMATION, APPARATUS, METHOD, PROCESS, OR SIMILAR ITEM DISCLOSED IN THIS DOCUMENT, INCLUDING MERCHANTABILITY AND FITNESS FOR A PARTICULAR PURPOSE, OR (II) THAT SUCH USE DOES NOT INFRINGE ON OR INTERFERE WITH PRIVATELY OWNED RIGHTS, INCLUDING ANY PARTY'S INTELLECTUAL PROPERTY, OR (III) THAT THIS DOCUMENT IS SUITABLE TO ANY PARTICULAR USER'S CIRCUMSTANCE; OR

(B) ASSUMES RESPONSIBILITY FOR ANY DAMAGES OR OTHER LIABILITY WHATSOEVER (INCLUDING ANY CONSEQUENTIAL DAMAGES, EVEN IF EPRI OR ANY EPRI REPRESENTATIVE HAS BEEN ADVISED OF THE POSSIBILITY OF SUCH DAMAGES) RESULTING FROM YOUR SELECTION OR USE OF THIS DOCUMENT OR ANY INFORMATION, APPARATUS, METHOD, PROCESS, OR SIMILAR ITEM DISCLOSED IN THIS DOCUMENT.

REFERENCE HEREIN TO ANY SPECIFIC COMMERCIAL PRODUCT, PROCESS, OR SERVICE BY ITS TRADE NAME, TRADEMARK, MANUFACTURER, OR OTHERWISE, DOES NOT NECESSARILY CONSTITUTE OR IMPLY ITS ENDORSEMENT, RECOMMENDATION, OR FAVORING BY EPRI.

THE FOLLOWING ORGANIZATION, UNDER CONTRACT TO EPRI, PREPARED THIS REPORT:

Alden Research Laboratory, Inc.

NOTE

For further information about EPRI, call the EPRI Customer Assistance Center at 800.313.3774 or e-mail askepri@epri.com.

Electric Power Research Institute, EPRI, and TOGETHER...SHAPING THE FUTURE OF ELECTRICITY are registered service marks of the Electric Power Research Institute, Inc.

Copyright © 2011 Electric Power Research Institute, Inc. All rights reserved.

Acknowledgments

The following organization, under contract to the Electric Power Research Institute (EPRI), prepared this report:

Alden Research Laboratory, Inc.
30 Shrewsbury Street
Holden, MA 01520-1843

Principal Investigators
S. Amaral
N. Perkins
D. Giza
B. McMahan

This report describes research sponsored by EPRI.

This material is based upon work supported by the Department of Energy Water Power Program under Award Number DE-EE0002659. Additional financial support was received from Canada Department of Fisheries & Oceans and Alaska Energy Authority.

We are grateful to Lucid Energy Technologies for providing the Lucid spherical turbine and Glades Hydropower and Dr. Manfred Kuehnle for providing the Welka UPG turbine for the purposes of biological testing. In addition to the Principal Investigators, Alden staff members who provided significant support to the performance and successful completion of this project included Nick Lucia, Jason Muise, Kevin Lamontagne, and Brian Boyce.

Constructive comments by Jocelyn Brown-Saracino and her colleagues, U.S. Department of Energy, and by Glenn Cada, Oak Ridge National Laboratory strengthened this report. We also thank Doug Dixon of EPRI for his leadership of this project during its formative stage.

This publication is a corporate document that should be cited in the literature in the following manner:

Evaluation of Fish Injury and Mortality Associated with Hydrokinetic Turbines.
EPRI, Palo Alto, CA: 2011.
1024569.

Abstract

Considerable efforts have been underway to develop hydrokinetic energy resources in tidal and riverine environments throughout North America. Potential for fish to be injured or killed if they encounter hydrokinetic turbines is an issue of significant interest to resource and regulatory agencies. To address this issue, flume studies were conducted that exposed fish to two hydrokinetic turbine designs to determine injury and survival rates and to assess behavioral reactions and avoidance. Also, a theoretical model developed for predicting strike probability and mortality of fish passing through conventional hydro turbines was adapted for use with hydrokinetic turbines and applied to the two designs evaluated during flume studies. The flume tests were conducted with the Lucid spherical turbine (LST), a Darrieus-type (cross flow) turbine, and the Welka UPG, an axial flow propeller turbine. Survival and injury for selected species and size groups were estimated for each turbine operating at two approach velocities by releasing treatment fish directly upstream and control fish downstream of the operating units. Behavioral observations were recorded with underwater video cameras during survival tests and during separate trials where fish were released farther upstream to allow them greater opportunity to avoid passage through the blade sweep of each turbine. Survival rates for rainbow trout tested with the LST were greater than 98% for both size groups and approach velocities evaluated.

Turbine passage survival rates for rainbow trout and largemouth bass tested with the Welka UPG were greater than 99% for both size groups and velocities evaluated. Injury rates of turbine-exposed fish were low for tests with both turbines and generally comparable to control fish. When adjusted for control data, descaling rates were also low (0.0 to 4.5%). Video observations of the LST demonstrated active avoidance of turbine passage by a large proportion fish despite being released about 25 cm upstream of the turbine blade sweep. Video observations from behavior trials indicated few if any fish pass through the turbines when released farther upstream. The theoretical predictions for the LST indicated that strike mortality would begin to occur at an ambient current velocity of about 1.7 m/s for fish with lengths greater than the thickness of the leading edge of the blades. As current velocities increase above 1.7 m/s, survival was predicted to decrease for fish passing through the LST, but generally remained high (greater than 90%) for fish less than 200 mm in length.

Strike mortality was not predicted to occur during passage through a Welka UPG turbine at ambient current velocities less than about 2.5 m/s. This research effort has resulted in a better understanding of the interactions between fish and hydrokinetic turbines for two general design types (vertical cross-flow and ducted axial flow). However, because the results generally are applicable to the presence of a single turbine, more analysis is needed to assess the potential for multiple units to lead to greater mortality rates or impacts on fish movements and migrations. Additionally, future research should focus on expanding the existing data by developing better estimates of encounter and avoidance probabilities.

Keywords

Fish

Hydrokinetic turbine

Laboratory flume

Strike modeling

Executive Summary

Background and Project Objective

With a pressing need for alternative energy sources in the U.S., Canada and around the world, hydrokinetic turbine technologies have been garnering considerable interest and have recently been experiencing a period of rapid research and development. Many new technologies are being evaluated both in the lab and the field, mainly for engineering and operational proof-of-concept testing, but some studies have begun to examine environmental impacts. As the number of experimental and permanent field applications increase, so will concerns with the effects of installation and operation on aquatic organisms. Although potential impacts to fish and other organisms have been considered (Cada et al. 2007; Wilson et al. 2007), there is little or no information describing the magnitude or importance of these impacts for most of the new turbine technologies.

Consequently, the primary objective of our research was to determine injury and survival rates and behavioral effects for fish approaching and passing downstream of hydrokinetic turbines. This objective was accomplished through the performance of flume studies and theoretical modeling. The flume studies were conducted with two turbine designs, two fish species, two size groups, and two approach velocities, and were designed to estimate injury and survival rates and describe fish behavior in the vicinity of the operating turbines. Also, a theoretical model developed for predicting strike probability and mortality of fish passing through conventional hydro turbines was adapted for use with hydrokinetic turbines and applied to the two designs evaluated during flume studies.

Methods

Biological testing was conducted with two turbine designs, the Lucid spherical turbine (LST) developed by Lucid Energy Technologies and the Welka UPG developed by Current-to-Current. The LST is a Darrieus-type (cross-flow) turbine and the Welka UPG is a horizontal-axis propeller turbine. Survival and injury for selected species and size groups were estimated for each turbine operating at two approach velocities (and corresponding turbine rotational speeds) by releasing treatment fish directly upstream and control fish downstream of the operating units. Treatment fish were forced to pass through the ducted Welka UPG using a containment net enclosing the fish release system and the upstream side of the turbine (i.e., fish could only pass downstream through the turbine with this net in place).

A containment net could not be used with the LST due to the spherical design, which allowed treatment fish the opportunity to avoid entrainment through the blade sweep after exit from the release system at a point of about 25 cm from the upstream face of the turbine (on the blade centerline). Behavioral observations were recorded with underwater video cameras during survival tests and during separate trials where fish were released farther upstream to allow them greater opportunity to avoid passage through the blade sweep of each turbine (within the confined space of the test channel).

Testing with each turbine design was conducted in a large flume with re-circulating flow. To achieve higher velocities for testing with hydrokinetic turbines, temporary walls were installed to constrict the flume width to 2.4 m with a depth of 2.4 m. The hydrokinetic turbines were installed at the downstream end of this narrowed flume section. Tests with both turbines were conducted at approach velocities of 1.5 and 2.1 m/s with two size groups of rainbow trout. Two size groups of largemouth bass were also evaluated with the Welka UPG at the same velocities.

The survival analysis for the two turbine designs involved assessments of immediate (1 hr) and delayed (48 hr) mortality. Injury and scale loss rates were also estimated. Immediate and total (1-hr plus 48-hr) passage survival rates were estimated and statistically analyzed using a maximum likelihood estimation (MLE) model developed for paired release-recapture studies with a single recapture event (Burnham et al. 1987; Skalski 1999). Survival estimates for the LST include fish that were entrained through the blade sweep and fish that avoided turbine passage and moved downstream around the margins of the unit. Because fish evaluated with the Welka UPG could only pass downstream through the turbine, the survival estimates for this design represent direct turbine mortality and do not account for avoidance behaviors that would allow fish to pass safely around the turbine.

Results

Lucid Spherical Turbine

Immediate and total survival rates for rainbow trout tested with the LST were greater than 99% for all sets of test conditions, except for total survival of the larger fish tested at an approach velocity of 2.1 m/s, which was 98.4% (Table ES-1). Immediate survival was not significantly different between the two velocities tested with each size group, or between size groups at each velocity ($P > 0.05$). For the larger fish, total survival was significantly greater at the lower velocity ($P < 0.05$). There were no statistical differences in total survival between size groups at each velocity, or between velocities for the

smaller fish ($P > 0.05$). The percentage of treatment fish recovered without visible external injuries (e.g., bruising, lacerations, and eye damage) exceeded 95% for both size classes and approach velocities evaluated. The percentage of control fish classified as uninjured was similar to treatment fish for both size classes and velocities, indicating that most injuries observed for treatment fish likely resulted from handling and testing procedures and not turbine interactions. When adjusted for control data, the percent of turbine-exposed fish (which either passed around or through the turbine) that were descaled was low, ranging from 0.0 to 4.5%.

Table ES-1

Estimated mean survival rates for rainbow trout exposed to the LST. Survival rates greater than 100% indicate control mortality was greater than treatment mortality.

Approach Velocity (m/s)	Treatment N	Control N	Mean Length (mm)	Immediate Survival (1 hr) \pm 95% CI	Total Survival (1 hr + 48 hr) \pm 95% CI
1.5	456	482	161	100.0 \pm 0.00	99.99 \pm 0.59
2.1	494	497	138	99.43 \pm 1.18	99.03 \pm 1.30
1.5	504	482	250	100.4 \pm 0.80	100.4 \pm 0.80
2.1	501	498	249	99.60 \pm 0.55	98.40 \pm 1.10

A review of underwater videos from a single trial conducted with each velocity and size class demonstrated that avoidance of turbine passage by treatment fish of both size classes was high (82 to 94%) at the two approach velocities evaluated with the LST. Of the fish that were entrained through the rotor, most of the smaller fish passed through the blade sweep tail first, whereas larger fish had a greater tendency to enter the blade sweep sideways at the lower test velocity and head first at the higher velocity. Most entrained fish of both size classes passed through the upstream blade sweep at either the same speed as the flow or slower, at both approach velocities evaluated. The estimated percent of entrained fish struck by a blade during the initial passage through the blade sweep (i.e., on upstream side of turbine) was relatively high for both size groups (about 53 to 91%), and larger fish appeared to be less susceptible to strike at both approach velocities. General video observations from behavioral trials with the LST demonstrated few if any fish interacted with the turbine or were entrained through the blade sweep. Fish typically followed paths along the walls and floor of the test flume. Very few fish were observed entering or interacting with the turbine unit.

Welka UPG Tests

Immediate and total turbine passage survival rates for rainbow trout were 100% for the smaller fish evaluated at both approach velocities and the larger fish tested at the lower velocity (1.5 m/s) (Table ES-2). Immediate and total survival of the larger fish evaluated at the higher velocity (2.1 m/s) were both 99.4%. The only statistical differences detected among the survival rates was between the smaller and larger size groups at an approach velocity of 2.1 m/s, for which the smaller fish had significantly higher immediate and total survival ($P < 0.05$). The percent of uninjured rainbow trout from treatment groups recovered during survival trials with the Welka UPG turbine ranged from about 75 to 94%. For control groups, the rates of uninjured fish were similar to treatment groups, ranging from about 75 to 95%. The overall similarity in treatment and control fish injury rates indicates that most injuries suffered by treatment fish were likely due to handling and testing procedures and not turbine passage. When adjusted for control data, the percent of treatment fish descaled was 0% for all test conditions, except for the smaller fish evaluated at the lower velocity.

Table ES-2

Estimated mean survival rates for rainbow trout (RBT) and largemouth bass (LMB) exposed to the Welka UPG. Survival rates greater than 100% indicate control mortality was greater than treatment mortality.

Species	Approach Velocity (m/s)	Treatment N	Control N	Mean Length (mm)	Immediate Survival (1 hr) \pm 95% CI	Total Survival (1 hr + 48 hr) \pm 95% CI
RBT	1.52	465	467	125	100.87 \pm 1.21	100.87 \pm 1.35
	2.13	504	496	124	101.57 \pm 1.33	101.57 \pm 1.33
	1.52	452	453	230	100.00 \pm 0.00	100.00 \pm 0.00
	2.13	499	499	248	99.40 \pm 0.68	99.40 \pm 0.68
LMB	1.52	499	490	125	100.21 \pm 0.69	99.81 \pm 0.89
	2.13	499	497	124	100.84 \pm 1.27	102.93 \pm 2.94
	1.52	502	490	238	100.00 \pm 0.00	100.00 \pm 0.56
	2.13	498	499	246	100.00 \pm 0.00	99.60 \pm 0.56

Immediate turbine passage survival for largemouth bass tested with the Welka UPG turbine was 100% for both size groups and approach velocities (Table ES-2). Total turbine passage survival was greater than 99% for all test conditions. Statistically significant differences were not detected among any of the test conditions (fish size and approach velocity) evaluated with largemouth bass ($P > 0.05$). The percents of largemouth bass classified as uninjured based on the absence of visible external injuries were 97% or greater for both size groups and approach velocities evaluated. The percent of uninjured control fish was similar, exceeding 94% for all test conditions. Consequently, most injuries observed for treatment fish can be attributed to handling and testing procedures and not turbine passage. After adjusting for control data, the percent of treatment fish classified as descaled was essentially 0% for both size groups and velocities.

General video observations during behavioral testing with the Welka UPG at the 1.5 m/s velocity demonstrated that fish passing downstream towards the turbine units swam or drifted along the floor or walls of the flume. Video observations at the higher velocity were difficult to make due to the presence of entrained air bubbles, which severely limited the ability to see fish approaching the turbine. Most rainbow trout observed approaching the turbine were actively swimming (i.e., tail beating was visible) and facing upstream. Largemouth bass, however, were more likely to drift passively, particularly at the higher channel velocity. Many bass were observed facing upstream but were not actively swimming. In general, video observations from Welka UPG behavioral tests demonstrated that most fish followed flow paths along the walls and floor of the flume. Very few fish were observed passing through or interacting with the turbine.

Theoretical Predictions of Blade Strike

Theoretical models for the probability of blade strike have been developed for use with conventional hydro turbines by several researchers (Von Raben 1957; Franke et al. 1997; Turnpenny et al. 2000; Ploskey and Carlson 2004; Hecker and Allen 2005). Also, some studies have investigated the effects of leading edge blade geometry (shape and thickness), blade speed, and fish orientation on strike injury and survival (Turnpenny et al. 1992; EPRI 2008, 2011b). In concept, the general theoretical model developed for predicting strike probability and mortality for conventional turbines can be applied to hydrokinetic turbines because the mechanics of fish passing through turbines of each application type are, for the most part, the same. However, an important component of strike probability and mortality models that needs to be considered for hydrokinetic turbines is the

velocity of fish as they pass through the blade sweep of a turbine. For conventional hydro turbines, fish velocity is assumed to be that of the inflow velocity, which typically is very high (> 6 m/s). Hydrokinetic turbines operate at lower approach flow velocities (perhaps between 1 to 5 m/s depending on the location and turbine design), and some fish may be able to swim against these velocities to a certain degree. For simplicity and because there is little reliable information on fish speed and behavior approaching various hydrokinetic turbine designs, our application of the strike probability and mortality model to the two turbines evaluated in the flume assumes that fish are traveling at the same velocity as the approach flow. Additionally, it is important to note that theoretical predictions of blade strike do not account for avoidance of the turbine blades by fish, which this study revealed to be significant.

LST Strike Probability and Mortality Predictions

For the LST, strike mortality was predicted to occur at an ambient current velocity of about 1.7 m/s when the strike velocity (relative velocity of fish to blade) is of a sufficient magnitude (greater than about 5 m/s) to cause fatal injuries to fish with lengths that are greater than the thickness of the leading edge of the blades. Strike mortality also increased with fish speed for any given fish length due to corresponding increases in strike velocity. Turbine passage survival for single and double passes through the blade sweep decreased with increases in fish size and ambient current velocity based upon the estimated strike probability and mortality rates. With respect to the effect of fish entry location relative to the vertical plane, passage survival increased as fish move away from the turbine centerline at the same current velocity. Mortality decreases because the turbine diameter decreases above and below the turbine centerline, resulting in a reduced blade speed and therefore a lower strike velocity. As current velocities begin to exceed 1.7 m/s, turbine passage survival was predicted to decrease primarily for larger fish, but generally remained high (greater than 90%) for fish less than 200 mm in length.

The theoretical estimates of turbine passage survival for the LST and the survival estimates calculated from the flume data cannot be directly compared because the flume estimates include fish that avoided turbine passage. However, the flume data indicated survival for all fish, including those that passed through the blade sweep of the LST, was 100% at an approach velocity of 1.5 m/s. This is consistent with the theoretical predictions of turbine passage survival for this approach velocity and supports the conclusion that fish struck by turbine blades at strike velocities less than about 5 m/s will not sustain fatal injuries (strike velocity

on the centerline of the LST is about 4.1 m/s at an approach velocity of 1.5 m/s). Total survival of fish tested in the flume at a velocity of 2.1 m/s was 99.0 and 98.4% for the smaller and larger-sized fish, respectively, both of which are higher estimates of survival than theoretical predictions. The differences between empirical and theoretical data at this velocity reflect the ability of fish to avoid turbine passage in the flume. Experimental and theoretical estimates of survival would be more comparable if the experimental data were sufficient to only include fish entrained through the blade sweep in the calculation of turbine passage survival rates.

Welka UPG Strike Probability and Mortality Predictions

Predicted strike probabilities for fish passing through a Welka UPG turbine increased with fish length and were the same for all ambient current velocities and strike locations along a blade for a given length. Strike probability only varies with fish size because increases in blade speeds with distance from the hub are proportional to the wider spacing between blades, and because fish pass through the turbine more quickly as approach velocity (and blade speed) increase. For fish 600 mm in length and less, strike mortality will not occur during passage through a Welka UPG turbine at ambient current velocities less than about 2.5 m/s because strike velocities will not exceed 5 m/s, which is the approximate upper limit above which fish mortality will begin to occur [depending on the ratio of fish length to blade thickness; EPRI (2008)]. Consequently, estimated turbine passage survival will be 100% for fish that pass through a Welka turbine over the entire blade length at an ambient current of 2.5 m/s or less. Also, the theoretical estimates are consistent with the experimental results from flume testing (mean survival rates ranging from 99.4 to 100%). Note that the experimental setup forced all test fish through the ducted Welka UPG turbine, thereby precluding turbine avoidance by the fish.

Conclusions

The information and data developed from this research effort has resulted in a better understanding of the interactions between fish and hydrokinetic turbines for two general design types (vertical cross-flow and ducted axial flow). However, the ability to apply the study results to other turbines will depend, in part, on differences in design and operation (e.g., blade shape and spacing, number of blades, turbine diameter, and rotational speeds) compared to the two turbines that were evaluated as part of the current study. Regardless of turbine differences, the observations of fish behavior, particularly avoidance at a very

close distance to moving blades, provide strong evidence as to how fish are likely to react when approaching a wide range of hydrokinetic turbine designs in the field.

Little, if any, mortality, injury, and scale loss are expected to occur for fish encountering an LST in an open water environment (i.e., riverine or tidal). Similarly, fish entrained through a Welka UPG turbine will suffer little or no injury and mortality over the likely range of operating conditions. The theoretical predictions of turbine passage survival for the LST differed from the lab results, but this was due to the ability of fish to avoid passage through the turbine during flume testing, whereas the strike probability and mortality model is only applied to fish that pass through the blade sweep. This highlights the limitations of theoretical strike predictions that do not account for avoidance and evasive behavior by fish. For the Welka UPG, turbine passage survival predictions were consistent with the experimental results from flume testing, suggesting that a predictive model could be used to assess turbine passage survival rates at future field installations for fish that do not avoid the turbines.

The evidence that a large proportion of fish will avoid passage through hydrokinetic turbines and that overall survival rates will be high for fish that encounter turbines in open water settings is growing. In addition to the observations from the Alden tests, results from flume testing at Conte Anadromous Fish Research Laboratory with a Darrieus turbine (cross-flow with straight vertical blades) indicated that Atlantic salmon smolts may avoid turbine passage and that downstream passage survival is likely to be high (EPRI 2011c). In a recent field study, turbine passage survival for several freshwater species with mean lengths ranging from about 100 to 700 mm (about 4 to 30 inches) was estimated to be 99% for a ducted, axial-flow hydrokinetic turbine (NAI 2009). Individually and collectively, the results from laboratory and field studies suggest that the mortality of juvenile and adult fish passing through hydrokinetic turbines of this design, and perhaps others, will be below levels of concern. However, because the results generally are applicable to the presence of a single turbine, more analysis is needed to assess the potential for multiple units to lead to greater mortality rates or impacts on fish movements and migrations. Additionally, future research should focus on expanding the existing data by developing better estimates of encounter and avoidance probabilities. Encounter rates could be developed from field monitoring of fish abundance and movements or based on the proportion of channel flow that passes through a turbine (or the cross-sectional area of a channel that a turbine's blade sweep occupies).

Avoidance probabilities for fish that encounter a turbine could also be derived from field monitoring or additional flume testing. These data can then be combined with laboratory or theory-based estimates of turbine passage survival to develop a more comprehensive model that incorporates site-specific hydraulic and environmental conditions to estimate total expected fish losses for single and multiple unit installations. The use of computational fluid dynamics (CFD) modeling may also play an important role in such analyses, particularly if fish behavior can be incorporated.

Table of Contents

Section 1: Introduction	1-1
Section 2: Biological Evaluation – Test Methods	2-1
Design and Operation of Hydrokinetic Turbines Selected for Fish Testing	2-1
Lucid Spherical Turbine	2-1
Welka Underwater Power Generator (UPG) Turbine	2-3
Test Facility Design and Operation	2-4
Test Species and Fish Holding Facility Design and Operation	2-9
Experimental Design and Test Procedures	2-10
Survival Testing	2-12
Behavioral Testing	2-14
Survival Data Analysis	2-15
Velocity Measurements	2-17
Section 3: Biological Evaluation – Results	3-1
Lucid Spherical Turbine	3-1
Survival Testing	3-1
Behavioral Tests	3-12
Welka UPG Turbine	3-14
Survival Tests	3-14
Behavioral Tests	3-25
Section 4: Theoretical Predictions of Blade Strike Probability and Mortality	4-1
Strike Probability and Mortality Model	4-3
Application of Strike Model to Lucid Spherical Turbine	4-4
Model Parameters and Assumptions	4-4
Turbine Passage Survival Estimates	4-7
Application of Strike Model to the Welka UPG Turbine	4-14
Model Parameters and Assumptions	4-14
Turbine Passage Survival Estimates	4-16
Section 5: Conclusions and Discussion	5-1
Section 6: Literature Cited	6-1

List of Figures

Figure 2-1 Lucid spherical turbine installed in Alden’s test flume for fish testing	2-2
Figure 2-2 Rotational speed versus approach flow velocity for the Lucid spherical turbine	2-2
Figure 2-3 Tangential blade velocity (at blade midpoint) versus approach flow velocity for the Lucid spherical turbine	2-3
Figure 2-4 Downstream (A) and upstream (B) views of the Welka UPG turbine installed in Alden’s large flume test facility.....	2-4
Figure 2-5 Alden’s large flume fish testing facility configured for the biological evaluation of hydrokinetic turbines	2-5
Figure 2-6 Downstream View (A) and Upstream View (B) of Alden’s large flume fish testing facility configured for the biological evaluation of hydrokinetic turbines with constricting walls installed	2-6
Figure 2-7 Downstream view of the test fish release system configured for survival testing with the Lucid turbine	2-8
Figure 2-8 Downstream view (A) and top view (B) of the Welka UPG turbine configured with containment netting to prevent fish from passing downstream outside the turbine during survival testing.	2-9
Figure 2-9 Diagram showing the body locations assessed for percent scale loss on all evaluated fish	2-13
Figure 2-10 Downstream view of fish release system location used for behavioral trials	2-17
Figure 2-11 Velocity profile 3x3 grid, displaying each velocity measurement point	2-18

Figure 2-12 Velocity measurements recorded with a Swoffer meter directly upstream of the test turbine location. Measurements could not be recorded at the deepest transect (3) at the higher target velocity (2.1 m/s) because the meter could not be held stable for accurate readings.2-18

Figure 3-1 Immediate (1 hr) and total (1 hr + 48 hr) survival rates (\pm 95% CI) for rainbow trout tested with the LST. Non-overlapping confidence intervals indicate statistically significant differences between survival estimates.3-4

Figure 3-2 Video observations (top view) demonstrating avoidance of the LST during survival testing with of 125 mm (A) and 250-mm (B) rainbow trout avoidance at an approach velocity of 1.5 m/s. Fish of both size groups were observed moving to the sides of the turbine and the larger trout typically maintained position between the exit of the release tube and the upstream face of the turbine blade sweep (B) for several minutes before passing downstream through or around the turbine.3-10

Figure 3-3 Side view from underwater camera showing 250 mm rainbow trout maintaining position directly upstream of the turbine blade sweep and a fish passing through turbine during survival testing3-11

Figure 3-4 Immediate (1 hr) and total (1 hr + 48 hr) survival rates (\pm 95% CI) for rainbow trout tested with the Welka UPG. Non-overlapping confidence intervals indicate statistical differences between survival estimates.3-17

Figure 3-5 Immediate (1 hr) and total (1 hr + 48 hr) survival rates (\pm 95% CI) for largemouth bass tested with the Welka UPG. Non-overlapping confidence intervals indicate statistically significant differences between survival estimates.3-23

Figure 3-6 Side camera view (A) showing a fish being struck by a blade and top view (B) showing fish swimming immediately upstream of the blade sweep during testing at an approach velocity of 1.5 m/s.....3-27

Figure 4-1 Absolute inflow, axial (or radial) component and relative velocity to blade. The parameter Δs is the incremental blade motion in the time fish move through the leading edge circumference.4-4

Figure 4-2 Schematic plan view of fish approach locations and corresponding velocity vectors for the Lucid spherical turbine4-5

Figure 4-3 Schematic elevation view of fish approach locations and corresponding velocity vectors for the Lucid hydrokinetic turbine.....4-6

Figure 4-4 Strike probability versus fish length for a single pass through the blade sweep of a Lucid spherical turbine with fish approaching the turbine at the same speed as the flow. For any given fish length, strike probability is the same for all flow approach velocities and for all strike locations along a blade (i.e., strike probability at the mid and quarter blade points will be the same).4-9

Figure 4-5 Predicted strike mortality (i.e., probability a fish is killed if struck by a blade) for fish passing through the LST blade sweep once at three approach velocities (i.e., fish speed equals flow speed) and two vertical locations (mid and quarter blade).4-12

Figure 4-6 Predicted turbine passage survival (combining strike probability and strike mortality) for fish up to 600 mm in length passing through the LST at three approach velocities (i.e., fish speed equals flow speed) and two vertical locations (mid and quarter blade). Survival rates account for fish passing through the blade sweep twice.4-13

Figure 4-7 Turbine passage survival rates (combining strike probability and strike mortality) versus ambient current velocity for different lengths of fish. These estimates are based on the assumption that fish are approaching a turbine at the same speed as the ambient current and they pass through the blade sweep twice.4-14

Figure 4-8 Velocity vector triangle for the Welka UPG hydrokinetic turbine.....4-16

List of Tables

Table 2-1 Test conditions evaluated with each turbine. Test species included rainbow trout (RBT) and largemouth bass (LMB). Five replicate trials were conducted with each set of test conditions for the survival evaluation and three trials were conducted for the behavioral evaluation. Approximately 100 treatment and 100 control fish were released per replicate for survival trials; 50 fish per replicate were released for behavioral trials (no controls).	2-11
Table 3-1 Summary of fish release, recovery, and mortality data for rainbow trout tested with the LST during the survival evaluation.	3-2
Table 3-2 Survival estimates (adjusted for control mortality) for rainbow trout evaluated with the LST. Survival rates above 100% resulted when control mortality was greater than treatment mortality.	3-3
Table 3-3 Percent of rainbow trout recovered during LST survival testing that were observed with external injuries.	3-5
Table 3-4 Percent of rainbow trout classified as descaled during survival tests with the LST	3-8
Table 3-5 Summary of fish avoidance and entrainment data from video observations recorded during rainbow trout survival tests with the LST. Video observations were recorded for a single trial conducted with each velocity and fish size group by two observers. The avoidance and entrainment data recorded by each observer were averaged. The observations are based on approximately 100 fish being released for each trial.	3-9
Table 3-6 Summary of release and recapture for behavioral tests with conducted with rainbow trout and the LST	3-13
Table 3-7 Summary of fish release, recovery, and mortality data for rainbow trout tested with the Welka UPG turbine during the survival evaluation	3-15

Table 3-8 Turbine passage survival estimates (adjusted for control mortality) for rainbow trout evaluated with the Welka UPG turbine. Survival rates above 100% resulted when control mortality was greater than treatment mortality.....	3-16
Table 3-9 Percent of rainbow trout recovered during Welka UPG turbine survival testing that were observed with external injuries	3-19
Table 3-10 Percent of rainbow trout classified as descaled during survival tests with Welka UPG turbine	3-20
Table 3-11 Summary of fish release, recovery, and mortality data for largemouth bass tested with the Welka UPG turbine during the survival evaluation	3-21
Table 3-12 Turbine passage survival estimates (adjusted for control mortality) for largemouth bass evaluated with the Welka UPG turbine. Survival rates above 100% resulted when control mortality was greater than treatment mortality.....	3-22
Table 3-13 Percent of largemouth bass recovered during Welka UPG turbine survival testing that were observed with external injuries	3-24
Table 3-14 Percent of largemouth bass recovered during Welka turbine trials that were observed with descaling	3-26
Table 3-15 Summary of release and recapture data for behavioral tests with largemouth bass (LMB) and rainbow trout (RBT) and the Welka UPG turbine	3-28
Table 4-1 Summary of blade strike probability, predicted strike mortality, and predicted turbine passage survival for a Lucid spherical turbine operated at three current velocities with fish passing through at the blade midpoint. Turbine passage survival is presented for fish passing through the blade sweep once and twice (i.e., entry into and exit from turbine).	4-10

Table 4-2 Summary of blade strike probability, predicted strike mortality, and predicted passage survival for a Lucid spherical turbine operated at three current velocities with fish passing through the blade quarter point. Turbine passage survival is presented for fish passing through the blade sweep once and twice (i.e., entry into and exit from turbine).4-11

Table 4-3 Estimated blade strike probability and predicted survival rates for fish of various sizes passing through the Welka UPG turbine at two ambient current velocities and blade locations.....4-17



Section 1: Introduction

With growing demand for alternative energy sources in the U.S. and elsewhere, marine and hydrokinetic power generation technologies have been garnering considerable interest and have recently been experiencing a period of rapid research and development. Many new technologies are being evaluated both in the laboratory and the field, mainly for engineering and operational proof-of-concept testing; however, some studies have begun to examine environmental impacts (RESOLVE 2006; DTA 2006; Wilson et al. 2007; DOE 2009; NAI 2009). As the number of experimental and permanent field applications increase, so will concerns with the effects of installation and operation on aquatic organisms. Although potential impacts to fish and other organisms have been identified and considered (Cada et al. 2007; Wilson et al. 2007), there is little or no information describing the relative magnitude or importance of these impacts for many of the new turbine technologies. A primary issue of concern for regulatory and resource agencies is how the operation of hydrokinetic turbines installed in flowing water environments will affect or impact local and migratory fish populations. In particular, what is the potential for fish to be killed or injured if they pass through one or more turbines, and what is the potential for operating turbines to disrupt or block fish movements and migrations?

Environmental impacts associated with hydrokinetic turbines will depend primarily on turbine type and design and the characteristics of the environment in which the turbines are deployed (e.g., river, tidal, or ocean). Direct impacts potentially include fish injury and mortality due to blade strike and hydraulic conditions that can damage or disorient fish (Cada et al. 2007; Wilson et al. 2007). Potential indirect impacts are related to disruptions in local movements and migrations, and access to feeding, spawning, and nursery habitats in the vicinity of turbine installations. The size and numbers of turbines installed may influence the magnitude of direct and indirect impacts. The potential for injury and mortality of fish that pass through operating hydrokinetic turbines is a leading concern, particularly if installations are located in rivers with diadromous fish populations (i.e., species that undergo obligatory upstream and downstream migrations that occur during specific times of the year). Similar to rivers with numerous hydro dams, local fish populations may encounter multiple turbines and thereby experience the cumulative effects of passage at multiple turbines at a single project and at multiple projects on a given river. Fish injury and mortality may also be an important issue for hydrokinetic turbines deployed in tidal and ocean environments if the turbines are located in areas where large numbers of fish encounter and pass through the turbines. The location of turbines will also be an important factor with respect to the potential for disruption of fish movements.

The Electric Power Research Institute (EPRI) was awarded a grant by the U.S. Department of Energy (DOE) to develop information and data that can be used to assess the potential for any given project to adversely affect fish by completing the following studies:

- Review of existing information on injury mechanisms associated with fish passage through conventional hydro turbines and the relevance and applicability of this information to fish passage through hydrokinetic turbines.
- Flume testing with up to three turbine designs and several species and size classes of fish to estimate direct injury and survival rates and describe fish behavior in the vicinity of operating turbines.¹
- Development of theoretical models for the probability of blade strike and mortality for various hydrokinetic turbine designs

EPRI contracted Alden Research Laboratory, Inc. (Alden) to conduct these studies. This report describes the study approach and results for the application of theoretical blade strike models to hydrokinetic turbines and the evaluation of fish interactions with two turbine designs installed in Alden's large flume test facility. The review of existing information on fish passage through conventional hydro turbines as it relates to hydrokinetic turbines is provided in a separate report submitted by EPRI to the DOE (EPRI 2011a).

The primary goal of the studies described herein was to provide developers and resource and regulatory agencies with data to better assess the potential impacts of hydrokinetic turbines on local and migratory fish populations. Achieving this goal will facilitate licensing of proposed hydrokinetic energy projects in the U.S. The blade strike probability and mortality models and the laboratory data that are presented likely will reduce the need and cost for expensive and logistically difficult field studies and serve as baselines for the assessment of fish impacts of any turbine design. However, because laboratory evaluations cannot fully replicate what will occur in the field, some level of in-water testing may be needed for future installations. Also, future studies can build on the results of the studies presented in this report to improve and expand the dataset, reduce uncertainties, and increase the confidence with which resource and regulatory agencies can evaluate the potential for adverse environmental impacts. The lab and desktop studies should contribute to the understanding of environmental impacts to help reduce uncertainty and risk in decision-making for permitting of hydrokinetic turbines.

¹ Limited availability of turbine designs suitable for flume testing and the final scope of work for this project resulted in testing of two designs at Alden. A third turbine design was tested at the USGS Conte Anadromous Fish Research Laboratory, which is discussed in a separate report.



Section 2: Biological Evaluation – Test Methods

Biological testing was conducted with two turbine designs, a spherical cross-flow turbine developed by Lucid Energy Technologies and a horizontal-axis propeller turbine developed by Current-to-Current. Fish survival was estimated for each turbine and selected operating conditions (approach velocity and corresponding turbine rotational speed) by releasing test fish directly upstream and control fish downstream of the operating units. Survival estimates account for direct injury and mortality, but do not address indirect effects (e.g., higher rates of disease and predation) related to sub-lethal injuries. Behavioral observations were recorded with underwater video cameras during survival tests and during separate trials where fish were released farther upstream to allow them greater opportunity to avoid passage through the blade sweep of each turbine (within the confined space of the test channel). Detailed information on the turbines, test facility, and experimental design is provided below.

Design and Operation of Hydrokinetic Turbines Selected for Fish Testing

Lucid Spherical Turbine

The Lucid spherical turbine (LST) is a cross-flow unit designed for installation in pipes or conduits (Northwest PowerPipe™) or in free-flowing unbounded systems (i.e., rivers and tidal areas). The LST used for fish testing was a full-scale model with a diameter of 1.14 m (45 inches), a height of 0.97 m (38 inches), and four blades (Figure 2-5). The blades are curved from the top mounting plate to the bottom plate, but they do not twist like the blades of a Gorlov helical turbine. The 1.14-m diameter model is expected to operate at current velocities ranging from about 1.5 to 3.0 m/s (5 to 10 ft/s). At these flow velocities, the rotational speed of the LST ranges from 64 to 127 rpm (Figure 2-2) and tangential blade velocities at the blade midpoint range from 3.8 to 7.6 m/s (Figure 2-3).



Figure 2-1
Lucid spherical turbine installed in Alden's test flume for fish testing

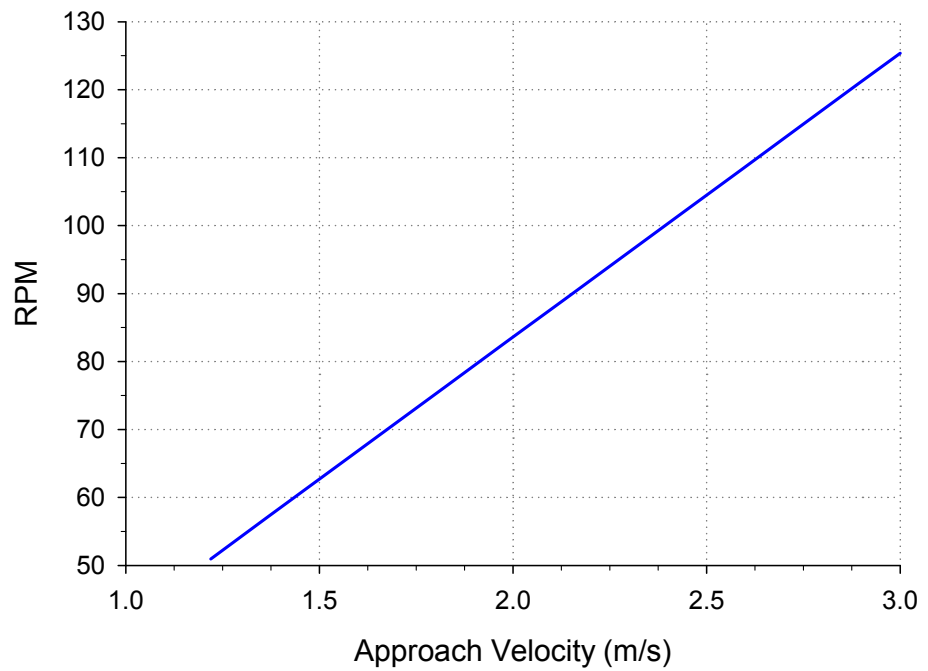

Figure 2-2
Rotational speed versus approach flow velocity for the Lucid spherical turbine

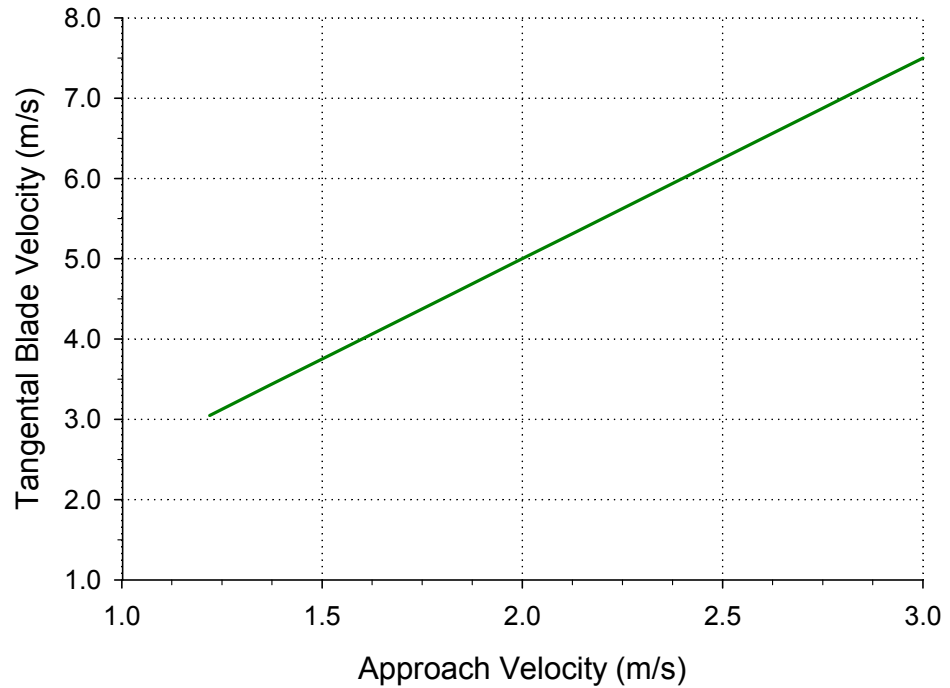

Figure 2-3
Tangential blade velocity (at blade midpoint) versus approach flow velocity for the Lucid spherical turbine

Welka Underwater Power Generator (UPG) Turbine

The Welka Underwater Power Generator turbine (UPG) is a ducted horizontal-axis turbine design with four blades. The unit provided for fish testing, which has been previously tested in Alden’s large flume facility for operational performance, had a diameter of 60 inches (Figure 2-4). This unit is designed to operate at current velocities of about 0.6 to 2.1 m/s (2 to 7 ft/s) with rotational speeds of 15 to 35 rpm. For the minimum and maximum current velocities, blade speeds range from 0.6 to 1.4 m/s at the blade midpoint and 1.2 to 2.8 m/s at the tip. Corresponding strike velocities (i.e., relative velocity of fish to blade) for fish traveling at the speed of the approach flow range from 1.6 to 2.5 m/s at the blade midpoint and 1.9 to 3.5 m/s at the tip. Strike velocities will be higher for fish passing through the blade sweep faster than the approach flow, and lower for fish passing at slower speeds.



*Figure 2-4
Downstream (A) and upstream (B) views of the Welka UPG turbine installed in
Alden's large flume test facility*

Test Facility Design and Operation

Biological testing of each hydrokinetic turbine was conducted in Alden's large flume fish testing facility (Figure 2-5). The test flume has a concrete floor about 3 m (10 ft) below the top of the side walls. Located beneath this floor at the downstream end of the flume are two 1.7-m diameter (66 inch) bow-thrusters (400 hp each) capable of pumping up to 14.2 m³/s (500 cfs) through the test channel with the assistance of turning vanes at both ends (i.e., flume water is circulated vertically at either end of the flume). The length of the test area is approximately 24.4 m (80 ft) with a total width of 6.1 m (20 ft) and maximum water depth of about 2.4 m (8 ft). To achieve higher velocities for testing with hydrokinetic turbines, temporary walls were installed to constrict the flume width to 2.4 m (8 ft) (Figure 2-6). The hydrokinetic turbines were installed at the downstream end of the narrowed flume section. To minimize flow separation and turbulence, the entrance to the narrowed section had rounded walls. The flume is equipped with a side-mounted Acoustic Doppler Current Profiler (ACDP) to measure water velocities and determine flow rates to establish specific experimental treatments.

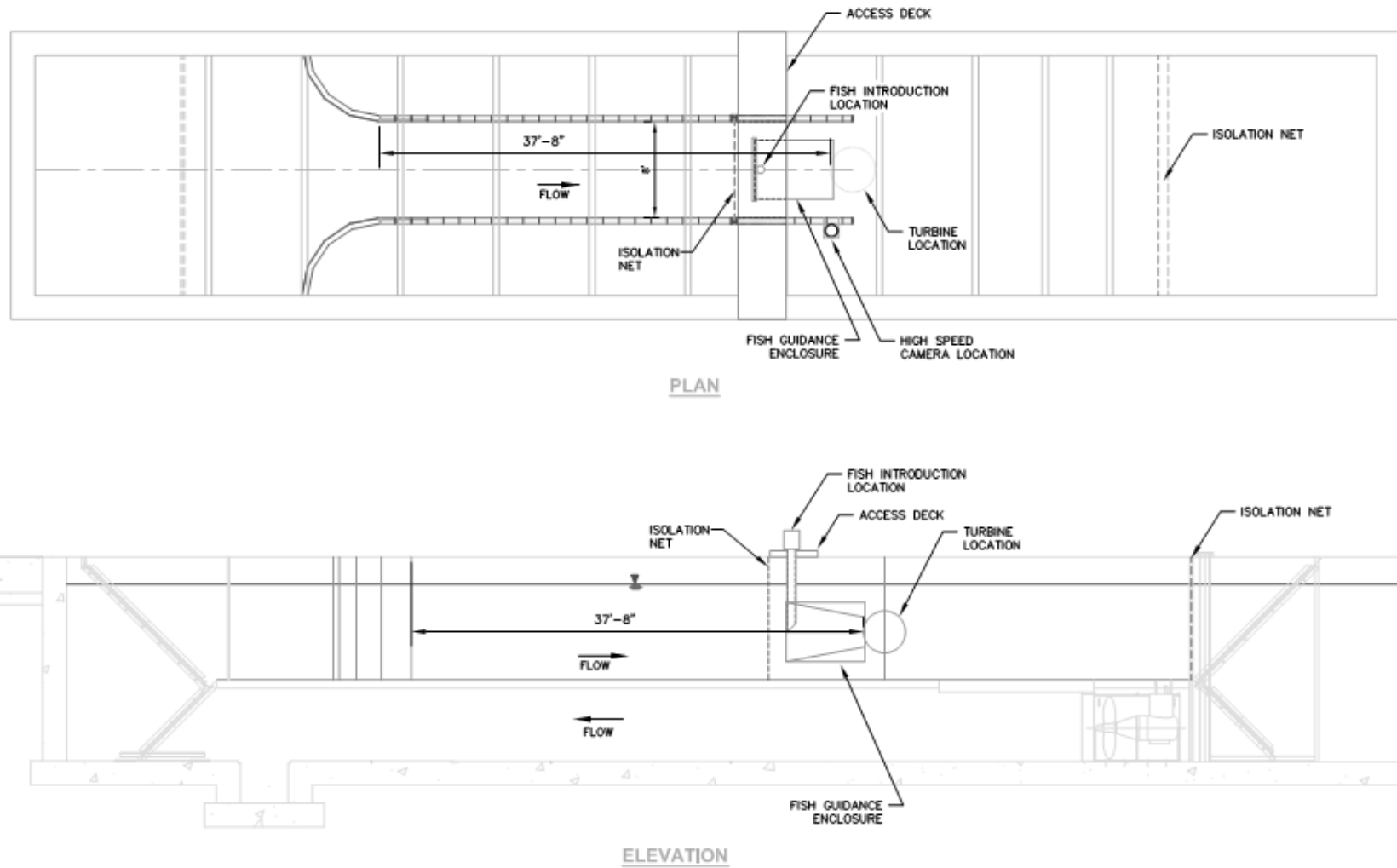

Figure 2-5
 Alden's large flume fish testing facility configured for the biological evaluation of hydrokinetic turbines



Figure 2-6
Downstream View (A) and Upstream View (B) of Alden's large flume fish testing facility configured for the biological evaluation of hydrokinetic turbines with constricting walls installed

Flume water quality was maintained using a canister filter system and ultraviolet (UV) sterilization installed on a side loop that received flume water through a 15-hp pump. Filter bags with 10-micron mesh were used in the canister filter to remove particulates and solids in order to maintain good water clarity. The UV sterilizer was used to reduce the presence of pathogens. A 100-ton chiller was used when needed to maintain water temperatures at specified levels for the species selected for testing (rainbow trout and largemouth bass).

Fish were released into the flume for each test through a vertical 20.3-cm (8-inch) diameter pipe connected to a 25.4-cm (10-inch) diameter horizontal injector tube located just upstream of each turbine (Figure 2-7). The vertical pipe was covered with an aluminum shroud elongated in the upstream and downstream directions to reduce head loss associated with the obstruction of flow. The upstream end of the horizontal injector tube was equipped with 2.2 cm (0.875-inch) knotless mesh to prevent test fish from exiting the injection system in the upstream direction (i.e., away from the turbines). During survival tests the front of the horizontal injector was approximately 10- 12 inches from the upstream face of the LST blade sweep and the shroud of the ducted Welka UPG. For survival tests with the Welka turbine, a containment net was used to prevent fish from swimming away from the turbine (either upstream or outside the turbine duct), thereby forcing them to pass downstream through the turbine blade sweep after leaving the injector tube (Figure 2-8). The containment netting was constructed of 2.2 cm (0.875-inch) knotless mesh. Due to the spherical shape of the LST and a lack of any type of duct structure, a containment net could not be used to restrict downstream movement of fish through the turbine's blade sweep. Therefore, test fish had the ability to avoid passage through the LST during survival testing by moving laterally or up or down in the water column when they exited from the injector tube. For behavioral tests, the injection system was moved farther upstream (and the containment netting was removed for tests with the Welka UPG) to allow fish the opportunity to avoid entrainment through the blade sweep of each turbine. Thus, the goal of these tests was to monitor behavioral reactions as fish approached each turbine and to estimate percent avoidance and entrainment. However, video quality was not sufficient to view all areas around the two turbines, preventing detection of some fish as they passed downstream. This was particularly true for tests at the higher velocity (2.1 m/s), during which air entrainment was significant and resulted in limited visibility.



Figure 2-7
Downstream view of the test fish release system configured for survival testing with the Lucid turbine

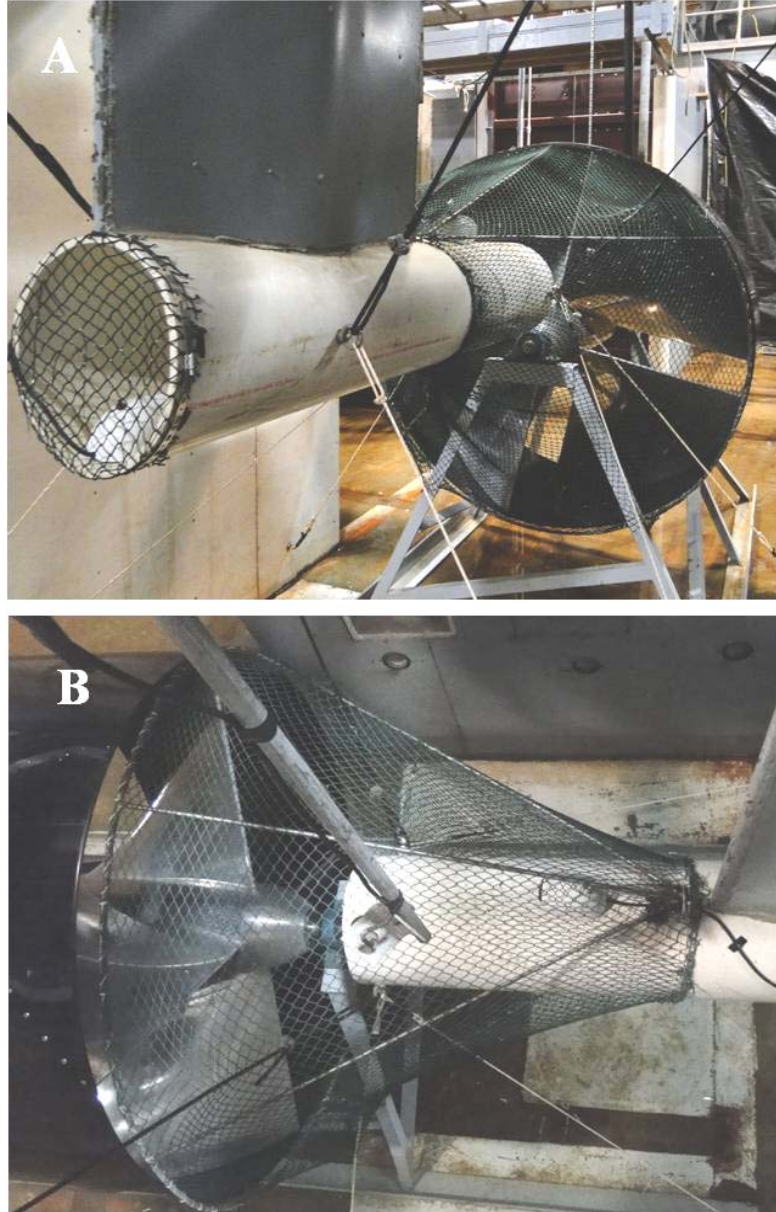

*Figure 2-8
Downstream view (A) and top view (B) of the Welka UPG turbine configured with containment netting to prevent fish from passing downstream outside the turbine during survival testing.*

Test Species and Fish Holding Facility Design and Operation

Two fish species, rainbow trout and largemouth bass, were selected for testing based on availability from commercial suppliers and similarity to a variety of species that are likely to encounter hydrokinetic turbines in riverine environments. Rainbow trout were acquired from Hy-On-A-Hill Trout Farm located in Plainsfield, New Hampshire, and largemouth bass were acquired from Hickling's Fish Farm Inc. located in Edmeston, New York. Both sources are

certified disease-free facilities, ensuring that test fish were of high quality and in good health. Target size classes selected for testing with both species included length ranges of about 100 to 150 mm (4 to 6 inches) and 225 to 275 mm (9 to 11 inches). These ranges were considered sufficient to test for differences in survival associated with fish length, are representative of the sizes of many fish species and life stages that will encounter hydrokinetic turbines in riverine and tidal environments, are readily available from commercial sources, and can be held, handled, and tested in a laboratory environment without the need for special procedures, holding facilities, or testing equipment.

All fish were held prior to testing and during 48-hr post test observation periods in a re-circulating fish holding system located in a building adjacent to the test flume. The holding facility has seven 420-gallon circular tanks and eighteen 235-gallon circular tanks. Each holding tank is supplied with a continuous flow of about 15 to 26 l/min (4 to 7 gpm). Solid waste products and particulates are removed with coarse and fine micron bag filters. A bio-filter system was used to remove ammonia and activated carbon was used to remove other impurities. An ultraviolet sterilization filter was used to minimize the presence of pathogens. The holding system also has a chiller and submersible heaters to maintain optimum temperatures throughout the year for the species being held. Temperature, dissolved oxygen, and pH were monitored on a daily basis, and ammonia was measured several times per week. Fish physiology and behavior was visually assessed daily to screen for external signs of disease, fungus, or infection by parasites. Alarm systems with an auto-dialer were operational 24/7 and in the event of a facility malfunction (e.g., pump failure, power outage, low water levels), Alden staff was notified and responded within the hour.

Experimental Design and Test Procedures

Test conditions for the Welka UPG turbine included two species, two size groups, and two approach velocities and corresponding turbine rotational speeds (Table 2-1). Two size groups and two approach velocities were evaluated with the spherical turbine, but tests were only conducted with rainbow trout (Table 2-1). The two flow velocities selected for testing were sufficient to assess the potential effects of this parameter on turbine passage survival. Also, the lower flow velocity (1.5 m/s) is about the speed at which the test turbines begin operating, and the higher speed (2.1 m/s) is the maximum velocity that could be attained with the flume configuration used for testing. Two test types (survival and behavioral) were conducted for each turbine design. Survival testing involved releasing fish immediately upstream of each operating turbine in attempts to force fish to pass through the blade sweep, whereas behavioral trials with fish released farther upstream of the turbine focused on whether fish would actively avoid passing through the blade sweep and downstream on the outside of the turbine.

Table 2-1

Test conditions evaluated with each turbine. Test species included rainbow trout (RBT) and largemouth bass (LMB). Five replicate trials were conducted with each set of test conditions for the survival evaluation and three trials were conducted for the behavioral evaluation. Approximately 100 treatment and 100 control fish were released per replicate for survival trials; 50 fish per replicate were released for behavioral trials (no controls).

Turbine	Species	Size Group (mm)	Test Type	Velocity (m/s)	Replicate Trials
Welka UPG	RBT	125	Survival	1.5	5
				2.1	5
		Behavioral	1.5	3	
			2.1	3	
		250	Survival	1.5	5
				2.1	5
	Behavioral	1.5	3		
		2.1	3		
	LMB	125	Survival	1.5	5
				2.1	5
		Behavioral	1.5	3	
			2.1	3	
250		Survival	1.5	5	
			2.1	5	
Behavioral	1.5	3			
	2.1	3			
LST	RBT	125	Survival	1.5	5
				2.1	5
		Behavioral	1.5	3	
			2.1	3	
		250	Survival	1.5	5
				2.1	5
Behavioral	1.5	3			
	2.1	3			

Survival Testing

Survival tests were conducted to estimate blade strike injury and mortality associated with fish passage through each turbine (assuming little or no damage to fish would occur due to other injury mechanisms, such as hydraulic shear or pressure changes). To estimate survival, groups of marked fish were released immediately upstream (treatment) and downstream (control) of the test turbines while the turbines were operating at the selected approach flow velocities and rotational speeds. Treatment and control groups were handled and released in the same manner, with the only difference being release location and the subsequent exposure of treatment fish to the operating turbines. The use of controls allowed for injury and mortality associated with handling and test procedures (e.g., marking, release, collection) to be determined and distinguished from that of exposure to the turbines. Target sample sizes were 100 treatment and 100 control fish per trial and five replicate trials were conducted per test condition (species, size class, channel velocity). Based on a similar laboratory survival study conducted with the fish-friendly Alden turbine (Cook et al. 2003), these sample sizes and level of replication were considered adequate for achieving 95% confidence intervals that were within $\pm 5\%$ of survival estimates.

All treatment and control fish were marked with biologically inert, encapsulated photonic dyes 24 hours or more prior to testing using a New West POW'R-Ject marking gun. This marking system uses compressed CO₂ to inject the photonic dye at the base of or into individual fins. Four dye colors and four fin locations were used to provide 16 unique marks. Unique marking of release groups allowed treatment and control fish to be released and recovered simultaneously and facilitated assignment of the few fish not captured immediately following a test to the appropriate prior test (most released fish were recovered at the completion of each trial, but some individuals were recovered during a later trial). Of the 11,716 treatment and control fish released during survival testing, only 90 (0.8%) did not have a discernable mark when recovered. Following marking, each marked group (treatment or control) was placed into a separate recovery tank until the day of testing.

For each trial, treatment and control groups were placed into separate mobile holding tanks and moved to the test flume area after the fin mark and total number had been confirmed. Each group was released into the flume once the flume channel velocity and turbine rotational speed were established. Treatment fish were transferred from the mobile tank into the fish injection system from which they entered the flume immediately upstream of the operating turbines. Control fish were transferred out of the mobile tank and released directly into the test flume at the surface immediately downstream of the turbines and within the channel flow to the best extent possible.

After introduction, treatment fish movement and passage through the turbine was monitored and recorded with underwater video cameras. Individual tests were terminated after all treatment fish had passed the turbine or approximately ten minutes after introduction. At the completion of each test trial, an isolation screen was lowered immediately upstream of the release location to preclude fish

from moving up or downstream of the turbine. The test flume was turned off at this time and the water level was lowered to allow for personnel to enter the flume. Fish were then crowded with a seine net for recovery, counting, and transfer to the holding facility. Live fish were placed in holding tank and held for 48 hours to monitor for delayed mortality. Treatment and control fish from a given trial remained together in the same post-test holding tank from the time of collection until the end of the delayed mortality holding period.

Survival, injury, and scale loss evaluations were conducted on all recovered fish to enumerate immediate and delayed mortalities, external injuries, and percent scale loss. Immediate mortalities were classified as any fish that died within one hour from the completion of a test. Twenty-four hour mortalities were classified as any fish that died after one hour and up to 24 hours of the test completion. Forty-eight hour mortalities were classified as any fish that died between 24 hours and 48 hours. Injury and scale loss evaluations were conducted at the end of the 48 hour post-test holding period for live fish and at the time of recovery for immediate and delayed mortalities. External injuries were recorded as bruising/hemorrhaging, lacerations, severed body, eye damage, and descaled. Using methods similar to those reported by Neitzel et al. (1985) and Basham et al. (1982), percent scale loss (< 3%, 3 – 20%, 21 – 40%, and > 40%) was recorded for each of three locations along the length of the body (Figure 2-9; if greater than 20% scale loss occurred in two or more locations, then a fish was classified as descaled. During the injury evaluation, each fish was also inspected for fin mark location and color to determine release group and test number, and measured for fork length to the nearest mm.

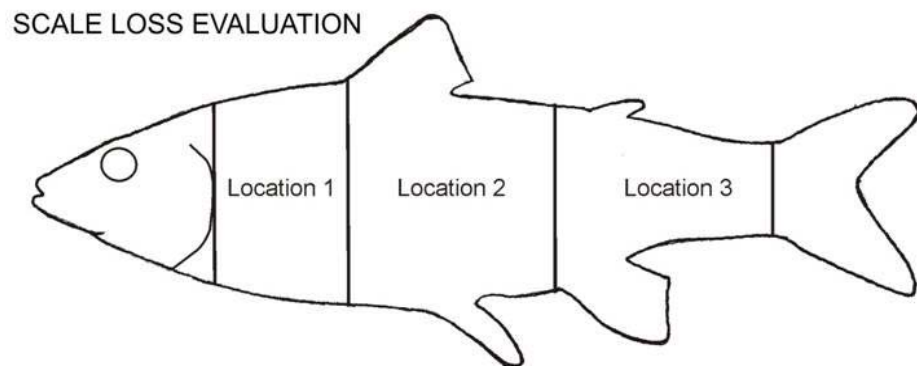

*Figure 2-9
Diagram showing the body locations assessed for percent scale loss on all evaluated fish*

As previously stated, due to the spherical shape of the LST, a containment net could not be used to force fish to pass through the turbine. Therefore, in an effort to estimate how many fish avoided passage through the LST or were entrained, underwater videos of several trials were reviewed to determine percent avoidance and entrainment, orientation of entrained fish, and the percent of entrained fish

that were struck by a blade when they entered and exited the LST. Two observers were used to independently view one replicate per velocity condition and fish size class. Review of multiple camera views and slowing the playback speed were used to assess fish behavior and blade contacts. Observers counted the number of fish avoiding turbine passage, encountering the blade sweep, and passing through the blade sweep (i.e., entrainment). During a second review of the selected videos, the observers recorded orientation (head first, tail first, or sideways) and speed relative to flow (faster, slower, or about the same velocity as the approach flow) for entrained fish as they passed through the upstream blade sweep. During this second review, the number of blade strikes for fish passing into and out of the turbine was also recorded.

Behavioral Testing

Behavioral trials were conducted for each turbine using the same species, size classes, flow approach velocities, and turbine rotational speeds that were evaluated during survival testing (Table 2-1). For these tests, the fish release system was moved upstream of the turbine approximately 7.6 m (25 ft), which resulted in a location near the upstream end of the narrowed channel section leading to the turbines. In addition to meeting logistical constraints associated with the system design and mounting, this location was considered a reasonable distance in which fish could orient to the flow and react to the turbines. The containment netting used for Welka UPG survival tests was removed from the front of the injector tube for the behavioral trials with this turbine (Figure 2-10). Underwater cameras were used to record video from several locations to evaluate fish behavior and passage through and around each turbine unit. A digital video recording (DVR) unit was used to document and synchronize the video images for up to four camera locations.

Fifty fish were used per trial and three replicate trials were conducted for each set of test conditions (species, size group, and approach velocity) evaluated during behavioral testing. On the day of testing, each test group was placed into a mobile holding tank and moved to the test flume area. Once the flume channel velocity and turbine speed parameters had been established the fish were released. After introduction, treatment fish movement through or around the turbine was monitored and recorded via underwater cameras for 30 minutes. At the velocities being tested (1.5 and 2.1 m/s), this time period was considered sufficient for most fish, if not all, to move or be swept downstream past the turbines. Once the 30 minute trial had elapsed the next test group was released. After three trials had been completed the isolation screen was lowered immediately upstream of the turbine to prevent fish from moving up or downstream of the turbine. The test flume was turned off at this time and the water level was lowered to allow for personnel to wade in the flume. Fish were then gently crowded with a seine net to allow for collection and counting. Because the focus of these tests was to assess behavior and avoidance, injury and delayed mortality assessments were not conducted for behavioral trials. However, immediate mortalities were recorded at the time of recovery following each trial.

Survival Data Analysis

The data analysis for the biological evaluation of the two hydrokinetic turbine designs involved assessments of immediate (1 hr) and delayed (48 hr) mortality and injury and scale loss for selected turbine operating conditions (approach velocity and turbine rotational speed), species, and size groups. Immediate and total (immediate plus 48-hour) passage survival rates were estimated and statistically analyzed using a maximum likelihood estimation (MLE) model developed for paired release-recapture studies with a single recapture event (Burnham et al. 1987; Skalski 1999). Turbine survival and 95% confidence intervals were calculated using pooled-replicate data for each set of test conditions (treatments) following procedures described by Skalski (1999). There were no statistical differences in survival detected among replicate trials within treatments for any of the test conditions evaluated (i.e., fish size and velocity), allowing the data to be pooled. The input parameters for survival estimates included the following:

N_C = total number of control fish recovered (alive and dead);

c = number of control fish recovered alive;

N_T = total number of treatment fish recovered (alive and dead); and

t = number of treatment fish (i.e., turbine passed) recovered alive.

Immediate (1-hr) and total (1-hr + 48-hr) control survival (S_C) and turbine survival (S_T) were calculated as:

$$S_C = \frac{c}{N_C} \quad (1)$$

$$S_T = \frac{tN_C}{N_T c} \quad (2)$$

with a variance for S_T of:

$$Var(S_T) = S_T^2 \left[\frac{1 - S_C S_T}{N_T S_C S_T} + \frac{(1 - S_C)}{N_C S_C} \right] \quad (3)$$

and a 95% confidence interval ($\alpha = 0.05$) of:

$$S_T \pm 1.96\sqrt{Var(S)} \quad (4)$$

Statistical differences in survival rates between treatment conditions (i.e., between size groups within velocity and between velocities within size group) were determined by non-overlapping confidence intervals. Assumptions associated with this model include: (1) all treatment fish have the same probability of survival; (2) all control fish have the same probability of survival; (3) survival probabilities from the point of the control release to recapture are the same for control and treatment fish; and (4) survival from the point of control release to recapture is conditionally independent of turbine survival.

The total number of fish recovered for each release group was used instead of the number released because some fish were not recovered until later tests. Although most unrecovered fish were later collected alive during a subsequent test, a small number of unrecovered treatment and control fish were collected dead during later tests. The source or time of death could not be determined for these fish. Also, marks on a small number of fish could not be located or identified after recovery. With the exception of a few replicate trials conducted at the beginning of the study, the number of fish without identifiable marks recovered during each trial was very low and the vast majority of unmarked recoveries were collected live. The exclusion of unrecovered fish and fish without identifiable marks had little or no effect on survival estimates, mainly because most of these recovered were recovered live. Even if these fish were included in the analysis and unmarked fish recovered dead were assigned to treatment groups, survival estimates would only change by a fraction of percent (and likely would be higher than reported) because most fish recovered during later tests and unmarked fish were recovered live and they accounted for less than 1% of the total fish released. Excluding these fish from the calculation of survival estimates was considered a prudent and conservative approach.

The proportion of fish descaled was adjusted with the control data to account for the effects of handling and testing procedures. The adjusted proportion descaled was calculated by dividing the proportion of treatment fish not descaled by the proportion of control fish not descaled, then subtracting the resulting quotient from one. Similar to the survival analysis, the replicate data were pooled for each set of test conditions when calculating the adjusted proportion of fish descaled.



*Figure 2-10
Downstream view of fish release system location used for behavioral trials*

Velocity Measurements

Velocity measurements were recorded to verify that the flume operating conditions produced the desired approach velocities with a relatively uniform distribution upstream of the test turbine location. Velocity measurements recorded by an ADCP were used to develop a predicted bow thruster output curve, such that bow thruster rpm could be used to set the approach velocity for each test. Once the appropriate rpm for each velocity condition was determined, a complete velocity profile was measured for each velocity condition and turbine type. Velocities in the flume were also measured directly upstream of the test turbine location in a 3 by 3 grid to determine the average velocity profile for a given condition across the flume channel (Figure 2-11). These velocity measurements were recorded using a Swoffer propeller-style velocity meter and are presented in Figure 2-12. Velocity measurements were also recorded at the exit of the injector tube for both turbines at each velocity condition and were about 1.4 m/s at the lower target velocity and 2.0 m/s for the higher velocity.

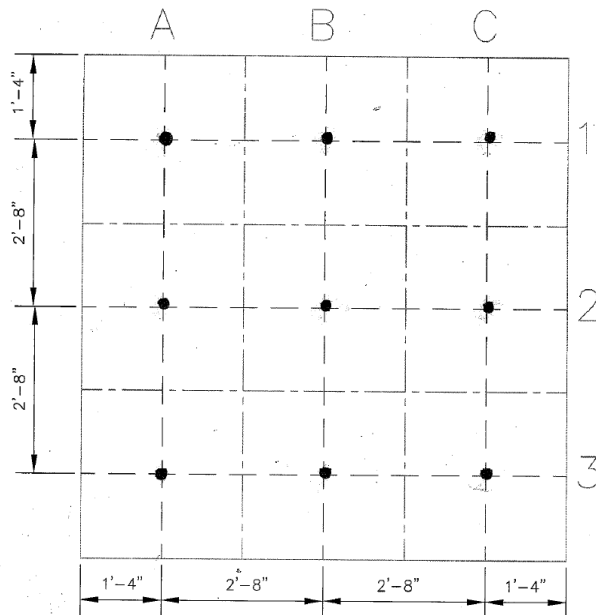

Figure 2-11
Velocity profile 3x3 grid, displaying each velocity measurement point

	A	B	C
1.5 m/s Target Test Conditoin			
1	1.46	1.51	1.44
2	1.50	1.40	1.54
3	1.12	1.35	1.31
2.1 m/s Target Test Conditoin			
1	2.05	2.11	2.02
2	2.07	1.99	2.06
3	--	--	--

Figure 2-12
Velocity measurements recorded with a Swiffer meter directly upstream of the test turbine location. Measurements could not be recorded at the deepest transect (3) at the higher target velocity (2.1 m/s) because the meter could not be held stable for accurate readings.



Section 3: Biological Evaluation – Results

Lucid Spherical Turbine

Survival Testing

The mean fork length of rainbow trout evaluated during LST trials was 149 mm (SD = 16) for the smaller size group and 250 mm (SD = 16) for the larger size group. The range of mean fish lengths for treatment groups was 138 mm to 158 mm for smaller fish and 247 mm to 250 mm for the larger fish. Mean length for control groups ranged from 137 mm to 163 mm for the smaller fish and 250 mm to 251 mm for larger fish (Table 3-1).

Recovery rates for treatment and control groups ranged from about 91.0 to 99.6% for smaller fish and 98.4 to 100.2% for the larger fish (Table 3-1). Recovery rates greater than 100% indicate more fish were recovered for a treatment or control group than were counted at the time of release. This may have occurred due to errors in the release counts or in the identification or recording of mark colors and fin locations during post-test fish evaluations. These types of sampling errors may have also contributed to recovery rates less than 100%. Also, some fish were not recovered during the trial of their release, but were collected during subsequent trials. All treatment and control fish that were recovered during later trials were live at the time of recovery. Some fish that were unaccounted for (particularly the smaller-sized fish) likely passed through the downstream isolation screen and the bow thrusters that re-circulate the flow through the flume. Seventy-nine fish recovered during survival evaluation trials with the LST did not have marks that could be identified during the post-test injury evaluation. After completing the trials with the first set of test conditions, improvements in marking techniques resulted in very few fish with unidentifiable marks in subsequent tests (Table 3-1). Unmarked fish could not be assigned to a release group and, therefore, were not included in the survival analysis. As discussed previously, this is a conservative approach given almost all of these fish were recovered live (Table 3-1). The few fish that were recovered during later trials were also excluded from the survival analysis. This was also considered conservative because these fish were all recovered live.

Table 3-1

Summary of fish release, recovery, and mortality data for rainbow trout tested with the LST during the survival evaluation

Approach Velocity (m/s)	Fish Size	Number of Trials	Test Group*	Mean FL and SD (mm)	Total Released	Recovered Live	Immediate Mortalities (1 hr)	Delayed Mortalities (48 hr)	Recovered Live during Later Test	Recovered Dead during Later Test
1.5	small	5	T	157.6 (21.8)	502	456	0	1	1	0
			C	162.9 (25.3)	502	482	0	1	1	0
			NM	-	-	63	0	0	-	-
2.1	small	5	T	137.7 (7.9)	506	498	6	2	0	0
			C	137.3 (8.1)	500	479	3	0	2	0
			NM	-	-	1	1	0	-	-
1.5	large	5	T	250.4 (16.2)	502	493	1	0	0	0
			C	250.4 (15.5)	503	494	3	0	0	0
			NM	-	-	14	0	0	-	-
2.1	large	5	T	247.4 (15.6)	500	499	2	6	0	0
			C	251.1 (15.5)	501	498	0	0	1	0
			NM	-	-	-	-	-	-	-

* T= treatment group, C= control group, NM= undetermined (no visible mark)

Immediate and total survival rates for rainbow trout were greater than 99% for all sets of test conditions evaluated with the LST, except for total survival of the larger fish tested at an approach velocity of 2.1 m/s, which was 98.4% (Table 3-2; Figure 3-1). Immediate survival was not significantly different between the two velocities tested with each size group, or between size groups at each velocity ($P > 0.05$; Figure 3-1). For the larger fish, total survival was significantly greater at the lower velocity ($P < 0.05$; Figure 3-1). There were no statistical differences in total survival between size groups at each velocity, or between velocities for the smaller fish ($P > 0.05$). The spherical design of the turbine did not allow for fish to be forced through the blade sweep, as was done with the ducted Welka UPG turbine using a containment net. Because all treatment fish were released within 250 to 300 mm (10 to 12 inches) of the upstream face of the turbine, the estimated survival rates represent the percentage of fish that encounter the turbine and proceed downstream by either actively passing around the turbine or via entrainment through the blade sweep, both without lethal injuries.

The percent of treatment fish recovered without visible external injuries exceeded 95% for both size classes and approach velocities evaluated with the LST (Table 3-3). The percent of control fish classified as uninjured was similar to treatment fish for both size classes and velocities (Table 3-3), indicating that most injuries observed for treatment fish likely resulted from handling and testing procedures and not interactions with the turbine. Also, turbine-related injury was expected to be minimal given that many fish were observed avoiding entrainment through the turbine blade sweep. Bruising appeared to be the most prevalent injury type, with few lacerations and eye injuries observed among treatment and control fish.

Table 3-2

Survival estimates (adjusted for control mortality) for rainbow trout evaluated with the LST. Survival rates above 100% resulted when control mortality was greater than treatment mortality.

Mean Fork Length (mm)	Approach Velocity (m/s)	Immediate Survival (1 hr) (%) ± 95% CI	Total Survival (1 hr + 48 hr) (%) ± 95% CI
161	1.5	100.00 ± 0.00	99.99 ± 0.59
138	2.1	99.43 ± 1.18	99.03 ± 1.30
250	1.5	100.40 ± 0.80	100.40 ± 0.80
249	2.1	99.60 ± 0.55	98.40 ± 1.10

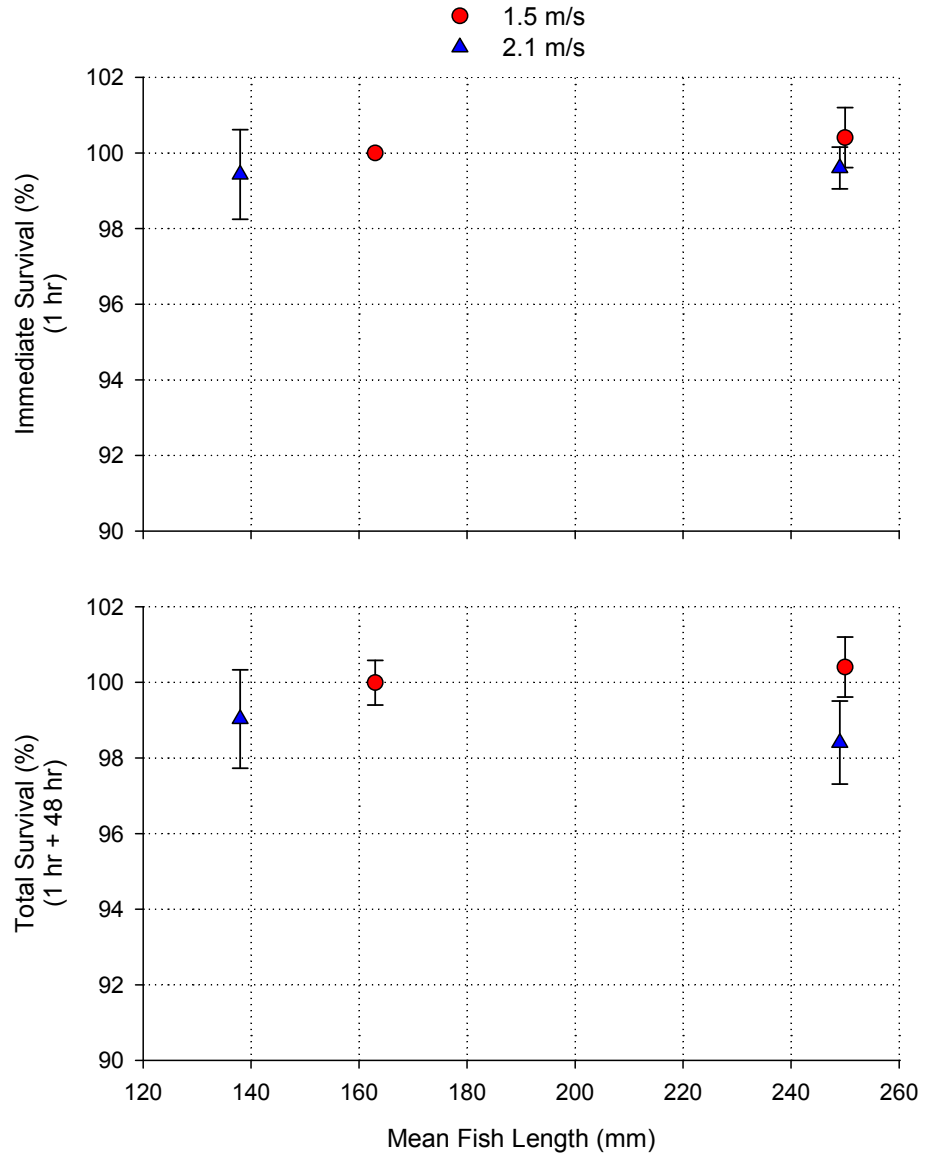

Figure 3-1
 Immediate (1 hr) and total (1 hr + 48 hr) survival rates (\pm 95% CI) for rainbow trout tested with the LST. Non-overlapping confidence intervals indicate statistically significant differences between survival estimates.

Table 3-3

Percent of rainbow trout recovered during LST survival testing that were observed with external injuries

Approach Velocity (m/s)	Mean Fork Length (mm)	Live/Dead	Total Number Examined		Uninjured (%)		Bruising (%)		Laceration (%)		Severed Body (%)		Eye Injury (%)	
			T	C	T	C	T	C	T	C	T	C	T	C
1.5	161	Live	455	481	99.6	99.8	0.0	0.2	0.2	0.0	0.0	0.0	0.0	0.0
		Dead	1	1	0.0	0.0	0.0	0.0	0.0	0.0	0.0	0.0	0.0	100.0
		Total	456	482	99.3	99.6	0.0	0.2	0.2	0.0	0.0	0.0	0.0	0.2
2.1	138	Live	496	479	97.0	99.4	0.0	0.0	0.2	0.0	0.0	0.0	0.0	0.0
		Dead	8	3	37.5	0.0	50.0	100.0	0.0	0.0	0.0	0.0	0.0	0.0
		Total	504	482	96.0	98.8	0.8	0.6	0.2	0.0	0.0	0.0	0.0	0.0
1.5	250	Live	493	494	99.2	98.8	0.2	0.0	0.4	0.4	0.0	0.0	0.0	0.0
		Dead	1	3	100.0	100.0	0.0	66.7	0.0	33.3	0.0	0.0	0.0	33.3
		Total	494	497	99.2	98.8	0.2	0.4	0.4	0.6	0.0	0.0	0.0	0.2
2.1	249	Live	493	498	97.8	98.8	0.2	0.0	0.0	0.0	0.0	0.0	2.0	1.2
		Dead	8	0	25.0	0.0	37.5	0.0	12.5	0.0	0.0	0.0	12.5	0.0
		Total	501	498	96.6	98.8	0.8	0.0	0.2	0.0	0.0	0.0	2.2	1.2

The percent of fish classified as descaled was relatively high for both treatment and control groups, particularly for the smaller size class of fish (TWhen adjusted for control data, however, the percent of turbine-exposed fish (which either passed around or through the turbine) that were descaled was low, ranging from 0.0% to 4.5% (live and dead fish combined). Descaling was more prevalent for fish recovered dead.

Given that injury, scale loss, and survival were generally similar between treatment and control fish, a likely source of fish damage (and some of the observed mortality) was the area downstream of the turbine where flow expanded from the 8-ft channel leading to the turbine to the full 20 ft width of the flume. Portions of this area had turbulent flow and sufficient velocity to cause some fish to impinge on the downstream isolation screen. Although test durations were relatively short (10 minutes), in part to reduce the potential for injury and mortality in the area downstream of the turbines, fish that contacted the downstream screen and/or impinged on it would have been more susceptible to physical damage, as evidenced by the control group data.

A review of underwater videos from a single trial conducted with each velocity and size class demonstrated that avoidance of turbine passage by treatment fish of both size classes was high (82 to 94%) at the two approach velocities evaluated (Table 3-5). For both size classes, avoidance was greater at the lower velocity (1.5 m/s). Of the fish that were entrained, most of the smaller fish passed through the blade sweep tail first (i.e., head upstream, positive rheotaxis), whereas larger fish had a greater tendency to enter the blade sweep sideways at the lower test velocity and head first at the higher velocity. Most entrained fish of both size classes passed through the upstream blade sweep at either the same speed as the flow or slower, at both approach velocities evaluated (Table 3-5). The estimated percent of entrained fish struck by a blade during the initial passage through the blade sweep (i.e., on upstream side of turbine) was relatively high for both size groups (about 53 to 91%), and larger fish appeared to be less susceptible to strike (Table 3-5) at both approach velocities. Blade strike was less common when entrained fish passed out of the turbine through the blade sweep on the downstream side (Table 3-5). Also, the percent of fish struck by a blade was higher at the lower approach velocity for both size groups, with the exception of the smaller fish exiting the turbine. The variability in the video observation data likely represents sampling error resulting from the difficulty in ascertaining the path of all entrained fish through the turbine, which depended on fish location relative to cameras and the approach velocity. There was considerably more air entrainment in the flume at the higher approach velocity, making it more difficult to observe fish and to determine whether they were struck during turbine passage.

Figure 3-2 demonstrates common avoidance behaviors observed during video observation of trout encountering the LST. The larger trout were able to hold position in the flow at the exit of the injection tube and immediately upstream of the turbine blade sweep, often for several minutes. As they began to move downstream, the majority of fish drifted to either side of the turbine. Many of the fish holding position in front of the turbine were seen slowly drifting back in

the flow until their tail was struck by the blade, at which point these fish either swam forward or were displaced in the direction of the blade movement, passing downstream to the side of the turbine. The smaller trout had more difficulty maintaining position in the flow and most were observed exiting the injection tube and drifting immediately downstream around the turbine on either side. Other common behaviors documented by video observations of rainbow trout evaluated during survival testing with the LST included fish being entrained through the turbine (Figure 3-3) and blade strikes which occurred during these interactions. Some fish entrained into the turbine could be observed swimming within the sphere of the blades for brief periods of time prior to exiting in the downstream direction.

Table 3-4

Percent of rainbow trout classified as descaled during survival tests with the LST

Approach Velocity (m/s)	Mean Fork Length (mm)	Live/Dead	Control		Treatment		% Treatment Descaled Adjusted for Control Data
			Number Examined	% Classified as Descaled	Number Recovered	% Classified as Descaled	
1.5	161	Live	481	70.9	455	70.8	0.0
		Dead	1	100.0	1	100.0	0.0
		Total	482	71.0	456	70.6	0.0
2.1	138	Live	479	56.8	496	57.7	2.0
		Dead	3	100.0	8	87.5	0.0
		Total	482	57.1	504	58.1	2.5
1.5	250	Live	494	19.4	493	18.7	0.0
		Dead	3	33.3	1	0.0	0.0
		Total	497	19.5	494	18.6	0.0
2.1	249	Live	498	6.6	493	9.7	3.3
		Dead	0	0.0	8	75.0	75.0
		Total	498	6.6	501	10.8	4.5

Table 3-5

Summary of fish avoidance and entrainment data from video observations recorded during rainbow trout survival tests with the LST. Video observations were recorded for a single trial conducted with each velocity and fish size group by two observers. The avoidance and entrainment data recorded by each observer were averaged. The observations are based on approximately 100 fish being released for each trial.

Approach Velocity (m/s)	Mean Fish Length (mm)	Mean Number of Fish Observed	Avoided Turbine Passage (%)	Entrained through Turbine (%)	Orientation of Entrained Fish (%)			Speed of Entrained Fish Relative to Flow Velocity (%)			Entrained Fish Struck by Blade (%)	
					Head First	Tail First	Side First	Same	Slower	Faster	Entering Turbine	Leaving Turbine
1.5	161	89.5	93.9	6.1	27.3	45.5	27.3	45.5	36.4	18.2	90.9	9.1
2.1	138	83.5	89.8	10.2	5.9	94.1	0.0	41.2	47.1	11.8	82.4	23.5
1.5	250	91.5	94.0	6.0	36.4	18.2	45.5	81.8	0.0	18.2	90.9	36.4
2.1	249	90.5	81.8	17.7	59.4	25.0	15.6	50.0	34.4	15.6	53.1	9.4

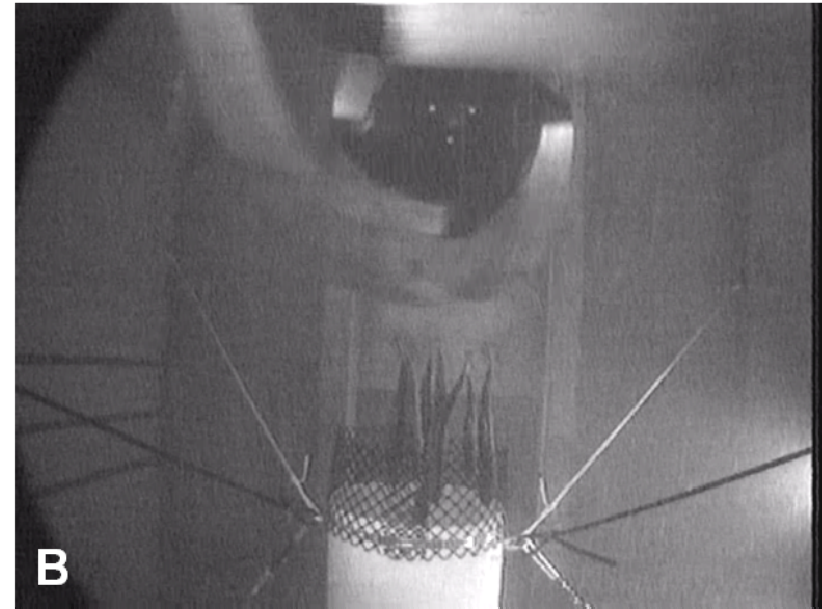
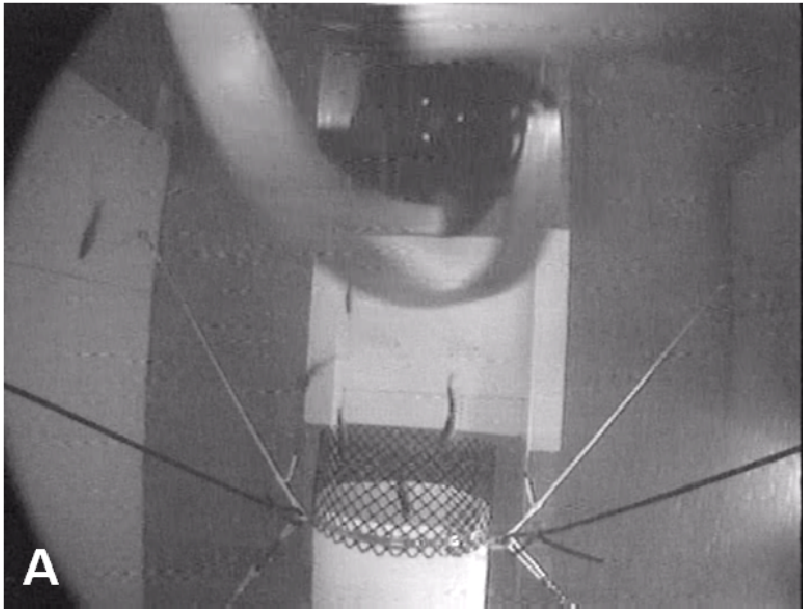
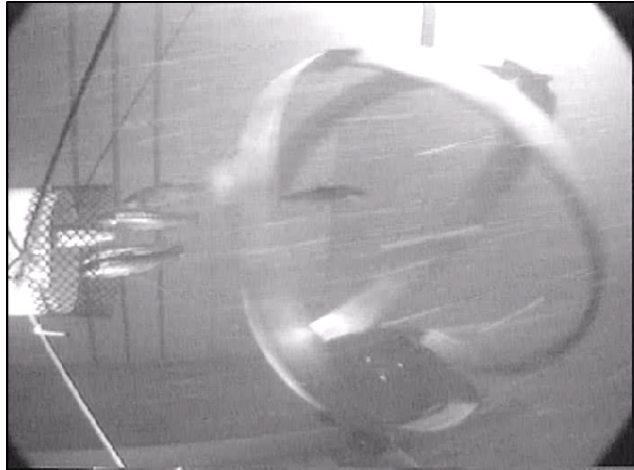

Figure 3-2

Video observations (top view) demonstrating avoidance of the LST during survival testing with of 125-mm (A) and 250-mm (B) rainbow trout avoidance at an approach velocity of 1.5 m/s. Fish of both size groups were observed moving to the sides of the turbine and the larger trout typically maintained position between the exit of the release tube and the upstream face of the turbine blade sweep (B) for several minutes before passing downstream through or around the turbine.



*Figure 3-3
Side view from underwater camera showing 250 mm rainbow trout maintaining position directly upstream of the turbine blade sweep and a fish passing through turbine during survival testing*

Behavioral Tests

For behavioral tests, the release system was moved to the upstream end of the test channel to allow fish the opportunity to completely avoid interaction with the turbine. At the start of each behavioral trial, rainbow trout were observed on video as they were placed inside the injection pipe. All fish quickly oriented in the upstream direction while still inside the pipe, eventually falling back and exiting into the test channel. No cameras were located in the channel upstream of the turbine unit so it was not possible to observe the approximate number of fish that moved downstream and those that held positions upstream for extended durations. However, at the completion of each test trial an isolation screen was lowered immediately upstream of the turbine to prevent fish from moving up or downstream past the turbine. During collection, fish recovered downstream and upstream of the turbine, along with any immediate mortalities, were enumerated (Table 3-6). As expected based on swimming ability, almost all of the smaller fish moved downstream past the LST and a greater proportion of larger fish remained upstream at both approach velocities evaluated (Table 3-6). No mortalities occurred during behavioral tests with the LST.

General video observations during behavioral testing at the 1.5 m/s velocity demonstrated that fish passing downstream towards the turbine units swam or drifted along the floor or walls of the flume. Consequently, few if any fish interacted with the turbine or were entrained through the blade sweep. Several fish were observed drifting along the flume bottom and, after encountering the turbine anchoring frame, maintained position below the turbine for brief periods of time before proceeding downstream. Video quality at the higher velocity (2.1 m/s) was poor, mainly due to the presence of entrained air bubbles which severely restricted all camera views of fish approaching the turbine. In general, video observations from the LST behavior tests demonstrated that most fish followed paths along the walls and floor of the test flume. Very few fish were observed entering or interacting with the turbine unit. The few rainbow trout that were observed approaching the turbine at either velocity were actively swimming (i.e., tail beating was visible) and facing upstream (positive rheotaxis).

Table 3-6

Summary of release and recapture for behavioral tests with conducted with rainbow trout and the LST

Fish Size Group	Approach Velocity (m/s)	Total Number Released	Number Recovered Downstream	Number Recovered Upstream	Number Recovered Dead	Total Number Recovered
Small	1.5	151	146	5	0	151
	2.1	150	149	2	0	151
Large	1.5	150	90	60	0	150
	2.1	150	124	26	0	150

Welka UPG Turbine

Survival Tests

Rainbow Trout

The mean fork length of rainbow trout evaluated during survival tests with the Welka turbine was 124 mm (SD =6) for the smaller size class and 240 mm (SD = 16) for the larger size group. Mean length of smaller fish for all treatment groups was 125 mm. The range of mean fish lengths was 231 mm to 247 mm for treatment groups of the larger fish. Control groups had a range of mean lengths of 124 mm to 125 mm for smaller size groups and 232 mm to 250 mm for larger size groups (Table 3-7).

Recovery rates of treatment and control groups evaluated during Welka survival testing ranged from 90.4 to 93.4% for smaller rainbow trout and 99.6 to 101% for the larger size group (Table 3-7). Recovery rates greater than 100% indicate more fish were recovered than counted at the time of release. This may have occurred due to errors in the release counts or in the identification or recording of mark colors and fin locations during post-test evaluations. Some fish were not recovered during the trial of their release, but were collected during subsequent trials. The percent of unrecovered fish was greater for the smaller size class, most likely because some smaller fish were capable of passing through the mesh of the downstream isolation screen. Fish recovered during later trials accounted for about 2% or less of the total number released and most (73%) were recovered live. As a conservative approach, these fish were excluded from the survival analysis. During survival testing with the Welka UPG turbine, all recovered rainbow trout had a detectable mark.

Immediate and total turbine passage survival rates for rainbow trout were 100% for the smaller fish evaluated at both approach velocities and the larger fish tested at the lower velocity (1.5 m/s) (Table 3-8). Immediate and total survival of the larger fish evaluated at the higher velocity (2.1 m/s) were both 99.4% (Table 3-8). The only statistical differences detected among the survival rates was between the smaller and larger size groups at an approach velocity of 2.1 m/s, for which the smaller fish had significantly higher immediate and total survival ($P < 0.05$; Figure 3-4). The use of a containment net with the Welka UPG turbine resulted in all released treatment fish passing downstream through the turbine's blade sweep. Consequently, the survival estimates represent the expected survival of fish entrained through a Welka UPG turbine at the approach velocities and resulting rotation speeds evaluated. This is in contrast to the tests with the LST, for which survival estimates were for fish that encountered the turbine and passed either downstream through or around it.

Table 3-7

Summary of fish release, recovery, and mortality data for rainbow trout tested with the Welka UPG turbine during the survival evaluation

Approach Velocity (m/s)	Fish Size	Number of Trials	Test Group	Mean FL and SD (mm)	Total Released	Recovered Live	Immediate Mortalities (1 hr)	Delayed Mortalities (48 hr)	Recovered Live during Later Test	Recovered Dead during Later Test
1.5	small	5	T	125.2 (6.5)	502	463	2	1	8	3
			C	125.1 (6.4)	500	461	6	1	4	2
2.1	small	5	T	125.1 (6.6)	500	451	1	0	4	2
			C	124.3 (5.7)	500	445	8	0	6	1
1.5	large	5	T	230.8 (16.1)	499	504	0	0	3	0
			C	231.9 (15.7)	498	496	0	0	1	1
2.1	large	5	T	247.4 (17.5)	496	496	3	0	1	0
			C	250.4 (15.4)	501	499	0	0	0	1

Table 3-8

Turbine passage survival estimates (adjusted for control mortality) for rainbow trout evaluated with the Welka UPG turbine. Survival rates above 100% resulted when control mortality was greater than treatment mortality.

Mean Fork Length (mm)	Approach Velocity (m/s)	Immediate Survival (1 hr) (%) ± 95% CI	Total Survival (1 hr + 48 hr) (%) ± 95% CI
125	1.5	100.87 ± 1.21	100.87 ± 1.35
125	2.1	101.57 ± 1.33	101.57 ± 1.33
231	1.5	100.00 ± 0.00	100.00 ± 0.00
248	2.1	99.40 ± 0.68	99.40 ± 0.68

The percent of uninjured rainbow trout from treatment groups recovered during survival trials with the Welka UPG turbine ranged from about 75 to 94% (Table 3-9). For control groups, the rates of uninjured fish were similar to treatment groups, ranging from about 75 to 95% (Table 3-9). The percent of treatment and control fish collected uninjured was higher during trials with the larger size groups than with the smaller fish. Bruising was the most common injury observed, with only a few fish experiencing lacerations or eye injuries (Table 3-9). One treatment fish recovered during a trial with the larger size class at a velocity of 2.1 m/s suffered a severed body. The cause of this injury could not be determined, but because of the low strike velocity of the Welka UPG turbine, it likely did not occur from a blade strike. The overall similarity in treatment and control fish injury rates indicates that most injuries suffered by treatment fish were likely due to handling and testing procedures and were not associated with passage through the Welka UPG turbine.

The percent of rainbow trout classified as descaled was lower for larger fish and for trials at the lower velocity (1.5 m/s) for both treatment and control groups (Table 3-10). However, although similar, descaling of control fish was greater than it was for treatment fish for three of the four sets of test conditions. Consequently, when adjusted for control data, the percent of treatment fish descaled was 0% for all test conditions, except for the smaller fish evaluated at the lower velocity. These results indicate that observed descaling of treatment fish was the result of handling and testing procedures and not passage through the Welka UPG turbine.

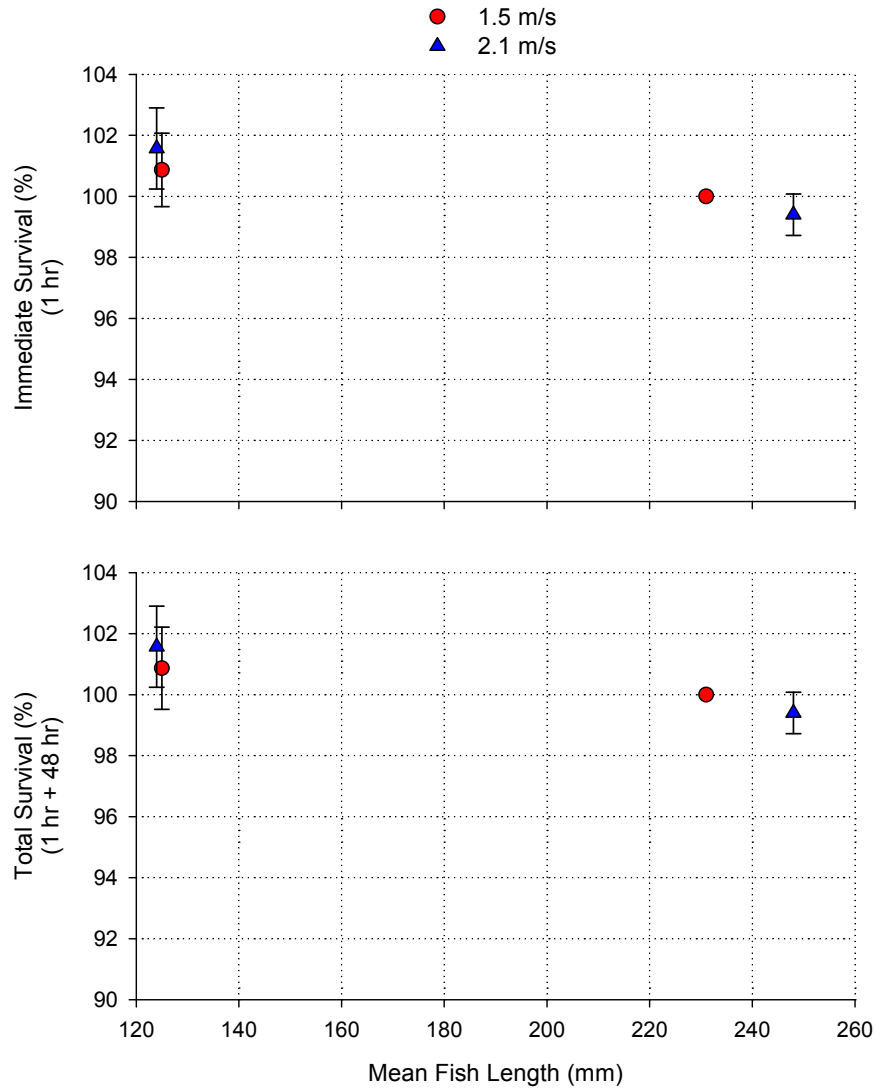

Figure 3-4
Immediate (1 hr) and total (1 hr + 48 hr) survival rates (\pm 95% CI) for rainbow trout tested with the Welka UPG. Non-overlapping confidence intervals indicate statistical differences between survival estimates.

Largemouth Bass

The mean fork length of largemouth bass evaluated during Welka turbine survival testing was 125 mm (SD =11) for the smaller size class and 242 mm (SD = 20) for the larger fish. There was little variability in the range of mean lengths for treatment control groups with the smaller fish. Mean lengths of the larger size treatment groups ranged from 237 to 247 mm and control groups with the larger fish ranged from 239 to 246 mm for larger size groups (Table 3-11).

Recovery rates of largemouth bass treatment and control groups evaluated for survival with the Welka UPG turbine ranged from 98.6% to 100% for smaller fish and 99.4 to 100.2% for the larger size group (Table 3-11). Recovery rates greater than 100% indicate more fish were recovered than counted at the time of release. This may have occurred due to errors in the release counts or in the identification or recording of mark colors and fin locations during post-test evaluations. These types of sampling error may have also contributed to the small percentage of fish that were unaccounted for during some of the trials. Unlike rainbow trout, no unrecovered largemouth bass were collected during subsequent trials. Nine largemouth bass did not have identifiable marks following recovery (Table 3-11), most of these occurred with the smaller fish tested at the lower velocity. All of the largemouth bass without a discernable mark were recovered live.

Immediate mortalities only occurred during the trials with the smaller bass and were greater for both control and treatment fish at the higher velocity. Control and treatment delayed mortality was relatively high for this test condition (i.e., smaller fish, higher velocity), but given that immediate and delayed mortality were greater for control fish, the observed mortality of treatment fish was likely due to handling and testing procedures and not associated with turbine passage. Higher rates of control mortality may have occurred due to greater impingement on the downstream isolation screens compared to treatment fish. Control fish were released closer to the downstream screen and had less time to orient in the flow before encountering the screen. Although velocities were lower downstream of the turbine due to the expansion to full flume width, they were still relatively high at both test velocities (about 0.9 m/s and 1.5 ft/s at the two test channel approach velocities that were evaluated).

Table 3-9

Percent of rainbow trout recovered during Welka UPG turbine survival testing that were observed with external injuries

Approach Velocity (m/s)	Mean Fork Length (mm)	Live/Dead	Total Number Examined		Uninjured (%)		Bruising (%)		Laceration (%)		Severed Body (%)		Eye Injury (%)	
			T	C	T	C	T	C	T	C	T	C	T	C
1.5	125	Live	462	460	75.3	76.5	24.5	23.0	0.0	0.0	0.0	0.0	0.0	0.0
		Dead	3	7	33.3	0.0	0.0	57.1	0.0	0.0	0.0	0.0	0.0	14.3
		Total	465	467	75.1	75.4	24.3	23.6	0.0	0.0	0.0	0.0	0.0	0.2
2.1	125	Live	451	445	85.4	88.1	12.6	14.2	0.0	0.2	0.0	0.0	0.0	0.0
		Dead	1	8	0.0	0.0	0.0	87.5	0.0	12.5	0.0	0.0	0.0	25.0
		Total	452	453	85.2	86.5	12.6	15.5	0.0	0.4	0.0	0.0	0.0	0.0
1.5	231	Live	504	496	94.0	95.2	5.6	4.8	0.2	0.0	0.0	0.0	0.2	0.0
		Dead	0	0	0.0	0.0	0.0	0.0	0.0	0.0	0.0	0.0	0.0	0.0
		Total	504	496	94.0	95.2	5.6	4.8	0.2	0.0	0.0	0.0	0.0	0.2
2.1	248	Live	496	499	89.7	90.0	6.9	6.4	0.0	0.2	0.4	0.0	3.4	3.4
		Dead	3	0	0.0	0.0	66.7	0.0	0.0	0.0	33.3	0.0	33.3	0.0
		Total	499	499	89.2	90.0	7.2	6.4	0.0	0.2	0.6	0.0	3.6	3.4

Table 3-10

Percent of rainbow trout classified as descaled during survival tests with Welka UPG turbine

Approach Velocity (m/s)	Mean Fork Length (mm)	Live/Dead	Control		Treatment		% Treatment Descaled Adjusted for Control Data
			Number Examined	% Classified as Descaled	Number Recovered	% Classified as Descaled	
1.5	125	Live	460	22.8	462	26.6	4.9
		Dead	7	42.9	3	0.0	0.0
		Total	467	23.1	465	26.5	4.3
2.1	125	Live	445	35.3	451	29.3	0.0
		Dead	8	37.5	1	0.0	0.0
		Total	453	35.3	452	29.2	0.0
1.5	231	Live	496	5.6	504	4.4	0.0
		Dead	0	-	0	0.0	0.0
		Total	496	5.6	504	4.4	0.0
2.1	248	Live	499	20.8	496	19.4	0.0
		Dead	0	-	3	66.7	66.7
		Total	499	20.8	499	19.6	0.0

Table 3-11

Summary of fish release, recovery, and mortality data for largemouth bass tested with the Welka UPG turbine during the survival evaluation

Approach Velocity (m/s)	Fish Size	Number of Trials	Test Group	Mean FL and SD (mm)	Total Released	Recovered Live	Immediate Mortalities (1 hr)	Delayed Mortalities (48 hr)	Recovered Live during Later Test	Recovered Dead during Later Test
1.5	small	5	T	124.8 (11.4)	499	498	1	2	0	0
			C	124.5 (10.3)	497	488	2	0	0	0
			NM	-	-	7	0	0	-	-
2.1	small	5	T	125.2 (10.7)	502	499	3	15	0	0
			C	123.3 (11.1)	496	483	7	24	0	0
			NM	-	-	2	0	1	-	-
1.5	large	5	T	237.0 (20.1)	498	499	0	1	0	0
			C	239.1 (21.0)	499	497	0	1	0	0
			NM	-	-	-	-	-	-	-
2.1	large	5	T	246.6 (18.0)	501	498	0	2	0	0
			C	246.1 (18.9)	499	499	0	0	0	0
			NM	-	-	-	-	-	-	-

Immediate turbine passage survival for largemouth bass tested with the Welka UPG turbine was 100% for both size groups and approach velocities (Table 3-12). Total turbine passage survival was greater than 99% for all test conditions. Statistically significant differences were not detected among any of the test conditions (fish size and approach velocity) evaluated with largemouth bass ($P > 0.05$; Figure 3-5). Some of the survival estimates were greater than 100% for tests with the smaller fish due to control mortality being slightly higher than treatment mortality for several trials. The control release point was closer to the downstream isolation screen and may not have allowed the smaller fish sufficient time to orient to the flow and avoid contact with and impingement on the screen, particularly at the higher approach velocity. The use of a containment net with the Welka UPG turbine resulted in all released treatment fish passing downstream through the turbine's blade sweep. Consequently, the survival estimates represent the expected survival of fish entrained through Welka UPG turbine at the approach velocities and resulting rotational speeds evaluated. This is in contrast to the tests with the LST, for which survival estimates were for fish that encountered the turbine and either passed downstream through or around the turbine.

Table 3-12

Turbine passage survival estimates (adjusted for control mortality) for largemouth bass evaluated with the Welka UPG turbine. Survival rates above 100% resulted when control mortality was greater than treatment mortality.

Mean Fork Length (mm)	Approach Velocity (m/s)	Immediate Survival (1 hr) (%) \pm 95% CI	Total Survival (1 hr + 48 hr) (%) \pm 95% CI
125	1.5	100.21 \pm 0.69	99.81 \pm 0.89
124	2.1	100.84 \pm 1.27	102.93 \pm 2.94
238	1.52	100.00 \pm 0.00	100.00 \pm 0.56
246	2.1	100.00 \pm 0.00	99.60 \pm 0.56

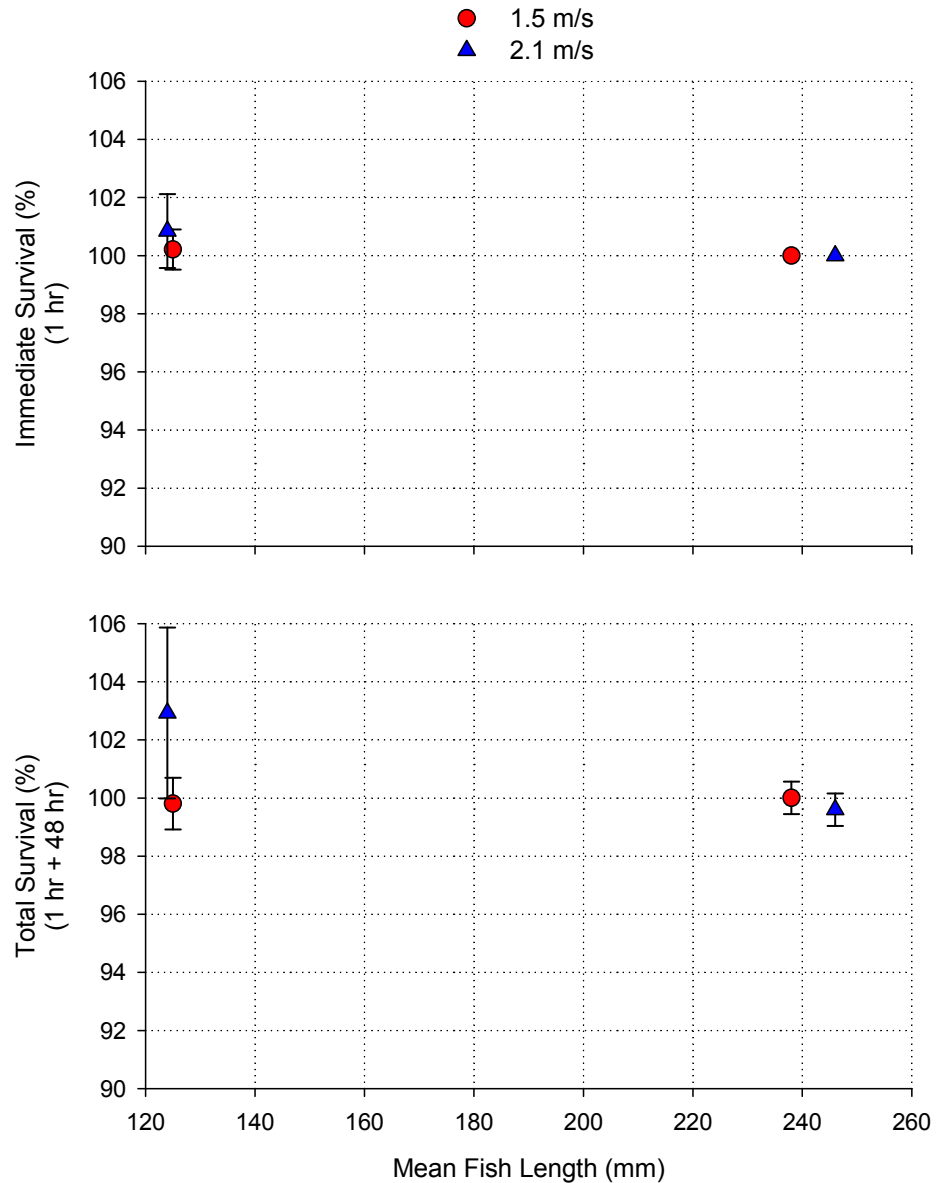

Figure 3-5
Immediate (1 hr) and total (1 hr + 48 hr) survival rates (\pm 95% CI) for largemouth bass tested with the Welka UPG. Non-overlapping confidence intervals indicate statistically significant differences between survival estimates.

The percent of largemouth bass classified as uninjured based on the absence of visible external injuries was 97% or greater for both size groups and approach velocities evaluated (Table 3-13). The percent of uninjured control fish was similar, exceeding 94% for all test conditions. Consequently, most injuries observed for treatment fish can be attributed to handling and testing procedures and not passage through the Welka UPG turbine.

Table 3-13

Percent of largemouth bass recovered during Welka UPG turbine survival testing that were observed with external injuries

Approach Velocity (m/s)	Mean Fork Length (mm)	Live/ Dead	Total Number Examined		Uninjured (%)		Bruising (%)		Laceration (%)		Severed Body (%)		Eye Injury (%)	
			T	C	T	C	T	C	T	C	T	C	T	C
1.5	125	Live	496	488	98.6	99.6	0.0	0.0	0.2	0.0	0.0	0.0	0.4	0.0
		Dead	3	2	33.3	100.0	33.3	50.0	0.0	0.0	0.0	0.0	33.3	0.0
		Total	499	490	98.2	99.6	0.2	0.2	0.2	0.0	0.0	0.0	0.6	0.0
2.1	124	Live	484	459	99.0	97.8	0.0	0.0	0.8	1.7	0.0	0.0	0.4	0.2
		Dead	18	31	61.1	58.1	16.7	19.4	0.0	3.2	0.0	0.0	0.0	0.0
		Total	502	490	97.6	95.3	0.6	1.2	0.8	1.8	0.0	0.0	0.4	0.2
1.5	238	Live	498	496	97.2	95.0	0.0	0.0	3.2	4.6	0.0	0.0	0.0	0.0
		Dead	1	1	0.0	0.0	100.0	100.0	0.0	0.0	0.0	0.0	0.0	0.0
		Total	499	497	97.0	94.8	0.2	0.2	3.2	4.6	0.0	0.0	0.0	0.0
2.1	246	Live	496	499	98.6	98.6	0.0	0.0	1.4	1.6	0.0	0.0	0.0	0.0
		Dead	2	0	50.0	0.0	50.0	0.0	0.0	0.0	0.0	0.0	0.0	0.0
		Total	498	499	98.4	98.6	0.2	0.0	1.4	1.6	0.0	0.0	0.0	0.0

Descaling rates were variable, but greater for both treatment and control fish at the higher approach velocity (Table 3-14). Percent descaled was also typically higher for control fish. After adjusting for control data, the percent of treatment fish classified as descaled was essentially 0% for both size groups and velocities.

As stated previously, during survival tests with the Welka UPG turbine fish were forced to pass through the turbine by using a containment net around the fish release system and upstream perimeter of the turbine. Fish were not able to swim outside the blade sweep of a turbine as they passed downstream. The containment net and the duct around the turbine made detailed video observations of fish behavior difficult, particularly at the higher velocity, for which underwater video was also obstructed by entrained air. Therefore, data on fish orientation, swim speeds, and blade strikes were not collected as was done for survival trials with the LST.

Figure 3-6 shows some of the common behaviors that were observed at the lower velocity (1.5 m/s)

Behavioral Tests

At the start of each behavioral trial, rainbow trout and largemouth bass were observed on video as they were placed inside the injection pipe. All fish quickly oriented in the upstream direction while still inside the pipe, eventually falling back and exiting into the test channel. No cameras were located upstream of the turbine unit so it was not possible to observe the approximate number of fish that moved downstream and that held positions upstream for extended durations. However, at the completion of each test trial an isolation screen was lowered immediately upstream of the turbine to prevent fish from moving up or downstream of the turbine at the end of each behavioral trial. During collection, fish recovered downstream and upstream of the turbine were documented, along with any immediate mortality (Table 3-15). A relatively high number of mortalities occurred for the smaller bass, most likely due to impingement on the downstream screen, particularly at the higher approach velocity. Several mortalities were also observed for the larger bass and the smaller rainbow trout. The smaller fish of both species and the larger bass likely did not have sufficient swimming ability to avoid impingement on the downstream screen for the extended duration of the behavioral trials (30 minutes). Also, video observations, as described below, indicated most fish passed downstream below or to the side of the Welka turbine.

General video observations during behavioral testing at the 1.5 m/s velocity demonstrated that fish passing downstream towards the turbine units swam or drifted along the floor or walls of the flume. Both species appeared to use these structures as guidance mechanism which allowed them to pass downstream without encountering the turbine blade sweep. Several fish were observed drifting along the flume bottom and holding position when they encountered the supporting frame on the flume floor below the turbine. Video observations at the higher velocity were difficult to make due to the presence of entrained air bubbles, which severely limited the ability to see fish approaching the turbine.

Table 3-14

Percent of largemouth bass recovered during Welka turbine trials that were observed with descaling

Approach Velocity (m/s)	Mean Fork Length (mm)	Live/Dead	Control		Treatment		% Treatment Descaled Adjusted for Control
			Number Examined	% Classified as Descaled	Number Recovered	% Classified as Descaled	
1.5	124.6	Live	488	1.4	496	0.0	0.0
		Dead	2	0.0	3	0.0	0.0
		Total	490	1.4	499	0.0	0.0
2.1	124.2	Live	459	55.6	484	34.5	0.0
		Dead	31	58.1	18	55.6	0.0
		Total	490	55.7	502	35.3	0.0
1.5	238.1	Live	496	0.4	498	0.6	0.2
		Dead	1	100.0	1	100.0	0.0
		Total	497	0.6	499	0.8	0.2
2.1	246.4	Live	499	28.5	496	20.6	0.0
		Dead	0	0.0	2	50.0	50.0
		Total	499	28.5	498	20.7	0.0

Most rainbow trout observed approaching the turbine were actively swimming (i.e., tail beating was visible) and facing upstream. Largemouth bass, however, were more likely to drift passively, particularly at the higher channel velocity. Many bass were observed facing upstream but were not actively swimming. In general, video observations from Welka turbine behavior tests demonstrated that most fish followed flow paths along the walls and floor of the test flume. Very few fish were observed passing through or interacting with the turbine.



Figure 3-6
Side camera view (A) showing a fish being struck by a blade and top view (B) showing fish swimming immediately upstream of the blade sweep during testing at an approach velocity of 1.5 m/s.

Table 3-15

Summary of release and recapture data for behavioral tests with largemouth bass (LMB) and rainbow trout (RBT) and the Welka UPG turbine

Species	Fish Size	Approach Velocity (m/s)	Total Number Released	Number Recovered Downstream	Number Recovered Upstream	Number Recovered Dead	Total Number Recovered
LMB	small	1.5	150	136	1	10	147
		2.1	150	112	0	36	148
	large	1.5	150	147	0	1	148
		2.1	150	141	0	9	150
RBT	small	1.5	150	117	21	3	141
		2.1	150	137	4	2	143
	large	1.5	150	89	61	0	150
		2.1	150	145	5	0	150

Section 4: Theoretical Predictions of Blade Strike Probability and Mortality

Theoretical models for the probability of blade strike have been developed for use with conventional hydro turbines by several researchers (Von Raben 1957; Franke et al. 1997; Turnpenny et al. 2000; Ploskey and Carlson 2004; Hecker and Allen 2005). Also, some studies have investigated the effects of leading edge blade geometry (shape and thickness), blade speed, and fish orientation on strike injury and survival (Turnpenny et al. 1992; EPRI 2008, 2011b). The blade strike data have been incorporated into existing theoretical models in order to predict blade strike mortality, as well as the probability of strike, for fish passing through conventional hydro turbines.

In concept, the general theoretical model developed for predicting strike probability and mortality for conventional turbines can be applied to hydrokinetic turbines because the mechanics of fish passing through turbines of each application type are, for the most part, the same. That is, strike probability for fish passing through conventional and hydrokinetic turbine designs will be a function of fish length, the number of blades, turbine rotational speed, relative velocity of fish to blade, and the axial angle of the approach flow. Strike mortality for both turbine types is dependent on the ratio of fish length to leading edge blade thickness, strike velocity (relative velocity of fish to blade), and fish orientation. However, an important component of strike probability and mortality models that needs to be considered in their application to hydrokinetic turbines is the velocity of fish as they pass through the blade sweep of a turbine. For conventional hydro turbines, fish velocity is assumed to be that of the inflow velocity, which typically is very high (> 6 m/s). Hydrokinetic turbines operate at lower approach flow velocities (perhaps between 1 to 5 m/s depending on the location and turbine design), and some fish may be able to swim against these velocities to a certain degree.

Because fish velocity is inversely related to strike probability (i.e., slower fish speeds will result in greater strike probabilities and higher speeds will result in lower strike probabilities), the probability that fish will be struck by a turbine blade will be greater if fish attempt to swim against the flow as they move downstream rather than simply travel at the speed of the ambient current. Alternatively, fish could exhibit downstream movement faster than the flow velocity which would result in lower strike probabilities. This also means that fish approaching a hydrokinetic turbine may be able to take evasive actions that

include swimming faster or slower than the flow velocity in order to avoid being struck by a blade. For simplicity and because there is little or no reliable information on fish speed and behavior approaching various hydrokinetic turbine designs, our application of the strike probability and mortality model to the two turbines evaluated in the flume assumes that fish are traveling at the same velocity as the approach flow. Without more reliable data on fish behavior, fish velocity and avoidance coefficients cannot be incorporated into the theoretical model for predicting turbine passage survival. This type of information should be a focus of future research in order to develop total project passage survival rates. Also, the models presented in this report describe the prediction of strike probability and mortality and overall turbine passage survival only for fish that pass through the blade sweep of turbine (i.e., the probability that fish will encounter a turbine or avoid entrainment if they do, are not factored into the theoretical models).

With respect to design and operation, there are several factors that will affect strike probabilities associated with fish passage through hydrokinetic turbines. Because increases in blade speed associated with increases in approach velocity will typically be linear, and because strike probability decreases with increased approach flow (and fish) velocity and increases with increased blade speed, these factors offset each other, and strike probabilities will remain constant across the range of approach velocities that most hydrokinetic turbines will operate. However, strike mortality will increase with approach velocity due to greater injury associated with higher strike speeds. Also, for axial flow turbines, strike probability will remain relatively constant from the hub to the blade tip because, despite increasing blade speeds with distance from the hub, the gap between blades increases towards the tip. Similar to the effects of increasing approach velocities, strike mortality will increase with distance from the hub because blade (strike) speed increases linearly from the hub to the tip.

As determined by blade strike studies, the ratio of fish length to blade thickness will also affect strike mortality rates, with lower ratios resulting in less injury (EPRI 2008). Consequently, the primary factors affecting turbine passage survival of fish passing through hydrokinetic turbines will be approach velocity (and resulting blade speed), location of passage (near hub, mid, or tip regions), fish length, and leading edge blade thickness. As discussed previously, when more information becomes available on the actual speed of fish as they pass through a hydrokinetic turbine and potential for fish to actively avoid blade strike, coefficients that describe these parameters may be developed and incorporated into theoretical blade strike probability models. In the mean time, strike probabilities using the theoretical approach described here should be considered conservative.

Based on the methods and data developed from studies of fish passage through conventional hydro turbines, we present a model (and its assumptions) for predicting strike probability and mortality and total turbine passage survival for fish passing through the two hydrokinetic turbine designs (LST and Welka UPG) that were evaluated with fish during flume studies (Chapter 3).

Strike Probability and Mortality Model

The probability that a fish will be struck by a turbine blade is a function of the distance that blade leading edges move, compared to the total distance between two consecutive leading edges, in the time it takes a fish to be carried or swim past the arc of leading edge motion (Figure 4-4). Consequently, the probability of strike is given by the following equation (Ploskey and Carlson 2004, Hecker and Allen 2005):

$$P_s = n [L \sin \alpha] N / 60 V_r \text{ (dimensionless) (1)}$$

where:

P_s = probability of strike

n = runner rpm

N = number of leading edges (blades)

L = fish length

α = angle of absolute inflow

V_r = radial component of inflow velocity

Note that α is the angle between the absolute inflow velocity and a tangent line to the runner circumference (Figure 4-4). The parameter $L \sin \alpha$ is the projected fish length in the axial (or radial) direction.

For the purposes of our analysis, fish are assumed to orient with their body length parallel to the ambient current, which is considered typical behavior when fish are moving in fast currents. Rheotactic behavior (i.e., whether fish are oriented head or tail first relative to flow direction) may vary, but observations at dams indicate fish will exhibit positive rheotaxis (head facing upstream) when approaching objects or zones of rapidly increasing water velocities. Side to side movement may occur in front of a turbine and fish may turn (to head facing downstream) as they pass into a region of rapid flow acceleration. The assumption that fish are oriented parallel with the flow as they pass through a hydrokinetic turbine is a conservative one, because it takes more time for the total fish length to pass between the moving blades and injury potential would likely be less if fish were angled less than 90 degrees to a turbine blade (EPRI 2011b).

Mortality due to strike is determined by multiplying P_s by a coefficient K based on experimental data for the proportion of fish that are killed after being struck by a blade. From blade strike tests under controlled conditions (Hecker et al. 2007; Amaral et al. 2008; and EPRI 2008), we have determined that K varies with the relative water to blade velocity (i.e., strike velocity) and the ratio of fish length to leading edge blade thickness (L/t).

For the purposes of the analysis of turbine passage survival, we use K values derived from blade strike tests conducted with rainbow trout. The following is Equation 1 with the inclusion of the coefficient K :

$$P_{sm} = Kn [L \sin \alpha] N / 60 V_r \text{ (dimensionless) (2)}$$

where:

P_{sm} = probability of mortality from blade strike

Using Equation 2, an estimate of turbine passage survival ($1 - P_{sm}$), based on blade strike injury only, can be generated for fish passing through the blade sweep of most hydrokinetic turbine designs. The adaptation of this model to the two turbines evaluated with fish in Alden's large flume test facility is presented below.

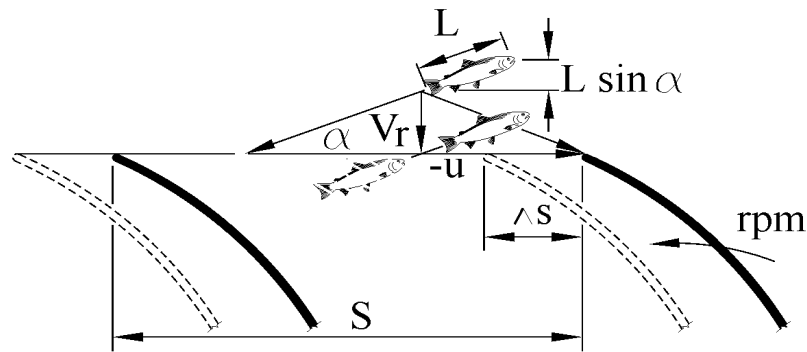

Figure 4-1

Absolute inflow, axial (or radial) component and relative velocity to blade. The parameter Δs is the incremental blade motion in the time fish move through the leading edge circumference.

Application of Strike Model to Lucid Spherical Turbine

Model Parameters and Assumptions

The Lucid spherical turbine is designed for open water and in-line pipe or conduit applications. Our analysis was conducted for the full-size turbine model that was tested with fish in the Alden large flume test facility. The following turbine design and operation parameters were used to estimate strike probability and mortality of fish passing through the LST operating at the three approach velocities, of which the two lower velocities were evaluated during flume testing with fish:

- Approach velocities 1.5, 2.1, and 3.0 m/s (5, 7, and 10 ft/s)
- Runner rotational speeds, n 63.7, 89.2, and 127.4 rpm
- Blade tip radius at vertical centerline 0.57 m (1.88 ft)
- Runner diameter at vertical centerline 1.14 m (3.75 ft)

- Blade tip radius at quarter height 0.52 m (1.71 ft)
- Runner diameter at quarter height 1.04 m (3.42 ft)
- Number of blades, N 4
- Blade leading edge thickness, t 19 mm (0.75 in)

The absolute velocity immediately upstream of the blade leading edges, V_a , is equal to the ambient water velocity. Vector addition of the absolute velocity and the (negative) blade leading edge speed (which depends on the distance from the center of rotation) gives the relative velocity (speed and direction) of the flow to the blade (Figure 4-2 and Figure 4-3). The relative velocity is the speed at which the fish strike the leading edge of the blade.

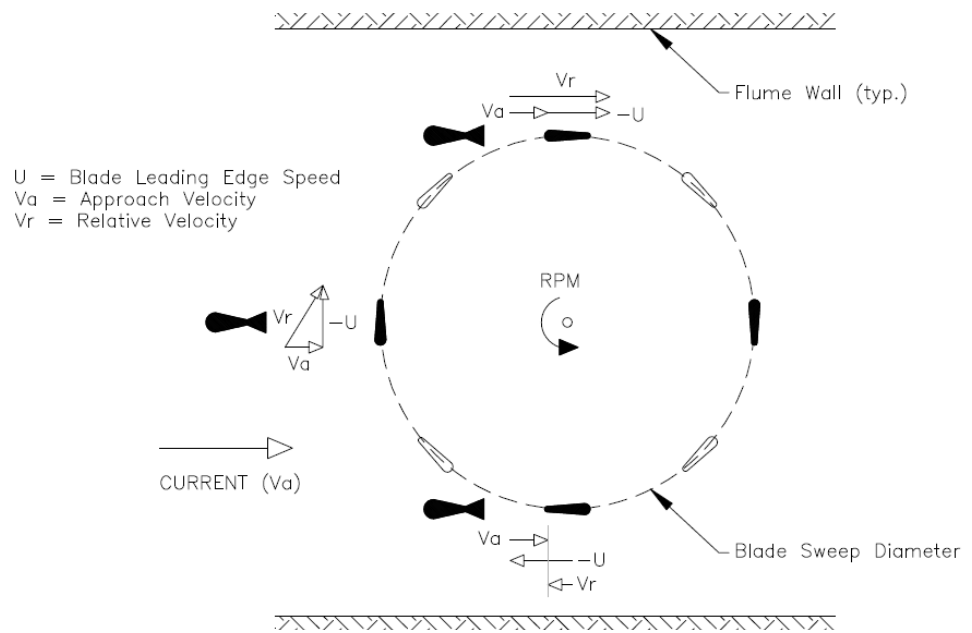

Figure 4-2
Schematic plan view of fish approach locations and corresponding velocity vectors for the Lucid spherical turbine

The blade speed can be calculated from:

$$u = 2\pi rn/60 \quad (3)$$

where:

u =blade speed

r =radius from center of rotation to the leading edge

n =rpm

The mortality coefficient K was derived from data reported by EPRI (2008) that describes the relationship between strike mortality and relative water to blade velocity (i.e., strike velocity) and the ratio of fish length to leading edge blade thickness. The blade thickness at the leading edge for the LST was determined by measuring the physical properties of the lab-tested turbine and then fitting a circle within the actual shape of the leading edge. The diameter of that circle was determined to be 1.9 cm (0.75 inches).

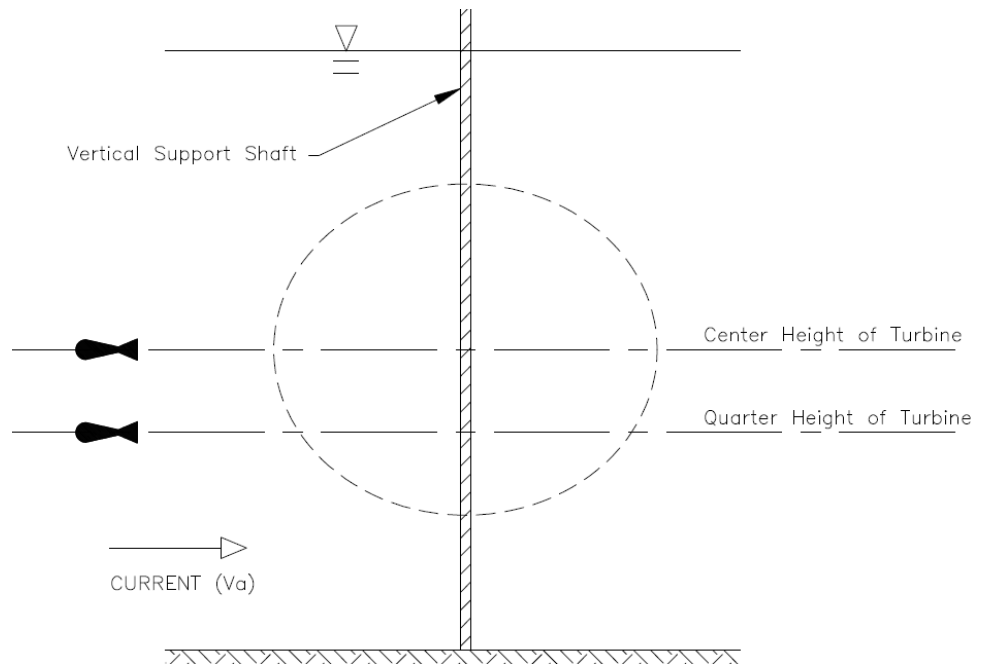

*Figure 4-3
Schematic elevation view of fish approach locations and corresponding velocity vectors for the Lucid hydrokinetic turbine*

At each approach velocity (and corresponding rotational speed), the probability of strike and mortality due to strike were calculated for fish lengths ranging from 50 to 600 mm. This range encompasses the vast majority of fish (species and life stages) that are likely to encounter hydrokinetic turbines in most flowing water environments, and it represents the ratios of fish length to blade thickness for which mortality data have been developed in lab studies (EPRI 2008). For the LST, it was determined that strike mortality will not occur at ambient current velocities less than 1.7 m/s for the range of fish lengths assessed because resulting strike velocities are not sufficient to cause injury [i.e., strike velocities will be less than about 4.5 m/s (15 ft/s), above which strike-related mortality may begin to occur (EPRI 2008, 2011b), depending on fish length and leading edge blade thickness]. Because the LST is a cross flow design with an enclosed spherical shape, fish that pass through the blade sweep to the interior will pass through the blade sweep a second time when they exit. Therefore, in addition to estimates of strike probability and mortality for a single pass through the blade sweep, turbine passage survival was calculated for two passes through the turbine blade sweep, where two passes represents fish entering and exiting a turbine. It was assumed

that fish moving out of the interior of the turbine will be perpendicular to the blade motion (as during entry) and the approach and relative (strike) velocities are the same as when fish enter the upstream portion of the blade sweep.

Strike probability and mortality were calculated for fish passing through the blade sweep at locations on the upstream face where the vertical and horizontal centerlines meet and at half the distance along a blade between the horizontal centerline and the top (or bottom) of the turbine (Figure 4-2 and Figure 4-3). Using the installation of the LST in Alden's large flume test facility (Chapter 2) as an example, the relative (fish to blade) velocity is highest where the fish and blades are moving in exactly opposite directions (fish moving downstream and blade moving upstream parallel to flow) (Figure 4-2). However, the length of the fish exposed to a blade ($L\sin\alpha$) at this location is the shortest it can be relative to being struck by a blade. The lowest relative velocity occurs where fish and blades are moving in the same direction (downstream), which also has the shortest fish exposure length. The two locations of fish passing through the blade sweep selected for our calculations represent a strike speed that is an approximate average of the highest and lowest speeds at each of the two vertical positions (i.e., vertical/horizontal midpoint and half the distance between this location and the top/bottom of the turbine, also referred to as quarter height) (Figure 4-3). These positions also represent where the maximum exposure length of the fish to a blade will occur if fish are oriented parallel to the flow (i.e., the angle of fish relative to an approaching blade is perpendicular), which was assumed for the model predictions. It was also assumed that fish will be perpendicular to the blade at the point of impact with a relative velocity close to the blade speed. Fish leaving the interior portion of the turbine may exit at any direction from the hub. However, for simplicity, it was assumed that fish moving out of the interior will be perpendicular to the blade motion.

Turbine Passage Survival Estimates

As expected, the predicted strike probability associated with the Lucid spherical turbine increases with fish size (Figure 4-4). However, observations from flume testing indicated that strike probability for entrained fish was greater for the larger of the two size groups tested (see Table 3-5), as well as being higher than predicted by the theoretical model for both size groups. These results suggest that larger fish may have had greater ability to avoid blade strike, but that both size groups were more susceptible to blade strike than would be predicted by the theoretical model. For any given fish length, predicted strike probability does not change with approach velocity or the location of fish entry into the blade sweep in the vertical plane because the changes in the speed of fish passing through the turbine at different approach velocities are proportional to corresponding changes in blade velocity (Table 4-1 and Table 4-2). That is, as the ambient current velocity increases, the velocity of approaching fish and the blades increase proportionally, resulting in no change in strike probability within the range of current velocities that the turbine is expected to operate.

Also, with respect to vertical location of entry into the blade sweep, strike probability does not change because the narrower distance between blades at the quarter point is offset by a slower blade speed compared to the midpoint location (i.e., location of maximum diameter and blade speed). Strike probability through the LST blade sweep is predicted to be 100% when fish length exceeds 350 mm (Figure 4-4).

The predicted mortality for fish struck by a blade also increases with fish size, as well as approach velocity (Figure 4-5; Table 4-1 and Table 4-2). Strike mortality begins to occur at an ambient current velocity of about 1.7 m/s when the strike velocity (relative velocity of fish to blade) is of a sufficient magnitude (greater than about 5 m/s) to cause fatal injuries to fish with lengths that are greater than the thickness of the leading edge of the blades. Strike mortality also increases with fish speed for any given fish length and approach velocity due to corresponding increases in strike velocity.

Predicted turbine passage survival for single and double passes through the blade sweep decreases with increases in fish size and ambient current velocity based upon the estimated strike probability and mortality rates (Figure 4-6; Table 4-1 and Table 4-2). With respect to the effect of fish entry location relative to the vertical plane, passage survival increases as fish move away from the turbine centerline at the same current velocity. Mortality decreases because the turbine diameter decreases above and below the turbine centerline, resulting in a reduced blade speed and therefore a lower strike velocity. As current velocities begin to exceed 1.7 m/s, turbine passage survival begins to decrease primarily for larger fish, but generally remains high (greater than 90%) for fish less than 200 mm in length.

The theoretical estimates of turbine passage survival and the survival estimates calculated from the flume data cannot be directly compared because the flume estimates include fish that avoided turbine passage. However, the flume data indicated survival for all fish, including those that passed through the blade sweep of the LST, was 100% at an approach velocity of 1.5 m/s. This is consistent with the theoretical predictions of turbine passage survival for this approach velocity and supports the conclusion that fish of these species and sizes that are struck by turbine blades at strike velocities less than about 5 m/s will not sustain fatal injuries (strike velocity on the centerline of the LST is about 4.1 m/s at an approach velocity of 2.1 m/s). Total survival of fish tested in the flume at a velocity of 2.1 m/s was 99.0 and 98.4% for the smaller and larger-sized fish (mean lengths of 138 and 249 mm), respectively, both of which are higher estimates of survival than theoretical predictions. The differences between empirical and theoretical data at this velocity reflect the ability of fish to avoid turbine passage in the flume. Experimental and theoretical estimates of survival would be more comparable if the experimental data were sufficient to only include fish entrained through the blade sweep calculation of turbine passage survival rates. These observations highlight the limitations of theoretical models of hydrokinetic turbine-fish interactions that do not account for avoidance and evasion behavior.

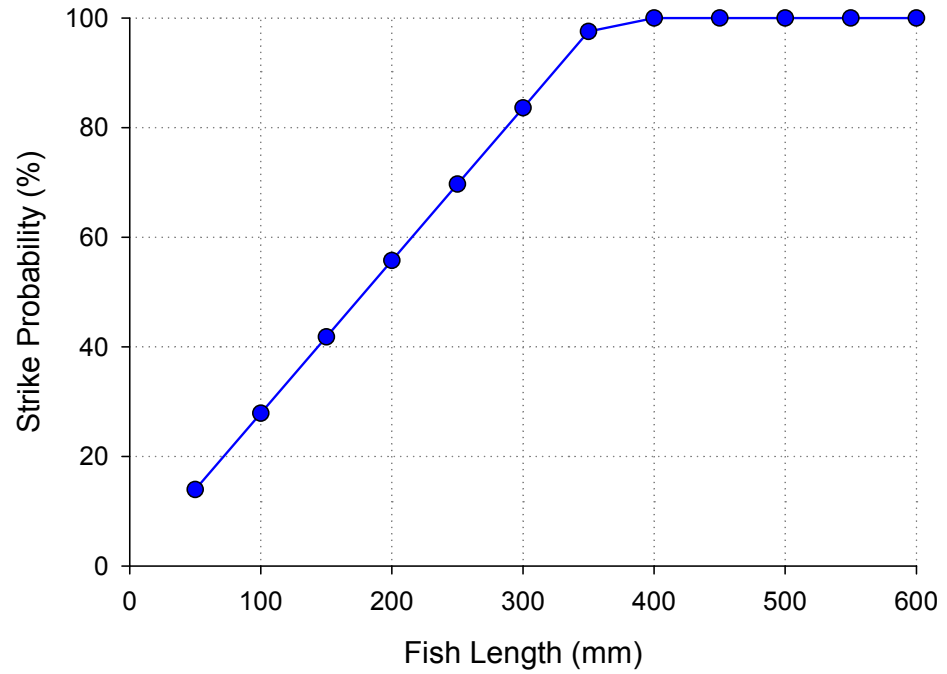

Figure 4-4
Strike probability versus fish length for a single pass through the blade sweep of a Lucid spherical turbine with fish approaching the turbine at the same speed as the flow. For any given fish length, strike probability is the same for all flow approach velocities and for all strike locations along a blade (i.e., strike probability at the mid and quarter blade points will be the same).

Table 4-1

Summary of blade strike probability, predicted strike mortality, and predicted turbine passage survival for a Lucid spherical turbine operated at three current velocities with fish passing through at the blade midpoint. Turbine passage survival is presented for fish passing through the blade sweep once and twice (i.e., entry into and exit from turbine).

Fish Length (mm)	Strike Probability for All Current Velocities (%)	Strike Mortality (%)			Turbine Passage Survival (%) for Single Pass through Blades			Turbine Passage Survival (%) for Double Pass through Blades		
		1.5 m/s	2.1 m/s	3.0 m/s	1.5 m/s	2.1 m/s	3.0 m/s	1.5 m/s	2.1 m/s	3.0 m/s
50	13.9	0.0	8.9	26.5	100.0	98.8	96.3	100.0	97.5	92.8
100	27.9	0.0	13.6	40.3	100.0	96.2	88.8	100.0	92.6	78.8
150	41.8	0.0	16.3	48.4	100.0	93.2	79.8	100.0	86.9	63.6
200	55.7	0.0	18.2	54.1	100.0	89.9	69.8	100.0	80.7	48.8
250	69.7	0.0	19.7	58.6	100.0	86.3	59.2	100.0	74.4	35.0
300	83.6	0.0	20.9	62.2	100.0	82.5	48.0	100.0	68.1	23.0
350	97.5	0.0	22.0	65.3	100.0	78.6	36.3	100.0	61.8	13.2
400	100.0	0.0	22.8	67.9	100.0	77.2	32.1	100.0	59.5	10.3
450	100.0	0.0	23.6	70.3	100.0	76.4	29.7	100.0	58.3	8.8
500	100.0	0.0	24.3	72.4	100.0	75.7	27.6	100.0	57.2	7.6
550	100.0	0.0	25.0	74.3	100.0	75.0	25.7	100.0	56.3	6.6
600	100.0	0.0	25.6	76.0	100.0	74.4	24.0	100.0	55.4	5.7

Table 4-2

Summary of blade strike probability, predicted strike mortality, and predicted passage survival for a Lucid spherical turbine operated at three current velocities with fish passing through the blade quarter point. Turbine passage survival is presented for fish passing through the blade sweep once and twice (i.e., entry into and exit from turbine).

Fish Length (mm)	Strike Probability for All Current Velocities (%)	Strike Mortality (%)			Turbine Passage Survival (%) for Single Pass through Blades			Turbine Passage Survival (%) for Double Pass through Blades		
		1.5 m/s	2.1 m/s	3.0 m/s	1.5 m/s	2.1 m/s	3.0 m/s	1.5 m/s	2.1 m/s	3.0 m/s
50	13.9	0.0	5.8	22.1	100.0	99.2	96.9	100.0	98.4	93.9
100	27.9	0.0	8.8	33.6	100.0	97.5	90.6	100.0	95.1	82.2
150	41.8	0.0	10.6	40.3	100.0	95.6	83.1	100.0	91.3	69.1
200	55.7	0.0	11.9	45.1	100.0	93.4	74.9	100.0	87.2	56.0
250	69.7	0.0	12.9	48.8	100.0	91.0	66.0	100.0	82.9	43.6
300	83.6	0.0	13.7	51.8	100.0	88.6	56.7	100.0	78.5	32.1
350	97.5	0.0	14.3	54.4	100.0	86.0	46.9	100.0	74.0	22.0
400	100.0	0.0	14.9	56.6	100.0	85.1	43.4	100.0	72.4	18.8
450	100.0	0.0	15.4	58.6	100.0	84.6	41.4	100.0	71.5	17.2
500	100.0	0.0	15.9	60.3	100.0	84.1	39.7	100.0	70.7	15.7
550	100.0	0.0	16.3	61.9	100.0	83.7	38.1	100.0	70.0	14.5
600	100.0	0.0	16.7	63.3	100.0	83.3	36.7	100.0	69.4	13.4

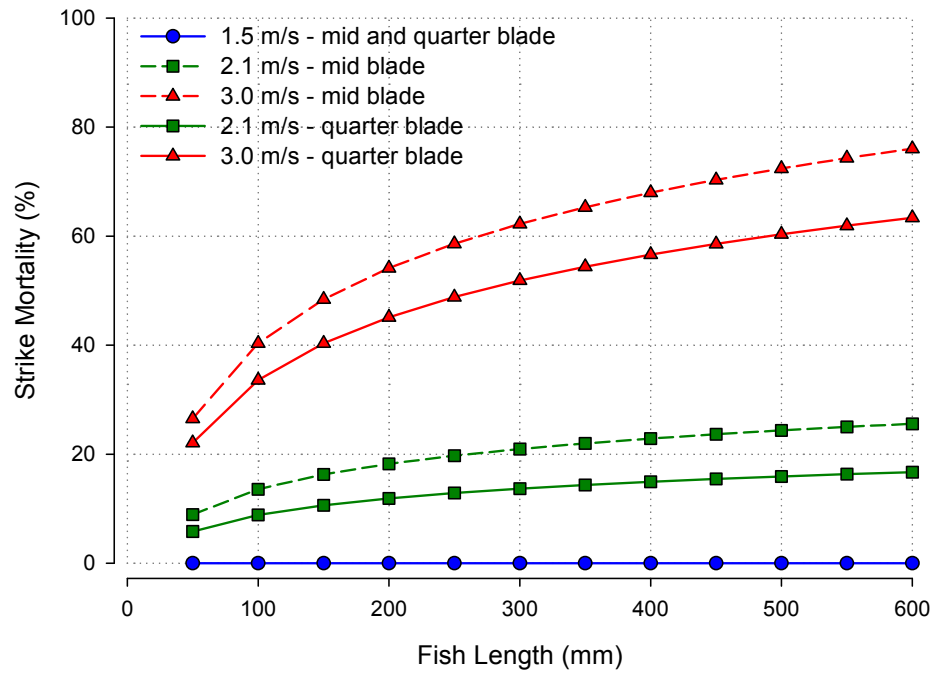

Figure 4-5
 Predicted strike mortality (i.e., probability a fish is killed if struck by a blade) for fish passing through the LST blade sweep once at three approach velocities (i.e., fish speed equals flow speed) and two vertical locations (mid and quarter blade).

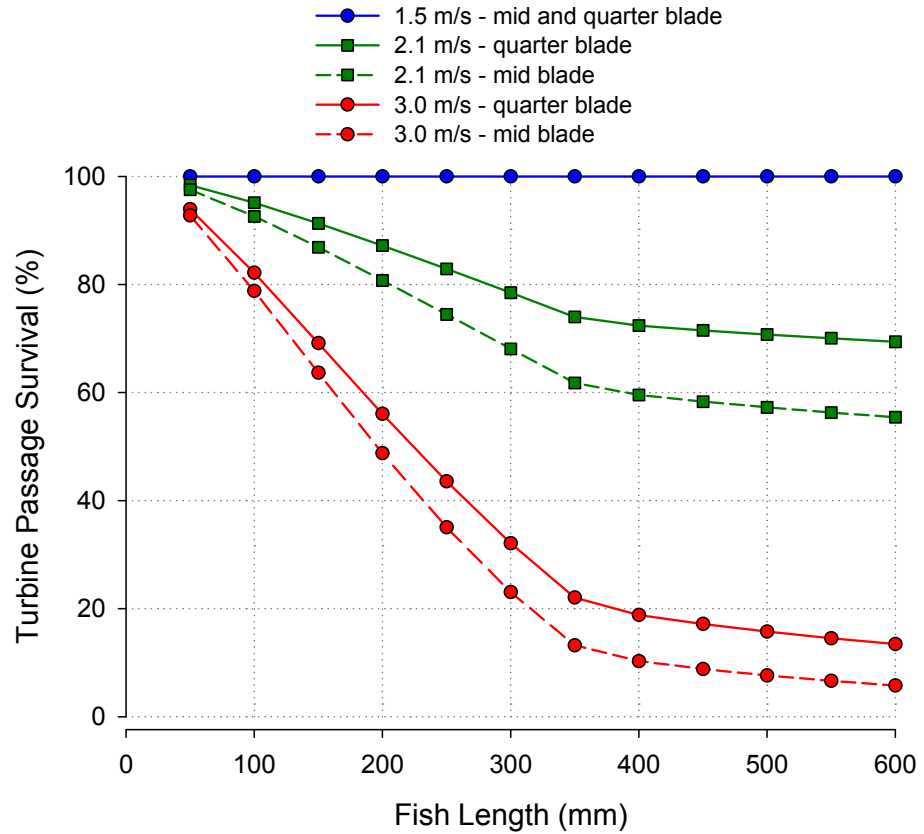

Figure 4-6
 Predicted turbine passage survival (combining strike probability and strike mortality) for fish up to 600 mm in length passing through the LST at three approach velocities (i.e., fish speed equals flow speed) and two vertical locations (mid and quarter blade). Survival rates account for fish passing through the blade sweep twice.

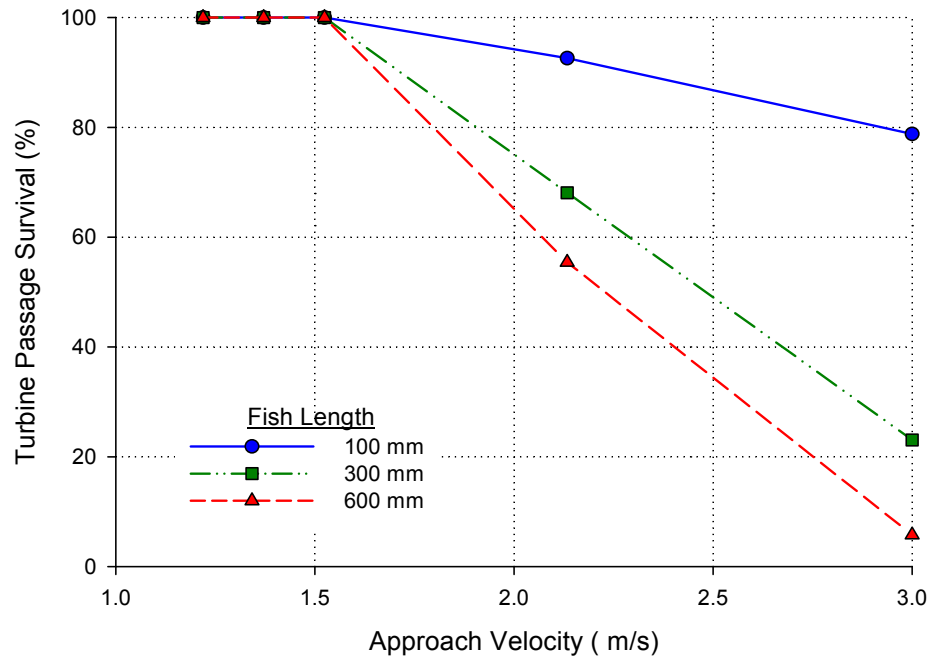

Figure 4-7
 Turbine passage survival rates (combining strike probability and strike mortality) versus ambient current velocity for different lengths of fish. These estimates are based on the assumption that fish are approaching a turbine at the same speed as the ambient current and they pass through the blade sweep twice.

Application of Strike Model to the Welka UPG Turbine

Model Parameters and Assumptions

The following turbine design and operation parameters were used to estimate strike probability and mortality of fish passing through the Welka UPG turbine at the two approach velocities evaluated during flume tests:

- Approach velocities 1.5 and 2.1 m/s (5 and 7 ft/s)
- Runner rotational speed, n 15 and 35 rpm
- Blade tip radius at blade tip 0.76 m (2.50 ft)
- Runner diameter at blade tip 1.52 m (5.00 ft)
- Blade tip radius at mid-bladelength 0.38 m (1.25 ft)
- Runner diameter at mid-blade length 0.76 m (2.5 ft)
- Number of blades, N 4
- Blade leading edge thickness, t 12.7 mm (0.5 in)

The absolute velocity immediately upstream of the blade leading edges, V_a , is equal to the ambient water velocity. Vector addition of the absolute velocity and the (negative) blade leading edge speed (which depends on the distance from the

center of rotation) provides the relative velocity (speed and direction) of the flow to the blade (Figure 4-8). The relative velocity is the speed at which the fish strike the leading edge of the blade.

The blade speed at the radius of interest can be calculated from:

$$u = 2\pi rn/60 \quad (3)$$

where:

u =blade speed (ft/s)

r =radius from center of rotation a point on the leading edge (ft)

n =rpm

The mortality coefficient K was derived from data reported by EPRI (2008) that describes the relationship between strike mortality and relative water to blade velocity (i.e., strike velocity) and the ratio of fish length to leading edge blade thickness. The blade thickness at the leading edge for the Welka UPG turbine was determined by measuring the physical properties of the lab-tested turbine and then fitting a circle within the actual shape of the leading edge. The diameter of that circle was determined to be 0.5 inch.

At each approach velocity (and corresponding rotational speed), the probability of strike and mortality due to strike were calculated for fish lengths ranging from 50 to 600 mm passing through the blade sweep at the blade midpoint and tip. The selected length range encompasses the vast majority of fish (species and life stages) that are likely to encounter hydrokinetic turbines in most flowing water environments, and it represents the ratios of fish length to blade thickness for which mortality data have been developed in laboratory studies (EPRI 2008). For the Welka UPG, it was determined that strike mortality will not occur at ambient current velocities less than 2.5 m/s for the range of fish lengths assessed because resulting strike velocities are not sufficient to cause injury [i.e., strike velocities will be less than about 5 m/s, above which strike-related mortality may begin to occur (EPRI 2008), depending on fish length and leading edge blade thickness].

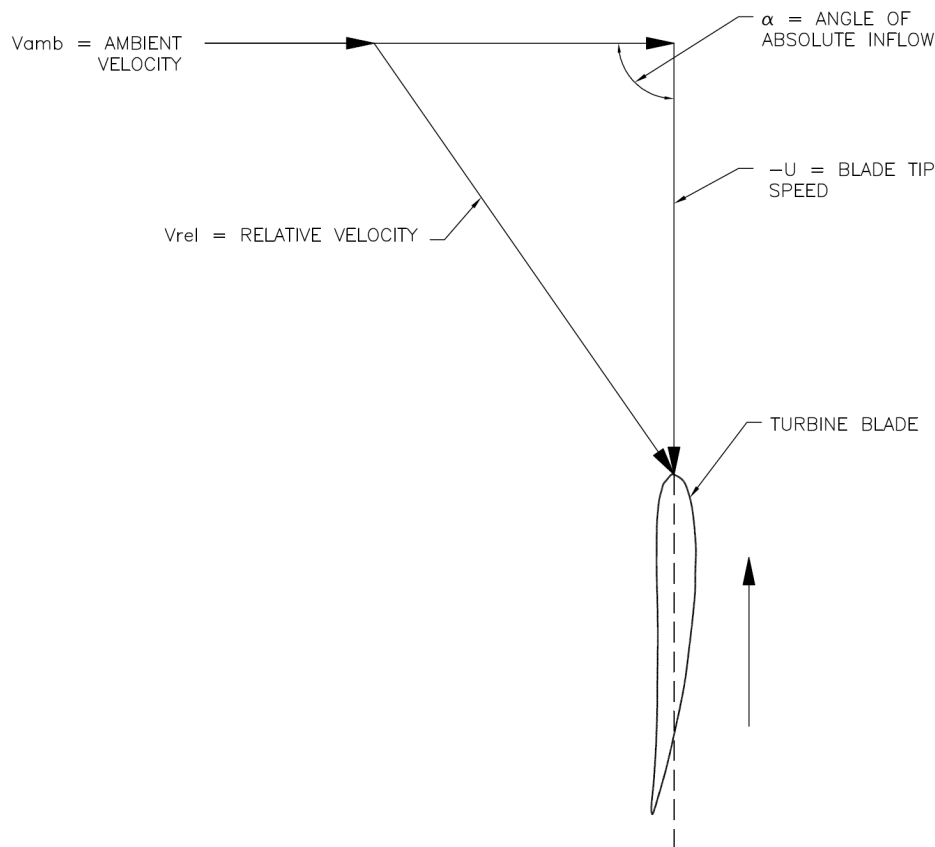

Figure 4-8
Velocity vector triangle for the Welka UPG hydrokinetic turbine

Turbine Passage Survival Estimates

Strike probability estimates for fish passing through a Welka UPG turbine increase with fish length and are the same for all ambient current velocities and strike locations along a blade for a given length (Table 4-3). Strike probability only varies with fish size because increases in blade speeds with distance from the hub are proportional to the wider spacing between blades, and because fish pass through the turbine more quickly as approach velocity (and blade speed) increase. For fish 600 mm in length and less, strike mortality is not predicted to occur during passage through a Welka UPG turbine at ambient current velocities less than about 2.5 m/s because strike velocities will not exceed 5 m/s, which is the approximate upper limit above which fish mortality will begin to occur [depending on the ratio of fish length to blade thickness; EPRI (2008)]. Consequently and as estimated, predicted turbine passage survival will be 100% for fish that pass through a Welka turbine over the entire blade length at an ambient current of 2.5 m/s or less. Also, the theoretical estimates are consistent with the experimental results from flume testing (99.4 to 100%). Note, however, that both the experimental apparatus and the theoretical model assumptions precluded turbine avoidance by the fish; turbine avoidance is an important factor when fish are not forced through the turbine.

Table 4-3

Estimated blade strike probability and predicted survival rates for fish of various sizes passing through the Welka UPG turbine at two ambient current velocities and blade locations

Fish Length (mm)	Blade Strike Probability (%)	Turbine Passage Survival (%)			
		1.5 m/s		2.1 m/s	
		Mid	Tip	Mid	Tip
50	5.5	100.0	100.0	100.0	100.0
100	10.9	100.0	100.0	100.0	100.0
150	16.4	100.0	100.0	100.0	100.0
200	21.9	100.0	100.0	100.0	100.0
250	27.3	100.0	100.0	100.0	100.0
300	32.8	100.0	100.0	100.0	100.0
350	38.3	100.0	100.0	100.0	100.0
400	43.7	100.0	100.0	100.0	100.0
450	49.2	100.0	100.0	100.0	100.0
500	54.7	100.0	100.0	100.0	100.0
550	60.1	100.0	100.0	100.0	100.0
600	65.6	100.0	100.0	100.0	100.0

Section 5: Conclusions and Discussion

The information and data developed from this research effort has resulted in a better understanding of the interactions between fish and hydrokinetic turbines for two general design types (vertical cross-flow and ducted axial flow). However, the ability to apply the study results to other turbines will depend, in part, on differences in design and operation (e.g., blade shape and spacing, number of blades, rotational speeds) compared to the two turbines that were evaluated as part of the current study. Regardless of turbine differences, the observations of fish behavior, particularly avoidance at a very close distance to moving blades, provide strong evidence as to how fish are likely to react when approaching a wide range of hydrokinetic turbine designs in the field.

The estimation of turbine passage survival using flume data and theoretical models presented in this report only accounts for direct mortality resulting from lethal injuries sustained during passage through the two turbines evaluated. Increased stress and sub-lethal injuries may also occur during turbine passage and can lead to indirect (or delayed) mortality associated with reduced fitness and greater susceptibility to disease and predation (Budy et al. 2002; Ferguson et al. 2006). Indirect mortality can be more difficult to evaluate and quantify than direct mortality, but some longer term tagging studies have examined the indirect effects of turbine passage on survival rates associated with downstream movement through one or more conventional hydro projects. Although evaluations of indirect mortality can only be evaluated in the field for fish passing through conventional hydro turbines, future lab studies may be able to examine this parameter in more detail for hydrokinetic turbines.

The following are the primary conclusions from the biological evaluation of the LST and the theoretical estimation of strike probability and mortality:

Immediate and total survival rates of rainbow trout encountering the Lucid spherical turbine were greater than 99% for both size classes and velocities tested, with the exception of 250-mm fish evaluated at the higher velocity (2.1 m/s), for which total survival was 98.4%. These survival rates represent fish that passed downstream by actively avoiding entrainment and those that were entrained through the operating unit. Because the LST is a cross-flow design, fish that were entrained passed through the blade sweep twice.

Injury and scale loss rates for rainbow trout encountering the LST were negligible based on the rates observed for control fish released downstream of the turbine (i.e., most injury and scale loss was attributed to pre-test condition of fish and/or handling and testing procedures, not passage around or through the turbine).

Despite exiting the release system within 250 to 300 mm (about 10 to 12 inches) of the upstream face of the turbine blade sweep, observations from underwater video demonstrated that many treatment fish actively avoided entrainment through the LST by swimming to the sides, top, or bottom of the operating turbine. A review of the underwater video indicated between about 82 and 94% of rainbow trout avoided passage through the turbine in this manner. The lowest estimates of avoidance were recorded at the higher test velocity for both size groups of trout.

Behavioral tests, in which rainbow trout were released about 7.6 m (25 ft) upstream from the LST, indicated that most, if not all, fish moving downstream in the 8-ft by 8-ft test channel did not encounter the turbine either through active avoidance or downstream movement along the channel walls or floor.

The theoretical predictions of blade strike probability and mortality of fish passing through the blade sweep of the LST twice (i.e., into and out of the turbine) indicate that turbine passage survival could be relatively low (13 to 90% depending on fish length) at approach velocities of 2.1 m/s and higher.

The experimental data from flume tests indicated survival was higher than predicted by the models. This is because a large proportion of fish were able to avoid turbine passage during flume tests. This highlights the limitations of the theoretical models, which do not incorporate avoidance behavior by the fish. Survival estimates based solely on fish that passed through the LST likely would be comparable to the theoretical predictions.

Based on these conclusions, little, if any, mortality, injury, and scale loss are expected to occur for fish encountering an LST in an open water environment (i.e., riverine or tidal). However, for pipe or conduit installations of the LST at sites where fish can be entrained with the intake flow and will have to pass through the blade sweep twice, the theoretical predictions indicate that mortality could be high under certain operational conditions (approach velocities greater than 1.5 m/s) for fish greater than about 100 mm (4 inches). Consequently, pipe or conduit applications may require protective screening to minimize fish entrainment and resulting turbine passage mortality.

The primary conclusions from testing with the Welka UPG turbine and the theoretical estimates of blade strike probability and mortality include:

Immediate and total turbine passage survival for the two size groups of rainbow trout and largemouth bass evaluated at approach velocities of 1.5 and 2.1 m/s were greater than 99.5%.

Based on control fish data, observed injury and scale loss for turbine-passed fish can primarily be attributed to the pre-test condition of fish and/or handling and testing procedures.

Underwater video observations during survival testing with the Welka UPG turbine were not reliable due to obstruction of cameras associated with the containment net, the turbine runner duct, and air entrainment in the flume.

Behavioral tests indicated that most, if not all, rainbow trout moving downstream in the 2.4-m by 2.4-m test channel did not encounter the turbine either due to active avoidance or downstream movement along the channel walls or floor. Similar observations were made for largemouth bass.

Theoretical estimates of blade strike probability ranged from about 5 to 60% for fish 50 to 600 mm in length (about 2 to 24 inches) and estimates of strike mortality were 0% for all fish lengths and the two approach velocities evaluated (1.5 and 2.1 m/s). Consequently, turbine passage survival was estimated to be 100% for these fish size and velocity conditions, concurring with the survival estimates developed from the flume tests in which all fish were forced through the turbine.

These conclusions indicate that fish entrained through a Welka UPG turbine will suffer little or no injury and mortality over the likely range of operating conditions (this turbine is designed for operation in relatively low velocities similar to those tested in the flume). The theoretical predictions were consistent with the experimental results from flume testing, suggesting that a predictive model could be used to assess turbine passage survival rates at future installations if they have operational conditions that differ from those tested during the laboratory evaluation. For such field applications, however, additional factors, such as fish movement routes and turbine avoidance would need to be incorporated into the analysis in order to estimate overall passage success.

Despite very precise estimates of turbine passage survival (i.e., confidence intervals typically were less than $\pm 2\%$ of the survival estimates), only a few statistically significant differences were detected when comparing the survival data among treatments. For the LST, total survival was significantly greater for larger rainbow trout tested at the lower velocity (1.5 m/s) than at the higher velocity (2.1 m/s). This was mainly due to a higher rate of delayed mortality (48-hr) at the faster velocity and could be indicative of increased mortality associated with greater strike speeds (strike velocities are sufficient to result in some mortality when approach velocities to the LST exceed 1.7 m/s). The only other statistical difference in survival rates that was detected occurred with rainbow trout tested at a velocity of 2.1 m/s during tests with the Welka UPG. At this velocity, the smaller trout had significantly higher immediate and total survival than the larger fish. However, this statistical significance was mainly due to the survival estimates for the smaller fish exceeding 100% (i.e., mortality was higher for control fish than it was for treatment fish). In fact, if survival estimates are capped at 100% for tests with both turbines when control mortality exceeded that of treatment fish, there would be no significant differences among the

treatments for any of the tests with each unit. The lack of significant differences in treatment conditions reflects the high and narrow ranges of the survival estimates that occurred among all of the treatments. To some extent, the lack of statistically significant differences may also have been a product of the selected fish sizes and velocities over which tests with each turbine were conducted. In particular, testing with larger or smaller fish and/or faster approach velocities could have produced more significant differences between measured survival rates. Survival data for fish lengths and flow velocities greater than those tested as part of the current would only be useful for sites where larger fish and faster velocities are expected to occur. Future lab testing could be conducted to address this potential information gap and broaden the current dataset. Conversely, survival rates for smaller fish and lower approach velocities may be similar or higher than those observed in the Alden flume studies.

To date, only one other study has been completed that was specifically designed to estimate direct survival of fish passing through a hydrokinetic turbine. This study was conducted in the field with an axial-flow ducted propeller turbine developed by Hydro Green Energy (NAI 2009). The Hydro Green turbine was installed in the tailrace of an operating conventional hydro project and evaluated with several species and life stages of fish using a release-recapture methodology (i.e., fish were introduced into the turbine duct upstream of the blades and recovered following passage after balloon tags attached to the musculature of each fish inflated and brought them to the surface). The results of this study indicated total (48-hr) survival rates were 99% for yellow perch (118-235 mm in length), bluegill (115-208 mm), channel catfish (451-627 mm), and smallmouth and bigmouth buffalo (388-710 mm). These survival rates are similar to the estimates for rainbow trout and largemouth bass evaluated with the ducted Welka UPG turbine, and are most likely the result of a low strike probability (due to low rotational speed and only three blades) and strike velocity (relative velocity of fish to blade, assuming fish are traveling at the speed of the flow). The tip speed of the Hydro Green turbine was estimated to be about 4 m/s based on a diameter of 3.7 m and rotational speed of 21 rpm. Strike velocity will be higher than the tip speed, but for the Hydro Green turbine it probably was about the same or less than the velocity at which strike mortality begins to occur (4.5 m/s, depending on the ratio of fish length to blade leading edge thickness) over most of the blade leading edge from the hub to the tip. The maximum strike velocity of the Welka UPG, which has 4 blades, was 3.5 m/s. The lab and field tests with these axial-flow ducted turbines demonstrate that this design type is likely to cause little or no mortality to entrained fish, particularly when strike velocities are relatively low (about 4.5 m/s or less). The field evaluation of the Hydro Green turbine also demonstrated that survival rates were very high and similar for a relatively wide range of species and over a broad range of fish sizes. The survival estimates for the two size groups of rainbow trout and largemouth bass that were tested during the Alden flume study are consistent with these observations from the field testing.

The results of the flume studies and the predictive modeling provide some important insights into how fish might react to and be affected by hydrokinetic turbines installed in the field. Both of the turbines that were tested were full-size units (although, the developers of both turbines will likely make available units of varying sizes) and the velocities that were evaluated covered the lower and upper limits of the expected range for field operation for the Welka UPG and included the lower half of the expected design range for the LST (1.2 to 3.0 m/s). Therefore, based on the size of the units and flow velocities tested, the lab results are directly applicable to the operation of these units in field applications (but the actual velocities that both turbines are likely to operate at in the field will vary depending on site-specific conditions). However, fish behavior in a controlled laboratory environment is not always representative to what occurs in natural environments. In particular, avoidance reactions to the turbines in the flume may differ from how fish react to them in the field. The flume data from testing with the LST demonstrate that, even when released very close to an operating turbine, fish will actively avoid passage through the blade sweep. At the two approach velocities tested, video observations indicated that rainbow trout detected the rotating blades, typically maintained positive rheotaxis (head facing upstream), slowed or stopped their downstream movement, and then mainly proceeded around the LST despite the close proximity of their release to the turbine and the relatively confined space of the flume (i.e., a 1.2 m diameter turbine in a 2.4 m deep and wide flow passage). These reactions are typical for fish approaching flow obstructions and/or hydraulic disturbances (Haro et al. 1998) and would be expected to occur at field installations, but avoidance may be even greater in the field because fish will have more time to detect and react to an operating turbine, and would have more space to move around the blade sweep. Also, fish were released on the centerline of the turbine in the flume, whereas in the field, many fish may approach off center and be more likely to follow flow lines around a turbine. On the other hand, under conditions of lower water temperature or reduced visibility, avoidance may be lower, and smaller fish may be less able to avoid the turbine.

The potential for fish to be injured or killed when encountering hydrokinetic turbines in flowing water environments is a major issue that can impede the development of proposed projects and lead to costly field studies. Alteration or blockage of fish movements and migrations also may be an important concern that needs to be addressed. Recently, some field studies have been conducted to examine these types of impacts, but the data collected have not always been sufficient to draw definitive conclusions or are not publicly available. Assessment of the behavior and movement of fish approaching and passing hydrokinetic turbines in the field, including entrainment through blade sweeps and any resulting injuries, is problematic, and the tools and techniques for conducting these types of studies are still being developed and evaluated. The laboratory flume evaluation and application of theoretical blade strike models that were completed as part of the current study, as well as flume testing conducted by the Conte Anadromous Fish Research Laboratory (CAFRL), provide valuable data and information for a better understanding of the outcomes of interactions between fish and hydrokinetic turbines. Quantitative data and visual observations from the laboratory studies clearly demonstrate the outcomes of fish approaching

and passing downstream of hydrokinetic turbines for the turbine designs, flow and operational conditions, and fish species and size classes evaluated. The turbine types and fish species tested may be considered representative of other turbine designs and species based on a comparison of operational conditions and biological characteristics (e.g., swimming abilities, body shape and morphology).

The evidence that a large proportion of fish will avoid passage through hydrokinetic turbines and that overall survival rates will be high for fish that encounter turbines in open water settings is growing. In addition to the observations from the Alden tests, results from flume testing at CAFRL with a Darrieus turbine (cross-flow with straight vertical blades) indicated that Atlantic salmon smolts may avoid turbine passage and that downstream passage survival is likely high (EPRI 2011c). In a recent field study, turbine passage survival for several freshwater species with mean lengths ranging from about 100 to 700 mm (about 4 to 30 inches) was estimated to be 99% for a ducted, axial-flow hydrokinetic turbine (NAI 2009). Individually and collectively, the results from laboratory and field studies suggest that the mortality of juvenile and adult fish passing through hydrokinetic turbines of this design, and perhaps others, will be below levels of concern. However, because the results generally are applicable to passage through a single turbine, more analysis is needed to assess the potential for multiple units to lead to greater mortality rates or impacts on fish movements and migrations. Quantification of avoidance behavior is also needed.

Fish passage through conventional hydro turbines has been extensively studied resulting in a thorough understanding of potential injury mechanisms. In general, turbine passage survival through conventional turbines (excluding Pelton turbines) has been shown to range from about 80 to 95%, depending on turbine design and fish size (Franke et al. 1997). Survival of fish passing through some propeller type turbine designs (e.g., large Kaplans, bulb turbines) may exceed 95%. For many conventional hydro projects, particularly low head sites (less than 30 m), blade strike is considered to be the predominant source of injury and mortality (Franke et al. 1997). This will also be true for hydrokinetic turbines because damaging pressure changes and shear levels are not expected to occur or will be limited in their presence. Also, given that hydrokinetic turbines are not operated under head and hydraulic and mechanical injury mechanisms will be less severe (EPRI 2011a), it is logical to conclude that survival of fish passing through hydrokinetic turbines will be greater than it is for fish passing through conventional hydro turbines. The results of the flume tests described in this report support this conclusion and suggest that survival of fish passing through the blade sweeps of some hydrokinetic devices may be 100% or slightly less depending on design features and operational conditions. When encounter and avoidance probabilities are also considered, overall passage survival rates of 98 to 100% are likely for many turbine designs. Future research should focus on expanding the existing data on potential fish losses associated with hydrokinetic turbine installations by developing better estimates of encounter and avoidance probabilities. Encounter rates could be developed from field monitoring of fish abundance and movements or based on the proportion of river or channel flow that passes through a turbine (or the cross-sectional area of a channel that a turbine's blade sweep occupies (Schweizer *et al.* 2011)). Avoidance probabilities

for fish that encounter a turbine could also be derived from field monitoring, or additional flume testing. These data can then be combined with laboratory or theory-based estimates of turbine passage survival to develop a more comprehensive model that incorporates site-specific hydraulic and environmental conditions to estimate total expected fish losses for single and multiple unit installations. The use of computational fluid dynamics (CFD) modeling may also play an important role in such analyses, particularly if fish behavior can be incorporated.



Section 6: Literature Cited

Amaral, S. V., G. E. Hecker, P. Stacy, and D. A. Dixon. 2008. Effects of leading edge turbine blade thickness on fish strike survival and injury. Proceedings of Hydrovision 2008. HCI Publications, St. Louis, Missouri.

Basham, L. R., M. R. Delarm, J. B. Athern, and S. W. Pettit. 1982. Fish Transportation Oversight Team Annual Report, FY 1981: Transport Operations on the Snake and Columbia Rivers. NOAA Technical Memorandum NMFS F/NNR-2. Environmental and Technical Services Division, Northwest Regional Office, National Oceanic and Atmospheric Administration, National Marine Fisheries Service, Portland, OR.

Budy, P., G. P. Thiede, N. Bouwes, C. E. Petrosky, and H. Schaller. 2002. Evidence linking delayed mortality of Snake River salmon to their earlier hydrosystem experience. *North American Journal of Fisheries Management* 22: 35–51.

Burnham, K. P., D. R. Anderson, G. C. White, C. Brownie, and K. H. Pollock. 1987. Design and Analysis for Fish Survival Experiments Based on Release-Recapture. *American Fisheries Society Monograph* 5.

Čada, G., J. Ahlgrimm, M. Bahleda, T. Bigford, S. Stavrakas, D. Hall, R. Moursund, and M. Sale. 2007. Potential impacts of hydrokinetic and wave energy conversion technologies on aquatic environments. *Fisheries* 32(4): 174–181.

DOE (U.S. Department of Energy). 2009. Report to Congress on the Potential Environmental Effects of Marine and Hydrokinetic Energy Technologies. U.S. Department of Energy, Office of Energy Efficiency & Renewable Energy, Wind and Hydropower Technologies Program, DOE/GO-102009-2955.

DTA (Devine Tarbell & Associates, Inc.). 2006. Instream Tidal Power in North America, Environmental and Permitting Issues. Prepared for the Electric Power Research Institute, Report No. EPRI-TP-007-NA.

EPRI (Electric Power Research Institute). 2008. Evaluation of the effects of turbine blade leading edge design on fish survival. Prepared by Alden Research Laboratory, Inc., EPRI Report No. 1014937.

EPRI (Electric Power Research Institute). 2011a. Fish Passage through Turbines: Applicability of Conventional Hydropower Data to Hydrokinetic Technologies. Prepared by Alden Research Laboratory, Inc. 1024638.

EPRI (Electric Power Research Institute). 2011b. Additional Tests Examining Survival of Fish Struck by Turbine Blades. Prepared by Alden Research Laboratory, Inc. 1024684.

EPRI (Electric Power Research Institute). 2011c (In press). Biological Testing of Effects of EnCurrent Model ENC-005-F4 Hydrokinetic Turbine on Juvenile Atlantic Salmon and Adult American Shad. Prepared by the USGS Conte Anadromous Fish Research Laboratory.

Ferguson, J. W., R. F. Absolon, T. J. Carlson, and B. P. Sandford. 2006. Evidence of delayed mortality on juvenile Pacific salmon passing through turbines at Columbia River Dams. *Transactions of the American Fisheries Society* 135:139–150.

Franke, G. F., D. R. Webb, R. K. Fisher, D. Mathur, P. N. Hopping, P. A. March, M. R. Headrick, I. T. Laczó, Y. Ventikos, and F. Sotiropoulos. 1997. Development of Environmentally Advanced Hydropower Turbine System Concepts. Prepared for the U.S. Department of Energy, Voith Hydro, Inc. Report No. 2677-0141.

Hecker, G. E., and G. S. Allen. 2005. An Approach to Predicting Fish Survival for Advanced Technology Turbines. *Hydro Review*, November 2005, HCI Publications, Inc., St. Louis, Missouri.

Haro, A., M. Odeh, J. Noreika, and T. Castro-Santos. 1998. Behavior and Passage of Atlantic Salmon Smolts and Juvenile American Shad at Surface Bypasses. *Transactions of the American Fisheries Society* 127:118-127.

Hecker, G. E., S. V. Amaral, P. Stacy, and D. A. Dixon. 2007. Developing turbine blades to minimize fish mortality. *Proceedings of Waterpower XV*. HCI Publications, St. Louis, Missouri.

Neitzel, D. A., C. S. Abernethy, E. W. Lusty, and L. A. Prohammer. 1985. A Fisheries Evaluation of the Sunnyside Canal Fish Screening Facility, Spring 1985: Annual Report. U.S. Department of Energy Contract DE-AC06-76RLO 1830.

NAI (Normandeau Associates, Inc.). 2009. An Estimation of Survival and Injury of Fish Passed through the Hydro Green Energy Hydrokinetic System, and a Characterization of Fish Entrainment Potential at the Mississippi Lock and Dam No. 2 Hydroelectric Project (P-4306), Hastings, Minnesota. Prepared for Hydro Green Energy LLC, Houston, Texas.

Ploskey, G. R., and T. J. Carlson. 2004. Comparison of Blade-Strike Modeling Results with Empirical Data. U.S. Department of Energy, Office of Energy Efficiency and Renewable Energy, Wind and Hydropower Technologies, PNNL-14603.

RESOLVE, Inc. 2006. Proceedings of the Hydrokinetic and Wave Energy Technologies Technical and Environmental Issues Workshop. Washington, D.C., October 26-28, 2005. Sponsored by the U.S. Department of Energy.

Schweizer, P. E., G. F. Cada and M. S. Bevelhimer. 2011. *Estimation of the Risks of Collision or Strike to Freshwater Aquatic Organisms Resulting from Operation of Instream Hydrokinetic Turbines*. Oak Ridge National Laboratory. ORNL/TM-2011/133.

Skalski, J. R. 1999. Statistical Input to the Design and Analysis of the ARL/NREC Pilot Scale Fish-Friendly Turbine. Prepared for Alden Research Laboratory, Inc.

Turnpenny, A. W. H., M. H. Davis, J. M. Fleming, and J. K. Davies. 1992. Experimental Studies Relating to the Passage of Fish and Shrimps Through Tidal Power Turbines. Marine and Freshwater Biology Unit, National Power, Fawley, Southampton, England.

Turnpenny, A. W. H., G. Struthers, and P. Hanson. 2000. A UK Guide to Intake Fish-Screening Regulations, Policy and Best Practice with Particular Reference to Hydroelectric Power Schemes. Energy Technology Support Unit, Department of Trade and Industry, Report No. ETSU H/O6/00052/REP.

Von Raben, K. 1957. Regarding the problem of mutilations of fishes by hydraulic turbines. Originally published in *Die Wasserwirtschaft* (100):4:97. Fisheries Research Board of Canada Translation Series No. 448 (1964).

Wilson, B., R.S. Batty, F. Daunt, and C. Carter. 2007. Collision Risks between Marine Renewable Energy Devices and Mammals, Fish and Diving Birds. Report to the Scottish Executive. Scottish Association for Marine Science, Oban, Scotland. PA25 1QA. 110 p.

The Electric Power Research Institute Inc., (EPRI, www.epri.com) conducts research and development relating to the generation, delivery and use of electricity for the benefit of the public. An independent, nonprofit organization, EPRI brings together its scientists and engineers as well as experts from academia and industry to help address challenges in electricity, including reliability, efficiency, health, safety and the environment. EPRI also provides technology, policy and economic analyses to drive long-range research and development planning, and supports research in emerging technologies. EPRI's members represent more than 90 percent of the electricity generated and delivered in the United States, and international participation extends to 40 countries. EPRI's principal offices and laboratories are located in Palo Alto, Calif.; Charlotte, N.C.; Knoxville, Tenn.; and Lenox, Mass.

Together...Shaping the Future of Electricity

Program:

Waterpower

© 2011 Electric Power Research Institute (EPRI), Inc. All rights reserved. Electric Power Research Institute, EPRI, and TOGETHER...SHAPING THE FUTURE OF ELECTRICITY are registered service marks of the Electric Power Research Institute, Inc.

1024569

Survival and Behavior of Juvenile Atlantic Salmon and Adult American Shad on Exposure to a Hydrokinetic Turbine

2012 TECHNICAL REPORT

Survival and Behavior of Juvenile Atlantic Salmon and Adult American Shad on Exposure to a Hydrokinetic Turbine

EPRI Project Manager
P. Jacobson



3420 Hillview Avenue
Palo Alto, CA 94304-1338
USA

PO Box 10412
Palo Alto, CA 94303-0813
USA

800.313.3774
650.855.2121

askepri@epri.com

www.epri.com

1026904

Final Report, December 2012

DISCLAIMER OF WARRANTIES AND LIMITATION OF LIABILITIES

THIS DOCUMENT WAS PREPARED BY THE ORGANIZATION(S) NAMED BELOW AS AN ACCOUNT OF WORK SPONSORED OR COSPONSORED BY THE ELECTRIC POWER RESEARCH INSTITUTE, INC. (EPRI). NEITHER EPRI, ANY MEMBER OF EPRI, ANY COSPONSOR, THE ORGANIZATION(S) BELOW, NOR ANY PERSON ACTING ON BEHALF OF ANY OF THEM:

(A) MAKES ANY WARRANTY OR REPRESENTATION WHATSOEVER, EXPRESS OR IMPLIED, (I) WITH RESPECT TO THE USE OF ANY INFORMATION, APPARATUS, METHOD, PROCESS, OR SIMILAR ITEM DISCLOSED IN THIS DOCUMENT, INCLUDING MERCHANTABILITY AND FITNESS FOR A PARTICULAR PURPOSE, OR (II) THAT SUCH USE DOES NOT INFRINGE ON OR INTERFERE WITH PRIVATELY OWNED RIGHTS, INCLUDING ANY PARTY'S INTELLECTUAL PROPERTY, OR (III) THAT THIS DOCUMENT IS SUITABLE TO ANY PARTICULAR USER'S CIRCUMSTANCE; OR

(B) ASSUMES RESPONSIBILITY FOR ANY DAMAGES OR OTHER LIABILITY WHATSOEVER (INCLUDING ANY CONSEQUENTIAL DAMAGES, EVEN IF EPRI OR ANY EPRI REPRESENTATIVE HAS BEEN ADVISED OF THE POSSIBILITY OF SUCH DAMAGES) RESULTING FROM YOUR SELECTION OR USE OF THIS DOCUMENT OR ANY INFORMATION, APPARATUS, METHOD, PROCESS, OR SIMILAR ITEM DISCLOSED IN THIS DOCUMENT.

REFERENCE HEREIN TO ANY SPECIFIC COMMERCIAL PRODUCT, PROCESS, OR SERVICE BY ITS TRADE NAME, TRADEMARK, MANUFACTURER, OR OTHERWISE, DOES NOT NECESSARILY CONSTITUTE OR IMPLY ITS ENDORSEMENT, RECOMMENDATION, OR FAVORING BY EPRI.

THE FOLLOWING ORGANIZATION, UNDER CONTRACT TO EPRI, PREPARED THIS REPORT:

S.O. Conte Anadromous Fish Research Center

NOTE

For further information about EPRI, call the EPRI Customer Assistance Center at 800.313.3774 or e-mail askepri@epri.com.

Electric Power Research Institute, EPRI, and TOGETHER...SHAPING THE FUTURE OF ELECTRICITY are registered service marks of the Electric Power Research Institute, Inc.

Copyright © 2012 Electric Power Research Institute, Inc. All rights reserved.

Acknowledgments

The following organization, under contract to the Electric Power Research Institute (EPRI), prepared this report:

S.O. Conte Anadromous Fish Research Center
P.O. Box 796, One Migratory Way
Turners Falls, MA 01376

Principal Investigators
T. Castro-Santos
A. Haro

This report describes research sponsored by EPRI.

This material is based upon work supported by the Department of Energy Water Power Program under Award Number DEEE0002659. Additional financial support was received from Canada Department of Fisheries & Oceans and Alaska Energy Authority. We are grateful to New Energy Corporation for providing the Encurrent turbine for the purposes of biological testing.

Constructive comments by Jocelyn Brown-Saracino and her colleagues, U.S. Department of Energy, and by Glenn Cada, Oak Ridge National Laboratory strengthened this report. We also thank Doug Dixon of EPRI for his leadership of this project during its formative stage.

This publication is a corporate document that should be cited in the literature in the following manner:

Survival and Behavior of Juvenile Atlantic Salmon and Adult American Shad on Exposure to a Hydrokinetic Turbine.

EPRI, Palo Alto, CA: 2012.
1026904.



Abstract

This report describes a series of experiments designed to measure the effect of exposure to a full-scale, vertical axis hydrokinetic turbine on downstream migrating juvenile Atlantic salmon (N=173) and upstream migrating adult American shad (N=208). Controlled studies were performed in a large-scale, open-channel flume, and all individuals approached the turbine under volitional control. No injuries were observed, and there was no measurable increase in mortality associated with turbine passage. Exposure to the turbine elicited behavioral responses from both species, however, with salmon passing primarily over the downrunning blades. Shad movement was impeded in the presence of the device, as indicated by fewer attempts of shorter duration and reduced distance of ascent up the flume. More work should be performed in both laboratory and field conditions to determine the extent to which these effects are likely to influence fish in riverine environments.

Keywords

Behavioral effects

Fish

Hydrokinetic turbine

Laboratory flume

Table of Contents

Section 1: Introduction	1-1
Section 2: Methods	2-1
The Flume and Turbine.....	2-1
Instrumentation.....	2-8
Study Animals.....	2-10
Atlantic salmon smolts	2-10
Adult American shad.....	2-12
Analysis	2-13
Post-trial condition and survival.....	2-13
Movement behaviors.....	2-13
Section 3: Results	3-1
Instrumentation.....	3-1
Movement behaviors and survival	3-2
Section 4: Discussion	4-1
Section 5: Literature Cited	5-1

List of Figures

Figure 2-1 Test flume facility at the Conte Lab in plan view (upper panel) and elevation view (lower panel).	2-1
Figure 2-2 Detail of test area with locations of turbine, cameras, hydrophones, and PIT antennas.	2-2
Figure 2-3 Encurrent Model ENC-005-F4, vertical axis hydrokinetic turbine (elevation view).	2-3
Figure 2-4 Downstream staging and recovery area.	2-5
Figure 2-5 a-c. Test flume with turbine in (panels a and b) and out (panel c).	2-7
Figure 2-6 Flow velocity contours looking downstream, taken 2.45 m upstream and 2.45 m downstream of the turbine hub.	2-8
Figure 2-7 Tag attachment methods for smolts (upper image) and adult shad (lower image)	2-11
Figure 3-1 Distribution of passage locations for Atlantic salmon smolts passing downstream through turbine (viewed in downstream direction, gray dashed line represents swept area).	3-2
Figure 3-2 Survivorship curves for Atlantic salmon smolts and American shad exposed to turbine (solid red) and control (dashed blue) conditions.	3-3
Figure 3-3 Groundspeed of Atlantic salmon smolts as they passed downstream through the flume under treatment (red) and control conditions (blue).	3-5
Figure 3-4 Maximum distance of ascent as measured by PIT antenna number (see Figure 2-2).	3-6



List of Tables

Table 2-1 Trial test conditions and sample sizes for Atlantic salmon smolts and American shad exposed to treatment (turbine in) and control (turbine out) conditions.	2-4
--	-----



Section 1: Introduction

Hydroelectric power development has historically been problematic for migration, passage, and restoration of diadromous and other riverine migratory fishes. Dams are typically required to maintain the hydraulic head necessary to efficiently drive turbines, and these dams pose barriers to movement in both up- and downstream directions. Downstream migrants are confronted with additional risks, incurring injuries and mortality as they pass through turbines and other routes; even delays associated with passage in either direction can reduce fitness. Fishways and bypass structures can provide safe passage routes, but the structures are costly, and their performance is often poor. Because of these and related factors, hydropower development associated with dams is often blamed for declining populations of migratory and other riverine fish species.

Recently, there has been renewed interest in so-called hydrokinetic turbines. These devices are deployed in rivers or tidal zones where the kinetic energy of flowing water drives the turbines without requiring construction of dams or other obstacles. In the absence of dams, fish might pass these structures simply by swimming around them, thereby avoiding what is widely perceived as the primary environmental impact of hydroelectric generation.

Questions remain, however, as to whether such devices are indeed safe for fish passage, or indeed for aquatic communities. Even without a dam, the potential still exists for fish and other aquatic organisms to be injured by moving turbine blades. Mechanical injury is not the only concern, however, and avoidance behaviors hold their own risks. For example fish may refuse to pass the structure, in which case access to habitat may still be blocked. Sometimes fish will pass a structure, but at a reduced rate (Castro-Santos and Haro 2003). Such a structure still constitutes an impediment, and the resulting migratory delay can have substantial consequences. For example, populations of fish concentrate above or below impediments, where they may become attractive to predators, suffer energy depletion, disease risk, etc. (McLaughlin *et al.* 2012). Also delays can alter run timing and prevent fish from accessing essential habitat during key time windows (McCormick *et al.* 1998, McCormick *et al.* 2009). Because of the potential importance of behavioral effects, studies of interactions between hydrokinetic devices and fish should not be limited to immediate mechanical injury: avoidance and delay behaviors should also be quantified, and their consequences assessed (Castro-Santos *et al.* 2009, Castro-Santos and Haro 2009). Here, we summarize a series of experiments that were designed to characterize mechanical injury, avoidance behaviors, and migratory delay of migratory fish passing a hydrokinetic device in a large-scale, semi-controlled laboratory setting.

Section 2: Methods

The Flume and Turbine

The experiments described in this study were performed in the flume facility at the S.O. Conte Anadromous Fish Research Center (Conte Lab), located on the Connecticut River in Turners Falls, MA (Figures 2-1 and 2-2). This is a flow-through facility, capable of passing up to $10 \text{ m}^3\text{s}^{-1}$ of river water through the flumes. The flow was diverted from an adjacent power canal and returned to the river downstream of the associated hydropower dam.

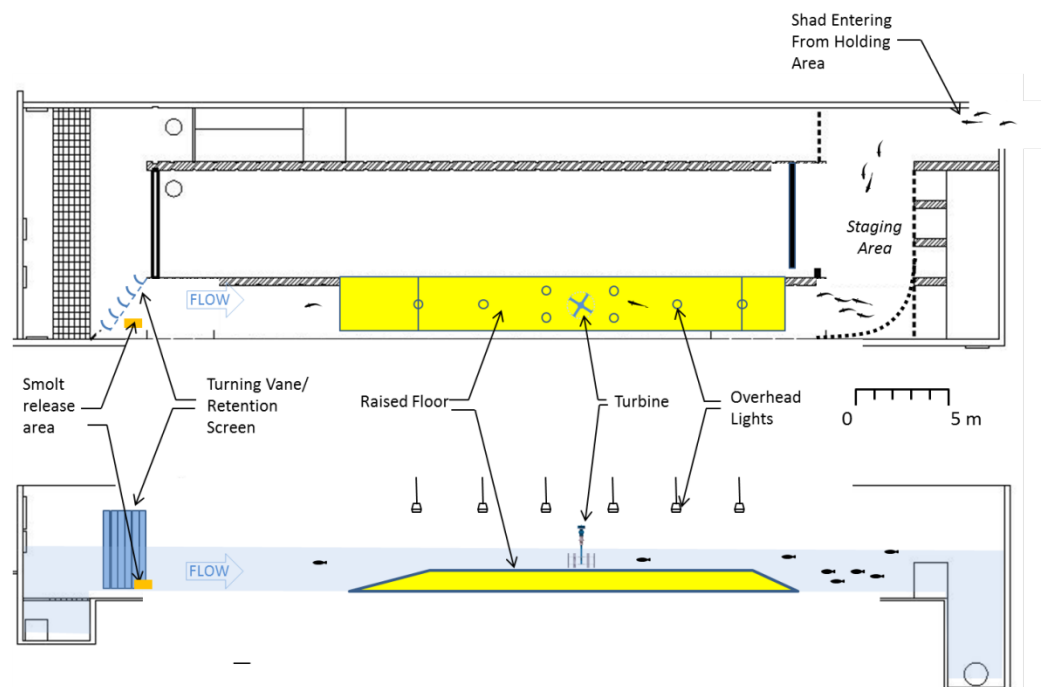

Figure 2-1

Test flume facility at the Conte Lab in plan view (upper panel) and elevation view (lower panel). Note placement of the turbine, as well as release and staging locations: shad staging area was also the recovery area for smolts. Lower panel shows elevation view of raised floor and inlet and outlet structures.

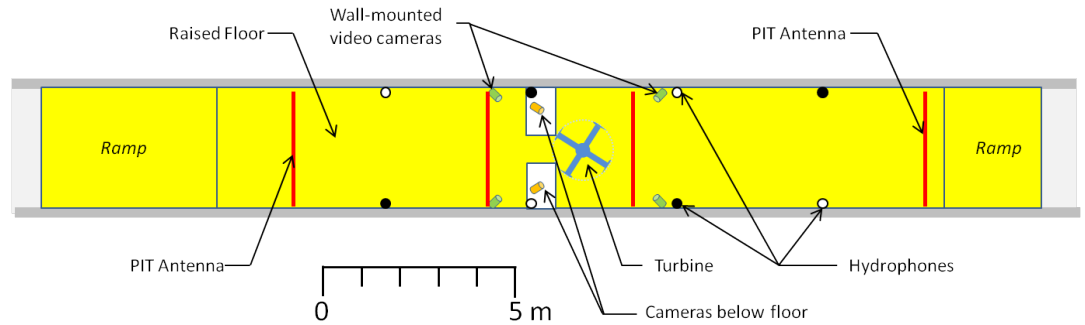

Figure 2-2

Detail of test area with locations of turbine, cameras, hydrophones, and PIT antennas. Water flow is left to right. Hydrophones were placed on walls at alternating heights of 30 cm (open circles) and 80 cm (closed circles) above the floor—this creates the optimal conditions for 2-dimensional positioning. For smolt tests, no hydrophones were placed at the downstream location; instead the uppermost hydrophones were moved to the downstream location for shad tests.

We tested live, actively migrating Atlantic salmon (*Salmo salar*) smolts and adult American shad (*Alosa sapidissima*) passing through one of these flumes outfitted with a functional hydrokinetic turbine (Encurrent model ENC-005-F4, New Energy Corp, Inc., Calgary, AB, Canada; Figure 2-3). This is a vertical axis-type turbine capable of producing 5 kW of power in flow velocities of 3 m s^{-1} . The turbine measures 1.52 m diameter with rotor height of 0.76 m. Given that the flumes at the Conte Lab measure 3.05 m wide and that flow depths of 1.21 m were required to efficiently drive the turbine, actual flow velocities averaged only about 2.25 m s^{-1} , producing a power equivalent of approximately 3 kW (Table 2-1) at a total discharge of $8.2 \text{ m}^3\text{s}^{-1}$. This is a realistic condition for many locations where these units are designed to be deployed, however, and so was deemed acceptable for biological testing.

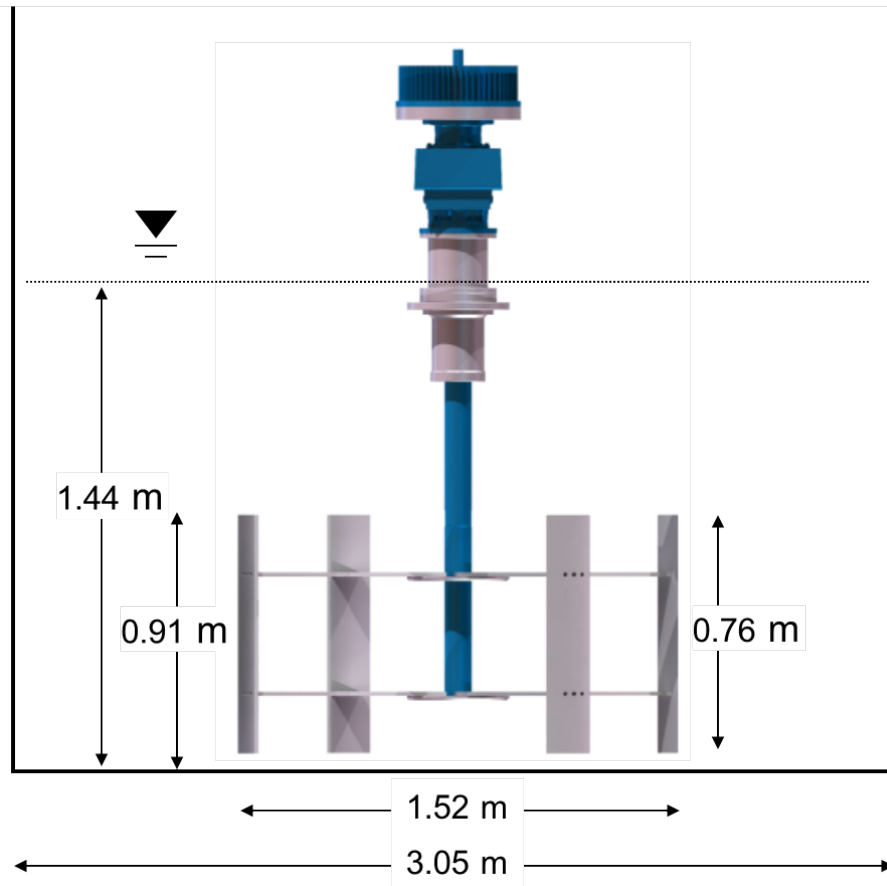

Figure 2-3
 Encurrent Model ENC-005-F4, vertical axis hydrokinetic turbine (elevation view).
 Heavy lines indicate floor and walls of the test flume. The turbine blades were 76
 cm tall by 152 cm diameter, and the device was mounted 15 cm above the floor.
 Water level shown is upstream of the turbine while running (Table 2-1); the water
 level at the same location was 1.21 m with the turbine out.

Table 2-1

Trial test conditions and sample sizes for Atlantic salmon smolts and American shad exposed to treatment (turbine in) and control (turbine out) conditions. Dates and temperatures are presented as ranges, and velocity and depth are presented as mean and standard deviations. Flow velocity is taken 2.45 m upstream of the turbine and corresponds to the 'Upstream' panels of Figure 2-6. Flow depth measurements were taken 2.45 m upstream and 2.45 m downstream of the turbine hub. Discharge was held nearly constant for both species: $8.30 \text{ m}^3\text{s}^{-1}$ (turbine in), and $8.78 \text{ m}^3\text{s}^{-1}$ (turbine out)

Species	Turbine	N	Date Range	Temp °C	Upstream Flow Velocity (m s ⁻¹)	Flow Depth (m)	
						Upstream	Downstream
Salmon smolts	In	117	May 13 - May 19	11.1 - 14.5	1.89 ± 0.13	1.44 ± 0.01	1.29 ± 0.02
	Out	56	May 13 - May 18	10.8 - 14.4	2.38 ± 0.07	1.21 ± 0.02	1.27 ± 0.02
Adult shad	In	134	May 26 - June 09	20.6 - 24.5	1.89 ± 0.02	1.44 ± 0.02	1.29 ± 0.02
	Out	74	May 26 - June 09	20.0 - 23.9	2.38 ± 0.17	1.21 ± 0.01	1.27 ± 0.01

Because we were interested in volitional behavior, it was necessary to create velocity zones both upstream and downstream of the turbine test area that were low enough to allow fish to voluntarily approach and pass it. This was accomplished by raising the floor of the flume by 60 cm for a distance of 10 m upstream and downstream of the turbine. The greater depth upstream and downstream of this raised floor caused velocities to be reduced in those sections by approximately 40% (Figure 2-1; Table 2-1). A larger area was also provided downstream to serve as a recovery area for Atlantic salmon smolts and as a resting and staging area for the upstream migrant American shad. This area consisted of a large screened corral measuring 6.1 m wide by 6.1m long adjacent to the test flume (Figures 2-1, 2-2 and 2-4). Flow was discharged through a set of screens and gates 10.3 m wide by 2.1 m tall. The screen immediately downstream of the turbine testing flume was built on a curve with a 3 m radius; this created a sweeping cross-flow that kept fish from being impinged there after passing the turbine. Screens were constructed of galvanized steel, with 1.0 cm clear opening to allow for maximum flow while minimizing risk of escapement or impingement.



*Figure 2-4
Downstream staging and recovery area. Discharge is toward the left; test flume is out of sight in background, behind the concrete wall to the right. The screen continues to arc toward the back wall as shown in Figure 2-1. Note the slack water condition, which provided suitable resting conditions for both Atlantic salmon and American shad.*

The flume was illuminated with 6-400 W mercury vapor lamps placed 2.5 m above the water surface. These were configured in such a way as to provide uniform lighting around the turbine and to avoid strong shadows from the turbine and associated mounting hardware. The intent was to at once avoid startling the fish while providing sufficient illumination for the video monitoring system (see below).

Experiments were performed using a treatment (turbine in) and control (turbine out) design. For the treatment condition, the turbine was mounted with the lower portion of its blades 15 cm above the floor and the upper portion 126 cm below the water surface (Figures 2-3 and 2-5a & b). Note that the total swept area of the turbine was 1.15 m², or 24.3% of the flume cross-section (4.76 m²). Under the control condition, discharge was held approximately constant, but the turbine was removed (Figure 2-5c; Table 2-1). This meant that staging and recovery area conditions were similar under both conditions, with the treatment comprising the turbine itself and its immediate effects on flume hydraulics. Telemetry and monitoring systems remained in place under both treatment and control conditions, allowing for direct comparison of movement patterns with the turbine present and absent.

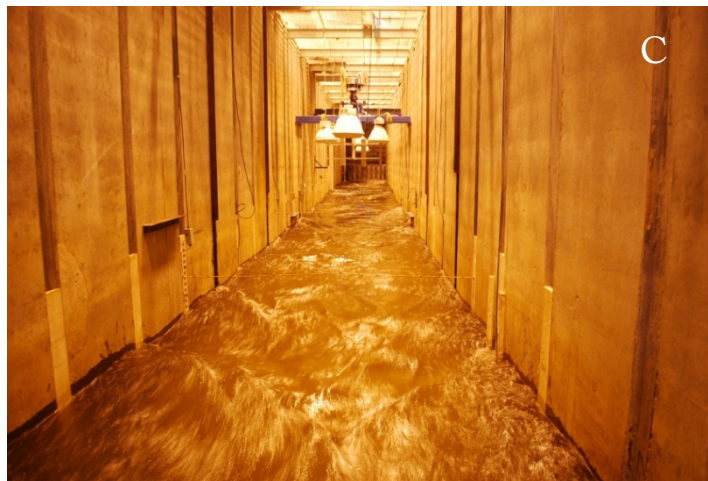

Figure 2-5
a-c. Test flume with turbine in (panels a and b) and out (panel c). Visible in panel a are the turbine, lights, PIT antennas, cameras, and hydrophones (see schematic, Figure 2-1 and 2-2). Note that the turbine created some head differential, which affected flow velocities in those zones (Table 2-1, Figure 2-6.)

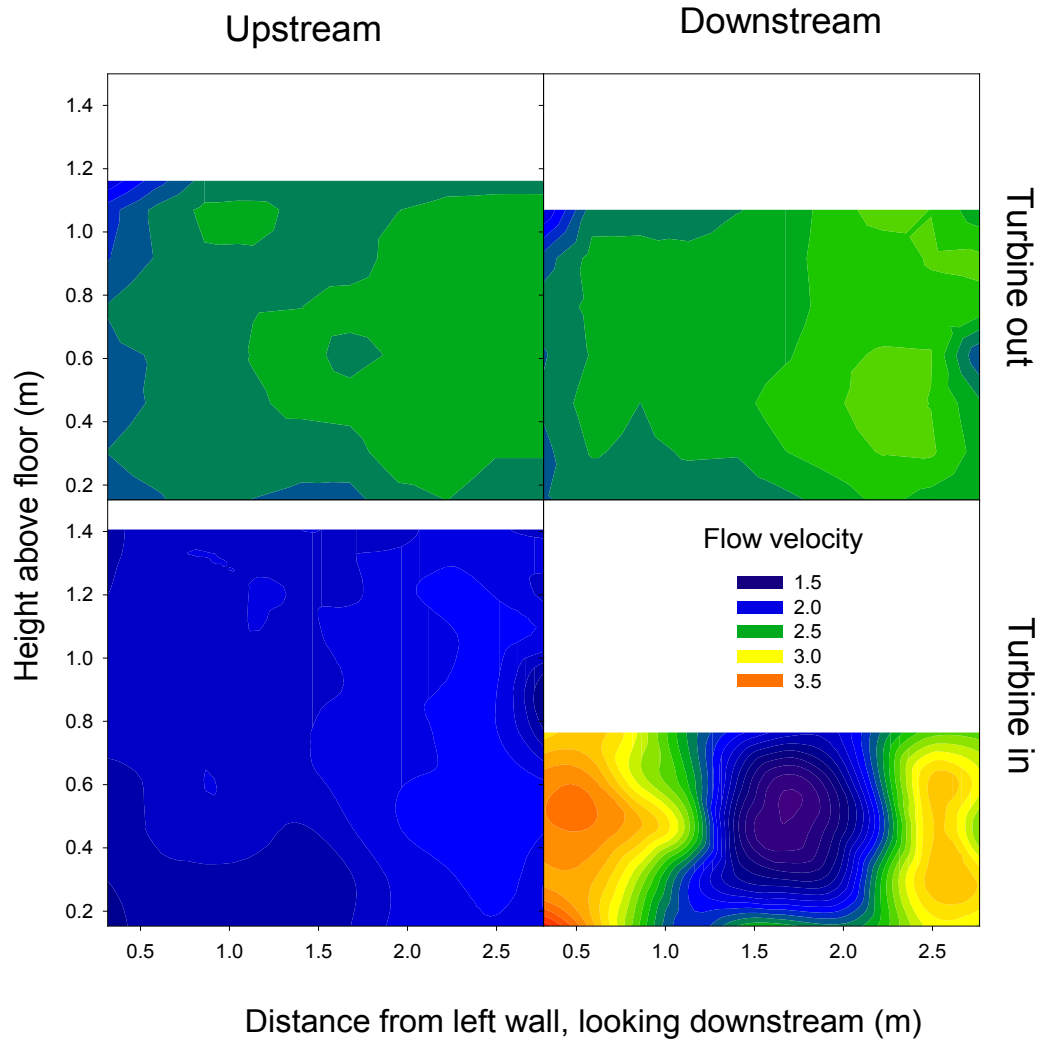

Figure 2-6
 Flow velocity contours looking downstream, taken 2.45 m upstream and 2.45 m downstream of the turbine hub. Upper panels show conditions with turbine removed, and lower panels show conditions with turbine running. Note the low velocity zones upstream and immediately downstream of the turbine, and the high velocity zones near the walls. This represents the wake shed by the turbine while running.

Instrumentation

Because of the novel nature of this study, we used several methods to monitor passage of fish past the turbine (test conditions) or the unimpeded flume (control condition), knowing that it was likely that not all monitoring methods would be effective. Passive integrated transponder (PIT) telemetry was used to monitor gross movements up or down the flume, video cameras monitored passage by the turbine itself, and an integrated hydrophone array and acoustic tracking system

(Model HTI-290; Hydroacoustic Technology Inc., Seattle, WA; hereafter termed the HTI system) monitored movements in 2-dimensional (horizontal) space with a mean time resolution of 220 ms.

A single PIT antenna was used to monitor downstream movements of Atlantic salmon smolts; this was primarily to reference passage times to allow for identification of smolts as they passed the video cameras (see below). For upstream migrants (shad) a total of 4 antennas were used, allowing for quantification of distance of ascent and delays as shad approached the turbine location.

Video cameras were deployed below the false floor, angled upward through clear acrylic panels to provide a ventral perspective of fish as they passed the turbine. The field of view was often obscured by bubbles trapped below the acrylic, however, and cameras were later moved above the floor to provide a lateral perspective of the fish.

The HTI system integrated input from an array of hydrophones that recorded the difference in arrival times of acoustic transmissions from each tag as they passed through the array. This information was used to triangulate a 2-dimensional position for the tag at each transmission time. Eight hydrophones were deployed and interfaced with the HTI system (Figure 2-2). These were positioned upstream and downstream of the turbine to provide optimum 2-dimensional coverage of fish as they approached and passed the test area. Hydrophones were placed at alternating heights of 30 and 80 cm above the false floor. For smolt tests, 4 hydrophones were placed upstream of the turbine, two in-line with the turbine, and 2 downstream of the turbine. This provided optimal coverage of the upstream end as smolts approached the turbine and were situated to maximize our ability to detect behavioral responses to the turbine before passing it. For shad, the two most upstream hydrophones were moved to the downstream location, in this case providing better coverage of the shad as they approached the turbine from the downstream direction.

Flow velocities were also monitored continuously throughout each run using acoustic Doppler current profilers (ADCP's: Sontek Argonaut, model SL3000; Sontek/YSI, San Diego, CA, USA) deployed 2.45 m upstream and 2.45 m downstream of the turbine location. Velocities were measured in 10 discrete cells, each measuring 0.28 m long. Cells were distributed laterally and uniformly across the flume channel and velocities were recorded every 60 seconds. Representative velocity conditions were also recorded at several locations along the flume, creating full, 2-dimensional profiles of flow velocity to which test animals were subjected.

For each of these systems, PIT, Video, HTI, and ADCP, clocks on the associated instruments were synchronized to the nearest second at the beginning of each trial. This allowed for later comparisons and verification among the various types of data.

Study Animals

Because hydrokinetic devices such as the Encurrent Model ENC-005-F4 are meant to be deployed in locations with anadromous migrant fishes, we wanted to explore effects on both the upstream migrant (adult) and downstream migrant (juvenile or smolt) phases. Some of the proposed siting locations, like the Yukon and Mackenzie Rivers have important populations of migratory salmonids, so our first choice was to select a salmonid species. Because our laboratory discharges directly to the Connecticut River, however, we are unable to test non-native fish that might escape and colonize the river or transmit disease. Atlantic salmon are available in this system, but because this is a population under restoration only hatchery-reared juveniles were available for testing. For this reason we used Atlantic salmon smolts as our representative species for the juvenile life stage. The Connecticut River also has a large native population of anadromous American shad. Adults of this species are large, averaging around 435 mm in length, or about the adult size of many large salmonids. Shad are also susceptible to handling, which makes them a good indicator species—any injury that would harm an adult salmonid would almost certainly have a greater effect on American shad. Furthermore, shad are known as a ‘nervous’ fish, one that is easily deterred from passing obstacles or conditions that might be perceived as unnatural. This is also a useful characteristic because it means that behavioral effects of the turbine would likely be easier to observe in shad than in some other species. Thus shad were chosen as a surrogate species for adult salmonids and other anadromous fish, providing conservative estimates of both injury and behavioral effects of the turbine.

Atlantic salmon smolts

209 Atlantic salmon smolts were obtained from the Dwight D. Eisenhower National Fish Hatchery in Pittsborough, VT and transported by truck to the Conte Lab. Upon arrival, smolts were immediately transferred to 2 m diameter round tanks, where they were held and fed to satiation twice daily. Two days after arrival, feeding was withheld, and all smolts were anaesthetized and tagged with 23 mm passive integrated transponders (PIT tags; Castro-Santos *et al.* 1996). At this time smolts were divided equally into two new 2 m diameter tanks and allowed to recover. Two days after tagging, smolts from one of these tanks were transferred to a 23 m long open-channel swim chamber (Haro *et al.* 2004, Castro-Santos 2005). This chamber, originally designed for studying sprinting performance, was outfitted with a low-velocity staging area downstream. Flows were regulated such that the flume maintained a depth of 50 cm and a mean flow velocity of 0.5 m s⁻¹. These conditions were provided to give the smolts opportunity to exercise and swim in an open-channel environment, and so hopefully be better able to swim at speeds representative of wild fish when exposed to the turbine test arena. Throughout this holding period smolts were fed twice daily and monitored for mortality. Only healthy individuals were used for testing.

On the day of a test, smolts were transferred to the upstream end of the flume facility, and once test flows were established, the fish were tagged with acoustic telemetry tags, which had been outfitted with steel loops and suture threads for this purpose (Figure 2-7). Tags were set to transmit at a very rapid rate (4-5 transmissions per second). This transmission rate limited tag life, and in order to maximize sample size tags were activated and attached just before beginning each test. This timing also meant that anesthesia could not be used when tagging smolts as it would likely have affected their ability to respond to the turbine. Instead, smolts were restrained without anesthesia and tagged by passing the suture thread through the skin just behind the dorsal fin and tying it off to the loop. This technique prevented the suture thread from cinching down on the skin and possibly ripping it—in this way we simultaneously avoided injuring the fish and reduced the risk of losing the tags. Also at this time each fish was inspected visually for any signs of injury. This information was recorded and used for comparison with post-run condition assessments (see below). Total handling time was typically < 30 s.

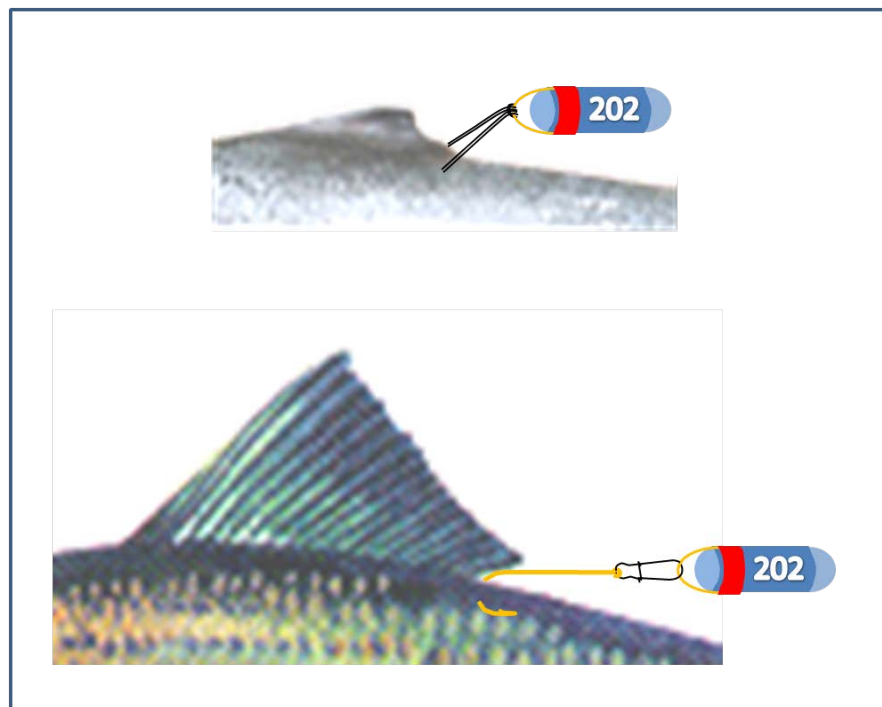

Figure 2-7
Tag attachment methods for smolts (upper image) and adult shad (lower image)

After tagging, smolts were transferred to a recovery tank where they were held for 1-5 minutes before being released into the test flume. Once they had recovered (as evidenced by upright swimming and active response to researchers) smolts were transferred to the test flume by bucket and released in a slack-water zone about 20 m upstream of the turbine (Figure 2-1). Structures were placed in this zone on the floor and walls to create flow refugia in which smolts were able to hide before volitionally entering the flume. In this way we hoped to have

smolts approach the turbine under their own control, and in a way that was as close to the natural environment as could be achieved in our laboratory.

Once a trial was complete, and all smolts had been released and passed the turbine or control condition, flow through the flume was reduced and smolts were collected with dip nets and transferred by bucket to 1 m diameter holding tanks for recovery. There they were fed *ad libitum* and monitored several times daily for a minimum of 48 h. Time of death was recorded to the nearest h. Survivors were either euthanized or, when possible, released into the Connecticut River to supplement ongoing restoration efforts there. Before euthanasia or release, all smolts were visually inspected and any signs of injury were recorded.

Adult American shad

Adult, actively migrating American shad were collected from a fishlift at Holyoke Massachusetts and transferred by truck to holding facilities at the Conte Lab. The truck was outfitted with a 4.2 m³ round tank specifically designed for transporting shad, with a recirculating pump and supplementary oxygen provided at a rate of 10 L minute⁻¹. Water for transport was treated with a simulated seawater solution diluted to 7.5 ppt. This solution is standard for shad transportation and helps reduce stress and disease associated with transport.

Upon arrival at the Conte Lab shad were PIT-tagged (IP) and deposited in groups of 20 into large flow-through holding tanks adjacent to, and hydraulically connected with the flume facility (Burrows and Chenoweth 1970). The following day, a subset of each collection was fitted with acoustic transmitters. The attachment differed from that used for smolts. In this case, the acoustic tags were fitted with #6 Aberdeen style gold-plated fishhooks coated with epoxy. This method allows for rapid tagging and detagging so that tags could be used repeatedly in successive experiments (Castro-Santos *et al.* 1996). Once this subset was tagged, all shad from a given holding pond were seined and transferred into the staging area downstream of the test flume. A screen situated at the downstream end of the flume kept shad from entering while flow levels were raised to the test condition. Once test conditions were established, the screen was raised and shad were allowed to enter and ascend the flume volitionally. Throughout each trial, shad had free access to the flume and the staging area. Often shad would ascend the flume, fall back downstream, and then hold in the staging area. In other cases shad remained in the upstream end for the duration of the trial. At the end of each trial, flows were reduced and shad were returned to the staging area and seined back into the holding ponds, where they were monitored several times a day for mortalities. For each mortality, PIT ID and time were recorded and the animal was assessed for injuries. Survivors were likewise inspected before release.

Analysis

Post-trial condition and survival

Survival rates for both salmon and shad were compared using Kaplan–Meier survivorship curves and statistical comparisons using Wilcoxon and LogRank tests (Kaplan and Meier 1958, Allison 1995, Hosmer *et al.* 2008). These are well-established, nonparametric methods for comparing survival rates for treatment and control animals and are superior to logistic and other forms of binomial comparison of two groups because they explicitly include a time component and allow for testing of differences in mortality over time. These methods are also robust against unequal time intervals for monitoring such as happens, for example, when lab personnel were absent overnight. Thus the multiple observations per day act to improve resolution of the tests and are unaffected by the comparatively longer gaps that typically occurred at night. This technique also allowed us to include data from animals that were held for greater than 48 hours. Furthermore, the two tests applied have different sensitivities, with the Wilcoxon test being more sensitive to differences in survival early in the time series (left side of the distribution) and LogRank tests being more sensitive to the later part of the time series (right side of the distribution).

Movement behaviors

Video was recorded continuously throughout each trial by 4 cameras interfaced with a multiple input digital video recorder (Tyco Model TVR-08025; Tyco Video, Boca Raton, FL). Passage events were identified using PIT records (recorded separately), and video was reviewed for several seconds before and after each recorded event. If a fish was identified, its position was documented, along with any observations of strike, avoidance behavior, passage route, etc.

PIT data were compiled in a database containing ID, location, and time to the nearest 0.01 s. For salmon smolts, passage times were recorded along with any observations of fish returning upstream. The data for shad were more complex. Here it was possible to identify individual ascent attempts, and in many cases more than one attempt was made. Likewise, not all shad staged attempts. For each condition, proportion attempting was recorded and compared using logistic regression between treatment and control conditions. Distributions of number of attempts staged were compared using a Kolmogorov-Smirnov test. Because each antenna had a known location, it was also possible to use the PIT array to estimate maximum distance of ascent (Haro *et al.* 2004).

HTI Data were summarized as location information on a horizontal plane, with position resolved to the nearest second.



Section 3: Results

A total of 173 salmon smolts and 208 adult American shad were introduced to the flume structure (Table 2-1). For both species, more individuals were subjected to the treatment condition (turbine in) than the control (turbine out). This allowed us to improve our estimates of survivorship for those individuals that were exposed to the turbine, while still including enough data from control fish for performing statistical comparisons between treatment and control groups.

In the case of the salmon smolts, flow velocities exceed the swimming ability of the fish and so all individuals ultimately passed downstream. Typically, smolts passed the turbine within about 30 s of release time, although a few individuals were able to hold position upstream for as long as 90 s.

Flume conditions varied by trial condition (Table 2-1 and Figure 2-6). With the turbine in place and running, water was held back, creating a head drop across the turbine. A zone of high-velocity flow occurred along the walls downstream of the turbine, and a zone of low-velocity flow occurred immediately downstream of the turbine. Flow downstream of the turbine was also visibly quite turbulent. Flow velocities in the upstream and downstream staging areas were not measured. As mentioned above, hydraulic conditions in the upstream staging area were sufficiently energetic that all smolts moved downstream shortly after release. The downstream area was much more tranquil, however, and smolts and shad could be easily observed during the trials resting and holding station without any indication of stress or fatigue. Moreover, no fish of either species were impinged on the discharge screens under either treatment or control conditions, providing further evidence that the downstream staging area provided suitable resting habitat.

Instrumentation

Performance of instrumentation varied between the two species. For the salmon smolts, only a single PIT antenna was in place—this was intended primarily for identifying passage times to facilitate video viewing. Turbid conditions and bubbles obstructed much of the video; however we were able to characterize spatial distribution of 33 smolts (Figure 3-1) and 14 shad passing the turbine zone. Fortunately, the HTI system provided excellent data for many of the salmon smolts (N=85). Only a subset of all the introduced shad carried acoustic tags, and because entry was volitional, data were obtained from a smaller sample (N=23).

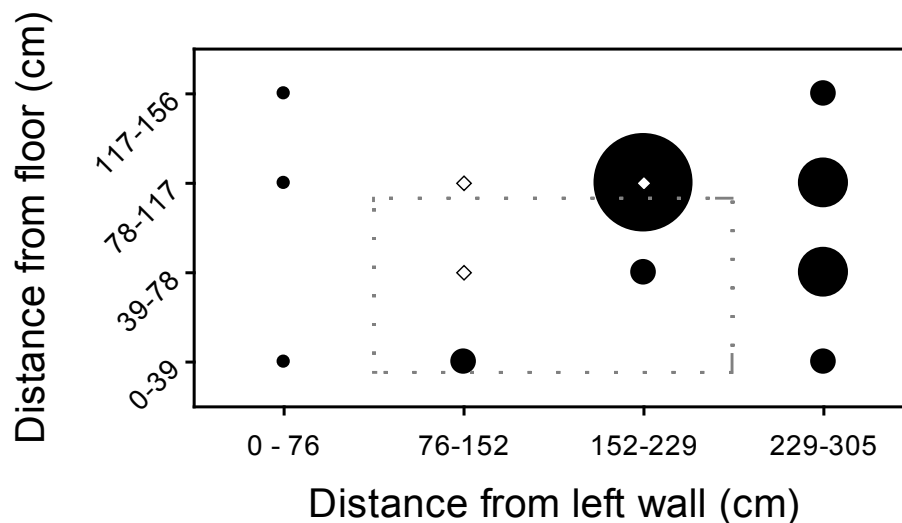

Figure 3-1
 Distribution of passage locations for Atlantic salmon smolts passing downstream through turbine (viewed in downstream direction, gray dashed line represents swept area). Bubble size scales with number, with largest bubble indicating 8 individuals and smallest indicating single observations. White diamonds represent observations with the turbine removed, black circles represent observations with the turbine in place. The turbine spun in a counter-clockwise direction, viewed from above, i.e. the right side of the panel was associated with the downstream sweep of the turbine blades.

Movement behaviors and survival

With the turbine running, 43 (72%) smolts passed through, above, or beneath the swept area of the blades, and 17 (28%) passed around the outside of the blades. This is significantly greater than a 50:50 ratio (binomial distribution, $p < 0.0001$), despite the fact that the swept area of the blades only occupied 50% of the flume width. This raises the possibility that smolts were actively entrained or attracted to the turbine. However an alternate explanation exists, which is that the smolts were simply avoiding the walls, or perhaps being drawn to the center of the flume by the greater velocities present there (Figure 2-6). This can be assessed by comparing treatment and control conditions, and under the control condition we also observed a tendency of smolts to gravitate toward the center of the flume, with 15 (60%) individuals passing in the turbine zone (with the turbine removed), and only 10 (40%) passing outside of that zone. This difference was not significantly different from 50% ($P = 0.167$). Taken together, however, the turbine did not significantly affect the likelihood of passing through the swept area (logistic regression, $p = 0.486$). Thus it is likely that the tendency to pass down the center of the flume reflects either volitional or passive avoidance of the walls and preference for the center of the flume.

Despite the high incidence of turbine passage, we observed no injuries to individual smolts following trials. Also overall survival was high, with 48 hour survival of 98.3% for treatment smolts and 96.4% for controls (Figure 3-2). This difference was non-significant (LogRank $p = 0.41$; Wilcoxon $p = 0.29$). It is important to recognize, however, that this study was designed to identify strong effects. Given the observed mortality among controls, the power provided by these sample sizes to detect 5% or 10% increases in mortality at a 0.05 significance level was 0.225 and 0.517, respectively, meaning that negative results should be interpreted with caution.

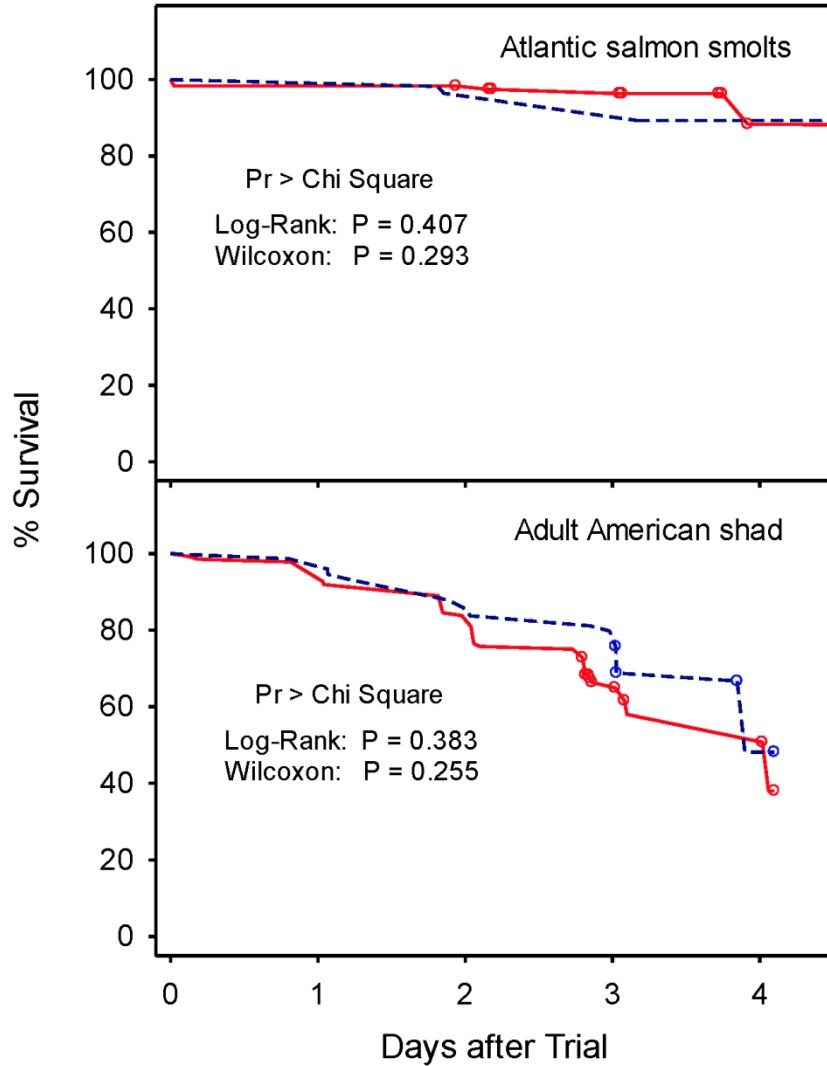

Figure 3-2
 Survivorship curves for Atlantic salmon smolts and American shad exposed to turbine (solid red) and control (dashed blue) conditions. Circles indicate censoring, when survivors were either sacrificed or returned to the river to continue their migration.

The unbalanced design yielded some benefit, however, in that it improved the precision of the total mortality estimate for smolts exposed to the turbine. From the binomial distribution, the 98.3% survival estimate has a 95% confidence interval from 95.4-99.7%.

The low mortality rate may be attributable in part to the route through which most smolts passed the turbine. Video analysis suggests that smolts were disproportionately inclined to pass over the top and around the side of the downstream-sweeping side of the turbine blade when the turbine was present (Figure 3-1; Chi Square $p=0.05$). Body orientation of smolts to the current was variable, and about equally distributed among upstream-oriented, downstream-oriented, or sideways as they passed the cameras. Also, the observed spatial distribution is reminiscent of the velocity field (Figures 2-6 and 3-1)—it is possible therefore that the fish distribution is affected by flow, but given the distribution it is likely that volitional response to the turbine had some effect on passage route.

Assessment of the speed at which smolts moved relative to the flow suggests that there was some ability to orient to and resist the current (Figure 3-3). There was noticeable hesitation in the Upstream zone for both treatment and control fish. This probably represents a response to the elevated floor and associated flow acceleration. In the presence of the turbine smolts were slightly slower in the approach zone than when it was removed, and slightly faster downstream as they exited the flume. These differences were non-significant, but are evocative of slight hesitation upstream of the turbine by some individuals, and perhaps escape behavior following passage. Several tracks appeared to indicate disorientation immediately following passage, which accounts for the slight drop in groundspeed in the Departure zone (Figure 3-3). It is important to recognize that, given the variability in behavior, it is possible that the observed patterns may have arisen by chance.

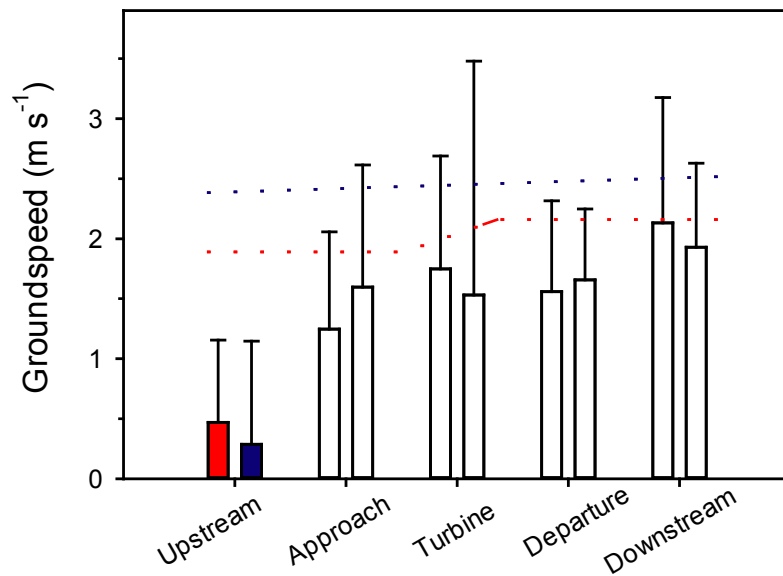

Figure 3-3

Groundspeed of Atlantic salmon smolts as they passed downstream through the flume under treatment (red) and control conditions (blue). This figure partitions the flume into 'Upstream' (> 4 m upstream of the turbine hub), 'Approach' (1-4 m upstream of the turbine hub), 'Turbine' (1 m upstream to 1 m downstream of the hub), 'Departure' (1 -4 m downstream of the turbine hub) and 'Downstream' (> 4m downstream of the turbine hub). Columns are means and error bars are standard deviations of groundspeed. This entire range is above the horizontal portion of the elevated floor, and so the reduced groundspeed upstream suggests either some response to the floor or pre-fatigue efforts to hold station in the rapid flow. The dashed lines show mean velocity of the bulk flow under each condition. Differences between groundspeeds for treatment and control conditions were nonsignificant for all zones, owing at least in part to strong variability in groundspeed. Mean groundspeeds were consistently less than flow velocity, however, indicating that smolts were resisting the current, backing downstream as they passed the turbine zone.

Behavior of American shad was very different from salmon smolts. Both PIT and HTI systems provided detailed information on movements, with consistent results. By quantifying lags between detections it was possible to discriminate among attempts (Castro-Santos and Perry 2012). Shad staged more attempts when the turbine was removed (mean \pm SD number of attempts= 1.13 ± 2.1 with turbine in, and 1.80 ± 2.8 with turbine out (Wilcoxon, $p = 0.125$)), and spent more time in the flume with the turbine out (median = 43.0 s) than in (median = 21.0 s; Wilcoxon $p < 0.001$). Although the difference in attempt number might have arisen by chance, several shad staged large numbers of attempts with the turbine out. This created strong inequality of variance ($p > F = 0.002$). Taken together, these results indicate that shad were more willing to enter the flume,

and to expend greater effort attempting to pass the high velocity zone in the absence of the turbine than with it present.

For those shad that did enter the flume, there was a clear effect of the turbine on distance of ascent, with more shad passing the turbine location with the turbine removed than when it was in and running (Figure 3-4; Wilcoxon $p=0.004$; LogRank $p=0.734$). Shad were more likely to arrive at Antenna 4 once they passed the turbine. This may reflect avoidance of the turbine or improved swimming ability in the relatively lower flow velocities present upstream of the turbine when it was running. With the turbine running, shad moved through the turbine zone more slowly than with it absent ($p<0.001$). Much of this time was spent holding station near, or in several cases within the swept area of the blades. With the turbine running shad were more likely to occupy the zone near the downrunning blades ($p = 0.02$), although there was broad overlap in distribution between the two conditions.

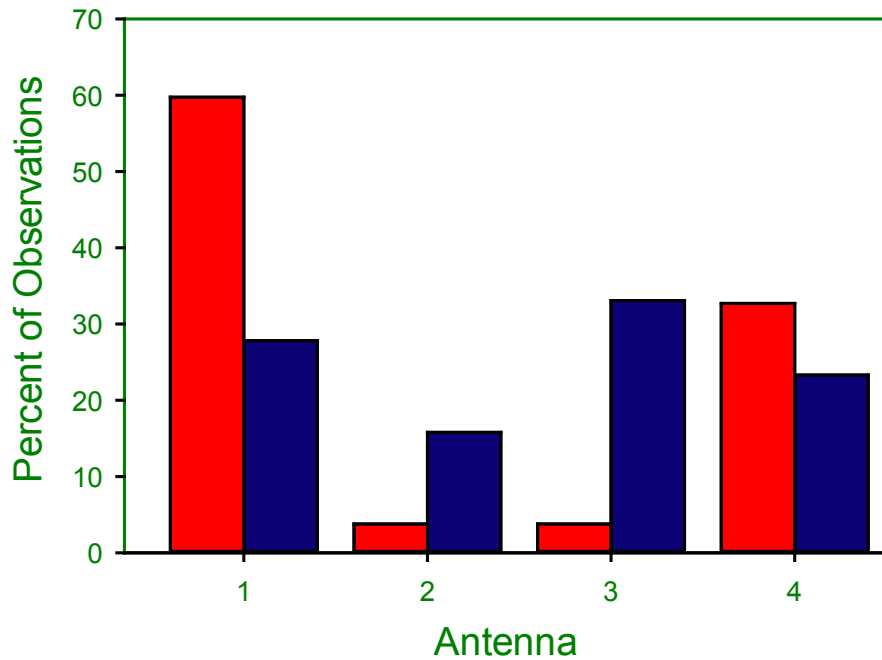

Figure 3-4
Maximum distance of ascent as measured by PIT antenna number (see Figure 2-2). Antennas are numbered moving from downstream to upstream, i.e. flow moves from right to left, and turbine is located between Antennas 2 and 3. Red bars are treatment conditions, and blue bars are control conditions.

As with the salmon data, post-test assessment of shad condition yielded no evidence of strike injuries, and survival of treatment and control groups was comparable (Figure 3-2; Wilcoxon $p = 0.126$; LogRank $p = 0.413$). Both groups of shad suffered greater mortality than did the salmon, especially after 2 days of post-trial observation (note that shad are sensitive to confinement, and these animals had been held for a total of >3 days). The observed mortality rates were consistent with those observed among shad held in these same facilities without any handling after being transported (Sullivan 2004). Interestingly, post-test mortality was actually greater among shad that staged few or no attempts (Cox's proportional hazard regression, $p < 0.001$). This suggests: a) that entry into the flume and exposure to the turbine had no detrimental effect, and b) that the observed mortality reflected variability in condition of the fish, rather than the effect of being subjected to the turbine treatment. Given the observed mortality among controls, the power to detect a 10% increase in mortality after 48 h was 0.59 with this sample size, but after 96 h decreased to 0.29. Therefore, despite the apparent lack of treatment effect, negative results must be viewed with caution.



Section 4: Discussion

The most striking result of this study is the apparent lack of any injury or mortality incurred as a result of passing through the turbine for either species. Even conservative estimates of turbine-induced mortality indicate values <5%. This is comparable with expected survival through the most fish-friendly turbine designs currently in use, such as some Kaplan turbines, and is also comparable to experimental units under development with the specific objective of reducing harm to fish (Bell and Kynard 1985, Stier and Kynard 1986, Odeh 1999, EPRI 2011a).

In order to definitively show lower mortality rates, studies with much larger sample sizes would have to be conducted. The power of tests on turbine mortality studies is important because it informs us of the scale of likely effects. For example, a sensitivity of 5% may be sufficient if only a small number of turbines deployed on a large river system with a strong diversity of spawning habitat (and hence several discrete stocks of philopatric species like the salmonids). As a unit in a larger array, however, of, say, thousands of similar devices, this level of certainty could rapidly become unacceptable. On such a scale of deployment, sample size for survival studies like this one would have to increase dramatically. This is particularly true for species like American shad, which are sensitive to handling and holding. As mortality rate of controls increases, the relative sample size needed to detect effects also increases (Skalski 1998, Skalski *et al.* 2001, Perry *et al.* 2012). This need for large sample sizes and controlled follow-up is one great advantage of laboratory studies over field studies—handling effects and losses to follow-up can be minimized, meaning that laboratory studies can be far more efficient at detecting survival effects than field studies.

A counterpoint to the above is that the smolts used in this study were of hatchery origin, and the flume environment is highly artificial. The turbine occupied a much larger proportion of the flume than would be expected in a field situation. Also, actual behaviors of wild smolts in a free-flowing river may differ from what was tested here. Because of this, any conclusions drawn from this and other laboratory work should be viewed as preliminary and subject to verification in the field.

Similar conclusions can be applied to the adult American shad. In this case the fish were wild, and their behaviors may be more representative of what one would expect in the field. Here again, though, the flume environment is highly artificial and movements were constrained. The observed reluctance to pass the turbine may be less of an issue if it were to be deployed in a larger river system, with

more space above, below, and around the turbine through which fish could pass unimpeded.

Field studies have their own problems, however. To date, we know of only one survival study performed on an in-river hydrokinetic turbine (NAI 2009). This study likewise found no significant incidence of injury or turbine-associated mortality. The power of their tests were slightly lower than ours ($\pm 5\%$ at a $p=0.1$ level of significance). Their studies were limited to survival, however, with no information on behavioral effects. Also, the Normandeau Associates study (NAI 2009) used balloon tags to recover fish. This method is useful, because it eliminates the need to use passive netting to recover test and control fish. The method itself can affect behavior, however, and studies performed at conventional hydroelectric facilities have shown that they can underestimate longer term mortality associated with turbine passage (Ferguson *et al.* 2006). Nevertheless, this type of study can provide preliminary information, and the results of the Normandeau Associates (2009) study are largely consistent with what we observed.

Our handling techniques also likely affected survival, particularly among Atlantic salmon smolts. Because the Conte Lab is a flow-through facility, water quality can be variable, and during these trials video quality was poor. At least one other large laboratory exists that has resolved this problem by using a large-scale closed-circuit flume. Comparable studies performed at this facility using video analysis yielded similar results to ours, with even fewer fish being struck by blades than would be predicted by chance alone (EPRI 2011b). Moreover, because they had excellent water clarity, these researchers were able to definitively document avoidance behaviors of fish. Here again, the results were similar to what we observed, with fish holding station near the spinning turbine blades, but actively avoiding strike, and incurring minimal injury even when strike occurred.

None of the foregoing studies quantified behavioral effects, however. Behavioral barriers are a concern because they create a situation in which fish may avoid passage, or reduce the rate of passage (i.e. increase the time required to pass). On the scale of an individual unit, such delays may be inconsequential, but at larger scales, with many turbines deployed throughout a river system, cumulative effects could lead to reduced spawning viability, reduced access to habitat, and possibly increased risk of predation, disease transmission, etc. (Bickford and Skalski 2000, Castro-Santos and Letcher 2010, Harris and Hightower 2012). American shad are notorious for being reluctant to pass structures of many designs, and these results should be viewed as a preliminary indication of possible affects on upstream adult migrant fishes. As with the salmon smolt data, any conclusions drawn from laboratory studies should be viewed as preliminary and subject to verification in field settings. Furthermore, likely effects of deployed turbines in the field will vary as a function of the number of units deployed and the scale and hydrography of the deployment location.

A final note of caution: these studies were performed on only two species, and were done under strong lighting conditions. Other species and life stages might have responded differently to this turbine, and more data on a greater diversity of

species would help define the scale of likely effects. Also, many riverine and migratory species are most active at night. Although we saw evidence that fish passing through this turbine appeared not to suffer injury, it is an open question as to whether the same would be true under low-light conditions. Further work is needed to address this question. Lessons learned from this study have shown the difficulty of using video to monitor movements of fish in naturally turbid waters, but also the benefits of advanced telemetry systems to offset this challenge. Alternative video and acoustic technology should be applied to see if they produce better imagery; infrared video might hold some promise as well. Regardless, additional study on other species, life stages, lighting, and hydraulic conditions would further advance the conclusions and broader relevance of this study.



Section 5: Literature Cited

Allison, P. D. 1995. *Survival analysis using the SAS system: a practical guide*. SAS Institute, Inc., Cary, NC.

Bell, C. E. and B. Kynard. 1985. Mortality of adult American shad passing through a 17-megawatt Kaplan turbine at a low-head hydroelectric dam. *North American Journal of Fisheries Management* **5**: 33-38.

Bickford, S. A. and J. R. Skalski. 2000. Reanalysis and interpretation of 25 years of Snake-Columbia River juvenile salmonid survival studies. *North American Journal of Fisheries Management* **20**: 53-68.

Burrows, T. E. and H. H. Chenoweth. 1970. The rectangular circulating rearing pond. *The Progressive Fish Culturist* **32**: 67-80.

Castro-Santos, T., A. J. Haro and S. Walk. 1996. A passive integrated transponder (PIT) tagging system for monitoring fishways. *Fisheries Research* **28**: 253-261.

Castro-Santos, T. and A. J. Haro. 2003. Quantifying migratory delay: a new application of survival analysis methods. *Canadian Journal of Fisheries and Aquatic Sciences* **60**: 986-996.

Castro-Santos, T. 2005. Optimal swim speeds for traversing velocity barriers: an analysis of volitional high-speed swimming behavior of migratory fishes. *The Journal of Experimental Biology* **208**(3): 421-432.

Castro-Santos, T., A. Cotel and P. W. Webb. 2009. Fishway evaluations for better bioengineering -- an integrative approach. In: A. J. Haro, K. L. Smith, R. A. Rulifson, C. M. Moffitt, R. J. Klauda, M. J. Dadswell, R. A. Cunjak, J. E. Cooper, K. L. Beal and T. S. Avery (eds.). *Challenges for Diadromous Fishes in a Dynamic Global Environment*. American Fisheries Society, Bethesda, Maryland. pp 557-575.

Castro-Santos, T. and A. J. Haro. 2009. Fish guidance and passage at barriers. In: P. Domenici and R. W. Blake (eds.). *Fish Locomotion: An Etho-Ecological Approach*. Science Publishers, Inc., Enfield, NH.

Castro-Santos, T. and B. H. Letcher. 2010. Modeling migratory bioenergetics of Connecticut River American shad (*Alosa sapidissima*): implications for the conservation of an iteroparous anadromous fish. *Canadian Journal of Fisheries and Aquatic Sciences* **67**: 806-830.

EPRI (Electric Power Research Institute). 2011a. *EPRI-DOE Conference on Environmentally-Enhanced Hydropower Turbines: Technical Papers*. Palo Alto, CA. 1024609. December 2011.

EPRI (Electric Power Research Institute). 2011b. *Evaluation of Fish Injury and Mortality Associated with Hydrokinetic Turbines*. Palo Alto, CA. 1024569. November 2011.

Ferguson, J. W., R. F. Absolon, T. J. Carlson and B. P. Sandford. 2006. Evidence of delayed mortality on juvenile Pacific salmon passing through turbines at Columbia River Dams. *Transactions of the American Fisheries Society* **135**(1): 139-150.

Haro, A., T. Castro-Santos, J. Noreika and M. Odeh. 2004. Swimming performance of upstream migrant fishes in open-channel flow: a new approach to predicting passage through velocity barriers. *Canadian Journal of Fisheries and Aquatic Sciences* **61**(9): 1590-1601.

Harris, J. E. and J. E. Hightower. 2012. Demographic population model for American shad: Will access to additional habitat upstream of dams increase population sizes? *Marine and Coastal Fisheries* **4**: 262-283.

Hosmer, D. W., S. Lemeshow and S. May. 2008. *Applied survival analysis : regression modeling of time-to-event data*. Wiley-Interscience, Hoboken, N.J.

Kaplan, E. L. and P. Meier. 1958. Nonparametric estimation from incomplete observations. *Journal of the American Statistical Association* **53**: 457-481.

McCormick, S. D., L. P. Hansen, T. P. Quinn and R. L. Saunders. 1998. Movement, migration, and smolting of Atlantic salmon (*Salmo salar*). *Canadian Journal of Fisheries and Aquatic Sciences* **55**: 77-92.

McCormick, S. D., D. T. Lerner, M. Y. Monette, K. Nieves-Puigdoller, J. T. Kelly and B. T. Bjornsson. 2009. Taking it with you when you go: How perturbations to the freshwater environment, including temperature, dams, and contaminants affect marine survival of salmon. In: A. J. Haro, K. L. Smith, R. A. Rulifson, C. M. Moffitt, R. Klauda, M. J. Dadswell, R. A. Cunjak, J. E. Cooper, K. L. Beal and T. S. Avery (eds.). *Challenges for Diadromous Fishes in a Dynamic Global Environment*. pp 195-214.

McLaughlin, R. L., E. R. B. Smyth, T. Castro-Santos, M. L. Jones, M. A. Koops, T. C. Pratt and L.-A. Vélez-Espino. 2012. Unintended consequences and trade-offs of fish passage. *Fish and Fisheries*: DOI: 10.1111/faf.12003.

NAI (Normandeau Associates, Inc.). 2009. *An Estimation of Survival and Injury of Fish Passes Through the Hydro Green Energy Hydrokinetic System, and a Characterization of Fish Entrainment Potential at the Mississippi Lock and Dam No. 2 Hydroelectric Project (P-4306), Hastings Minnesota*. Prepared for Hydro Green Energy, LLC by Normandeau Associates, Inc. December 2009.

Odeh, M. 1999. *A Summary of Environmentally Friendly Turbine Design Concepts*. Prepared for United States Department of Energy, Idaho Operations Office, Advanced Hydropower Turbine System Program. DOE/ID/13741. July 1999.

Perry, R. W., T. Castro-Santos, C. M. Holbrook and B. P. Sandford. 2012. Using Mark-Recapture Models to Estimate Survival from Telemetry Data. In: N. S. Adams, J. W. Beeman and J. Eiler (eds.). *Telemetry Techniques: A User Guide for Fisheries Research*. American Fisheries Society, Bethesda, Maryland. pp 453-476.

Skalski, J. R. 1998. Estimating season-wide survival rates of outmigrating salmon smolts in the Snake River, Washington. *Canadian Journal of Fisheries and Aquatic Sciences* **55**: 761-769.

Skalski, J. R., J. Lady, R. Townsend, A. E. Giorgi, J. R. Stevenson, C. M. Peven and R. D. McDonald. 2001. Estimating in-river survival of migrating salmonid smolts using radiotelemetry. *Canadian Journal of Fisheries and Aquatic Sciences* **58**: 1987-1997.

Stier, D. J. and B. Kynard. 1986. Use of radio telemetry to determine the mortality of Atlantic salmon smolts passed through a 17-MW Kaplan turbine at a low-head hydroelectric dam. *Transactions of the American Fisheries Society* **115**: 771-775.

Sullivan, T. J. 2004. *Evaluation of the Turners Falls fishway complex and potential improvements for passing adult American shad*. M.S. Thesis. University of Massachusetts Amherst.

Export Control Restrictions

Access to and use of EPRI Intellectual Property is granted with the specific understanding and requirement that responsibility for ensuring full compliance with all applicable U.S. and foreign export laws and regulations is being undertaken by you and your company. This includes an obligation to ensure that any individual receiving access hereunder who is not a U.S. citizen or permanent U.S. resident is permitted access under applicable U.S. and foreign export laws and regulations. In the event you are uncertain whether you or your company may lawfully obtain access to this EPRI Intellectual Property, you acknowledge that it is your obligation to consult with your company's legal counsel to determine whether this access is lawful. Although EPRI may make available on a case-by-case basis an informal assessment of the applicable U.S. export classification for specific EPRI Intellectual Property, you and your company acknowledge that this assessment is solely for informational purposes and not for reliance purposes. You and your company acknowledge that it is still the obligation of you and your company to make your own assessment of the applicable U.S. export classification and ensure compliance accordingly. You and your company understand and acknowledge your obligations to make a prompt report to EPRI and the appropriate authorities regarding any access to or use of EPRI Intellectual Property hereunder that may be in violation of applicable U.S. or foreign export laws or regulations.

The Electric Power Research Institute Inc., (EPRI, www.epri.com) conducts research and development relating to the generation, delivery and use of electricity for the benefit of the public. An independent, nonprofit organization, EPRI brings together its scientists and engineers as well as experts from academia and industry to help address challenges in electricity, including reliability, efficiency, health, safety and the environment. EPRI also provides technology, policy and economic analyses to drive long-range research and development planning, and supports research in emerging technologies. EPRI's members represent approximately 90 percent of the electricity generated and delivered in the United States, and international participation extends to more than 30 countries. EPRI's principal offices and laboratories are located in Palo Alto, Calif.; Charlotte, N.C.; Knoxville, Tenn.; and Lenox, Mass.

Together...Shaping the Future of Electricity

Program:

Waterpower

© 2012 Electric Power Research Institute (EPRI), Inc. All rights reserved. Electric Power Research Institute, EPRI, and TOGETHER...SHAPING THE FUTURE OF ELECTRICITY are registered service marks of the Electric Power Research Institute, Inc.

1026904

Electric Power Research Institute

3420 Hillview Avenue, Palo Alto, California 94304-1338 • PO Box 10412, Palo Alto, California 94303-0813 USA
800.313.3774 • 650.855.2121 • askepri@epri.com • www.epri.com