



European
Commission

JRC SCIENCE FOR POLICY REPORT

Supply chain of renewable energy technologies in Europe

*An analysis for wind,
geothermal and ocean
energy*

Magagna, Davide
Shortall, Ruth
Telsnig, Thomas
Uihlein, Andreas
Vázquez Hernández, Cristina

2017



This publication is a Science for Policy report by the Joint Research Centre (JRC), the European Commission's science and knowledge service. It aims to provide evidence-based scientific support to the European policymaking process. The scientific output expressed does not imply a policy position of the European Commission. Neither the European Commission nor any person acting on behalf of the Commission is responsible for the use that might be made of this publication.

Contact information

Name: Andreas Uihlein
Address: European Commission, Joint Research Centre, P.O. Box 2, 1755 ZG Petten, The Netherlands
Email: andreas.uihlein@ec.europa.eu
Tel.: +31 224 56 5123

JRC Science Hub

<https://ec.europa.eu/jrc>

JRC108106

EUR 28831 EN

PDF ISBN 978-92-79-74281-1 ISSN 1831-9424 doi:10.2760/271949

Luxembourg: Publications Office of the European Union, 2017

© European Union, 2017

Reuse is authorised provided the source is acknowledged. The reuse policy of European Commission documents is regulated by Decision 2011/833/EU (OJ L 330, 14.12.2011, p. 39).

For any use or reproduction of photos or other material that is not under the EU copyright, permission must be sought directly from the copyright holders.

How to cite this report: Magagna, D., Shortall, R., Telsnig, T., Uihlein, A. and Vazquez Hernandez, C., *Supply chain of renewable energy technologies in Europe - An analysis for wind, geothermal and ocean energy*, EUR 28831 EN, Publications Office of the European Union, Luxembourg, 2017, ISBN 978-92-79-74281-1, doi:10.2760/271949, JRC108106.

All images © European Union 2017, except: cover page, gkrphoto, 67954208, 2015. Source: Fotolia.com

Title: Supply chain of renewable energy technologies in Europe - An analysis for wind, geothermal and ocean energy

Abstract

This report aims at providing an overview of the supply chain of a number of renewable energy technologies. The report currently addresses the following technologies in detail: wind energy, geothermal energy and ocean energy but might be expanded at a later stage.

In particular, the report focuses on the current market for renewable energy technologies and components and the position of EU companies and organisations as well as the EU's strengths and weaknesses. The main EU companies and competitors from outside the EU for each part of the supply chain or market segment are also presented.

Contents

- Acknowledgements 1
- Executive summary 2
- 1 Introduction 4
- 2 Wind energy 5
 - 2.1 Global wind turbine suppliers 5
 - 2.2 Global wind energy supply chain and the positioning of the European sector 7
 - 2.3 Supply of the main wind turbine components 15
 - 2.3.1 Blades 18
 - 2.3.2 Drive train 19
 - 2.3.2.1 Power generator 20
 - 2.3.2.2 Gearbox 20
 - 2.3.2.3 Power converter 21
 - 2.3.3 Towers 21
 - 2.3.4 Other electrical components (control systems and transformers) 21
 - 2.3.5 Other parts of the supply chain with lower impact on turbine costs 22
 - 2.3.6 Offshore wind balance of plant 22
- 3 Geothermal energy 23
 - 3.1 Geothermal power 24
 - 3.1.1 Power turbines 24
 - 3.1.2 Other parts of the supply chain 25
 - 3.2 Ground source heat pumps market 28
 - 3.3 Direct use 31
- 4 Ocean energy 32
 - 4.1 Tidal energy developers 34
 - 4.2 Tidal components 34
 - 4.3 Wave energy 37
- References 39
- List of abbreviations and definitions 42
- List of figures 43
- List of tables 44

Acknowledgements

The authors would like to thank the following individuals for reviewing the document: Dr Efstathios Peteves, Dr Evangelos Tzimas and Mr Roberto Lacal Arántegui from the European Commission's Joint Research Centre (JRC). This report has benefitted from thorough review and valuable input from: Mr Philippe Dumas from the European Geothermal Energy Council, Mr Jacopo Moccia from Ocean Energy Europe and Mr Ivan Pineda and Mr Aloys Nghiem from WindEurope.

Authors

All authors contributed equally to this work. They are listed in alphabetical order:

Davide Magagna

Ruth Shortall

Thomas Telsnig

Andreas Uihlein

Cristina Vázquez Hernández

Executive summary

Europe has the ambition to become the world leader in renewable energy. To reach this goal it is necessary that Europe leads globally in terms of electricity generated by renewable sources and in the development of renewable technologies. Technological leadership requires a strong and stable industrial sector to sustain deployment targets and R&D effort. In this report we provide an overview of the supply chains of three renewable energy technologies: wind, geothermal and ocean energy.

Market share

Europe is at the forefront in the development and manufacturing of wind, geothermal and ocean energy technologies:

- The market share of the European Original Equipment Manufacturers (OEM) in the wind energy sector continues to show a positive trend over the last years. Among the Top 10 OEMs for wind turbine supply in 2016 European OEMs are leading with 41 % followed by the leading Chinese (23 %) and North American (12 %) companies.
- Ground source heat pumps (GSHP) make up the largest portion of the geothermal energy market in the EU (22.8 GW installed) with Sweden and Germany having the largest portion of installed capacity.
- The geothermal turbine market in Europe has been dominated by dry steam or flash technology but binary technology installations are on the increase. The main players in the turbine industry globally are Japanese or American companies, with 80 % of the market, although in the EU, Ansaldo-Tosi of Italy holds 30 % of the market.
- District heating systems are the fastest growing direct use application of geothermal energy in the EU, with 190 systems (1.7 GW) installed.
- The EU is global leader in the development of ocean energy technologies being home to approximately half of the world's tidal energy developers and 60% of wave energy developers.

Number of companies

Europe has a leading role in terms of number of companies active in the wind, geothermal and ocean energy sectors:

- With about 3700 companies the EU is leading the wind power sector and is actively seeking new markets outside the European borders.
- Globally, the EU region has the second highest number of geothermal organisations next to the USA, with around 225 organisations.
- More than 100 companies in EU are active in the ocean energy sector. European leadership is strengthened by the availability of 70 % of the ocean energy research and testing infrastructure.

Manufacturing capabilities/ organisational integration

Europe shows high manufacturing capabilities in the wind and ocean energy sectors and in ground source heat pumps and geothermal energy systems.

- European manufacturers show overcapacities in all key wind turbine components, when compared to the present and future European demand, at deployment rates between 12.1 and 22.7 GW/year. Expected deployment rates at global level suggest an additional market potential for European manufacturers outside the EU.
- Wind turbine components are manufactured either in-house or by independent suppliers. Leading OEMs have in-house manufacturing capacity for the most critical wind turbine components. The exception is the gearbox component which is outsourced by almost all turbine vendors.

- As the wind energy market grows in emerging markets such as Asia, the outsourcing of blades to independent suppliers is gaining popularity among the OEMs as it offers a higher flexibility of supply.
- The Asian independent suppliers lead the global outsourcing market of blades, power converters and towers while the European independent suppliers lead in control systems. As transformers are a standardized power transmission product, transformer suppliers are located across all major markets.
- European manufacturing capability is limited for conventional geothermal turbines, since the market is dominated by Japanese players, but European actors are gaining ground in binary-ORC manufacture, which can be used for lower temperature resources, thus increasing the possibilities for exploitation.
- The EU shows strong capability in ground source heat pumps and geothermal energy systems, but Asian companies are also breaking into the EU market.
- European industries are well positioned to take advantage of the emergence of the ocean energy market within the EU and globally. OEMs are re-gaining interest in the ocean energy sector, which also benefits from a large number of leading components manufactures (bearings, electrical components) that can support the growth of the sector.

Location of manufacturing activity

Manufacturing and assembly of key components in the wind, geothermal and ocean energy sectors are often local activity, either in the place of deployment or in the country of the company's headquarter:

- Most European manufacturing facilities are located in the country of the company's headquarter or countries with increased wind energy deployment. Manufacturing related with blades, nacelles and the general turbine assembly show the highest number of facilities in Europe.
- Given the spread of ocean energy resources around Europe, it can be expected that once the market is established, manufacturing and assembly facilities will be located in proximity to high-resources area.
- GSHP manufactures are located in Germany, Sweden, UK, France, Austria and Switzerland. The main players in GSHP manufacturing are Sweden and Germany, countries with the greatest use of GSHP.
- European manufacturers of binary-ORC turbines are increasing and companies are to be found in Italy, Switzerland and the UK.

1 Introduction

This report aims at providing an overview of the supply chains of a number of renewable energy technologies ⁽¹⁾. The report currently addresses the following technologies in detail: wind energy, geothermal energy and ocean energy. Nevertheless, it might be expanded at a later stage.

In particular, the report focuses on the current market for renewable energy technologies and components and the position of EU companies and organisations as well as the EU's strengths and weaknesses. The main EU companies and competitors from outside the EU for each part of the supply chain or market segment are presented.

A part of the information contained in this report stems from the European Commission's internal Low Carbon Energy Observatory project which was complemented and updated. In addition, information from the Joint Research Centre's (JRC) energy technology status reports have been used (Magagna, Monfardini, & Uihlein, 2016; Sigfússon & Uihlein, 2015; Vázquez Hernández et al., 2017).

⁽¹⁾ In this report, we define supply chain as comprising "every effort involved in producing and delivering a final product or service, from the supplier's supplier to the customer's customer" according to The Supply Chain Council. In contrast, a value chain would be a broader "set of activities that are performed to design, produce and market, deliver and support its product" (Porter, 1985). The value chain is more focused on the competitive strength of an organisation and the added value it provides to a customer.

2 Wind energy

The supply chain of the wind energy sector can be divided in three distinct phases: development and planning, installation and manufacturing and operation of the wind power plant (Figure 1).

Figure 1. Wind energy supply chain with components and subcomponents

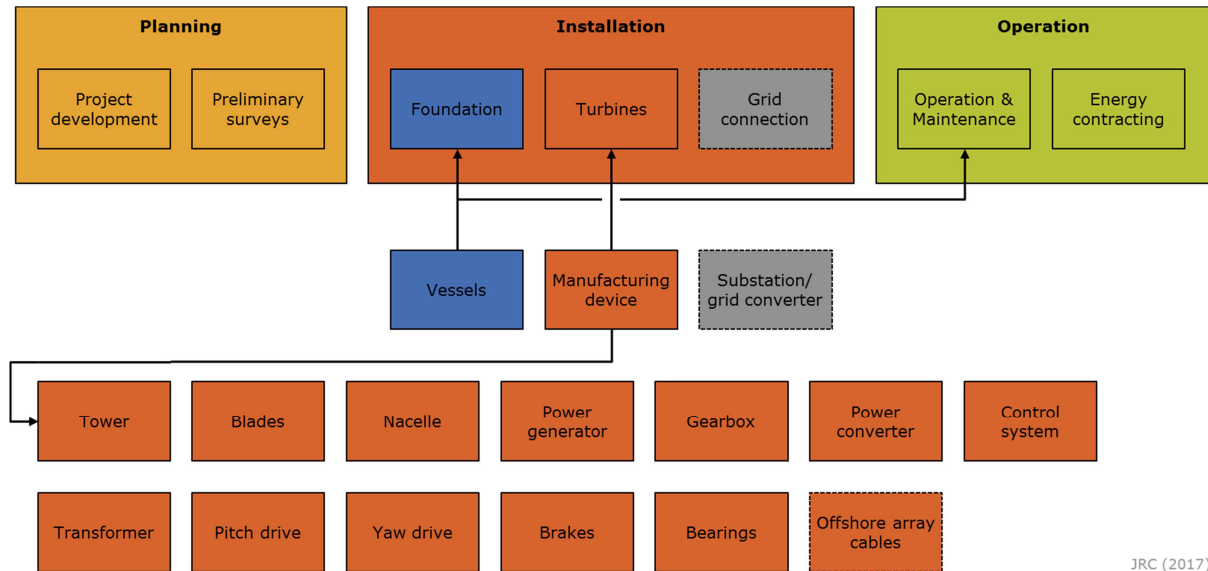

JRC (2017)

Source: JRC

Note: Dotted boxes refer to offshore wind

The supply chain analysis presented in this study focuses on the supply of the single turbine components. The major components considered are: towers, rotors blades, nacelle housing, power generators, gearboxes, power converters, control systems, transformers, pitch drives, yaw drives, brake systems and bearings.

In the following sections, firstly a broad overview of the global wind energy supply chain and the positioning of the European sector is presented. Secondly, an analysis focused on the supply of the main wind turbine components is given.

2.1 Global wind turbine suppliers

In 2016 the new installed capacity of wind energy reached 56.8 GW globally. Figure 2 displays the market share of the top 10 OEMs (Original Equipment Manufacturers) over the period 2010-2016 classified based on their location ⁽²⁾. As shown, the leading European OEMs accounted for at least 41 % of the new global installed capacity in 2016 followed by the leading Chinese and North American companies with 23 % and 12 % respectively. It is important to note that these figures are referring to the global market share of the OEM and not to the location where manufacturing takes place.

Figure 3 represents the top 10 OEMs over the period 2010-2016. 2016 was characterised by the return of Vestas to the top of global manufacturers as a consequence of their increased activity in the US market. Similarly, GE Renewable Energy (2nd place) and Enercon (5th place) increased their installations compared to 2015 as a result of their strong domestic market growth. Four Chinese turbine suppliers were among the top 10. Nevertheless, Chinese companies ranked lower compared to the previous year due to a drop in China's wind power installations.

⁽²⁾ The geographical zone considered corresponds to the location of the headquarters of the company.

Figure 2. Market share (%) of the top 10 wind turbine suppliers by geographical zone from 2010 to 2016

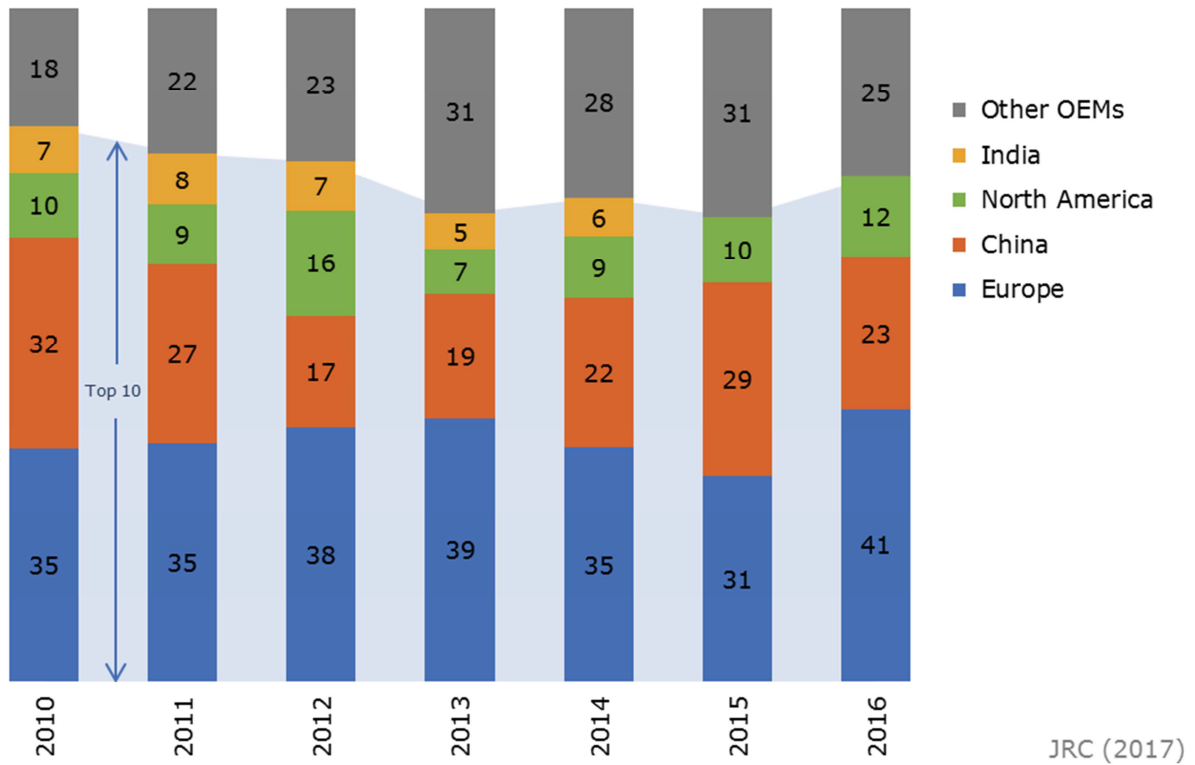

Source: JRC

Note: "Other OEMs" includes those OEMs whose market share is not high enough to be in the top 10.

Figure 3. Market share (%) of top 10 wind turbine suppliers by manufacturer from 2010 to 2016

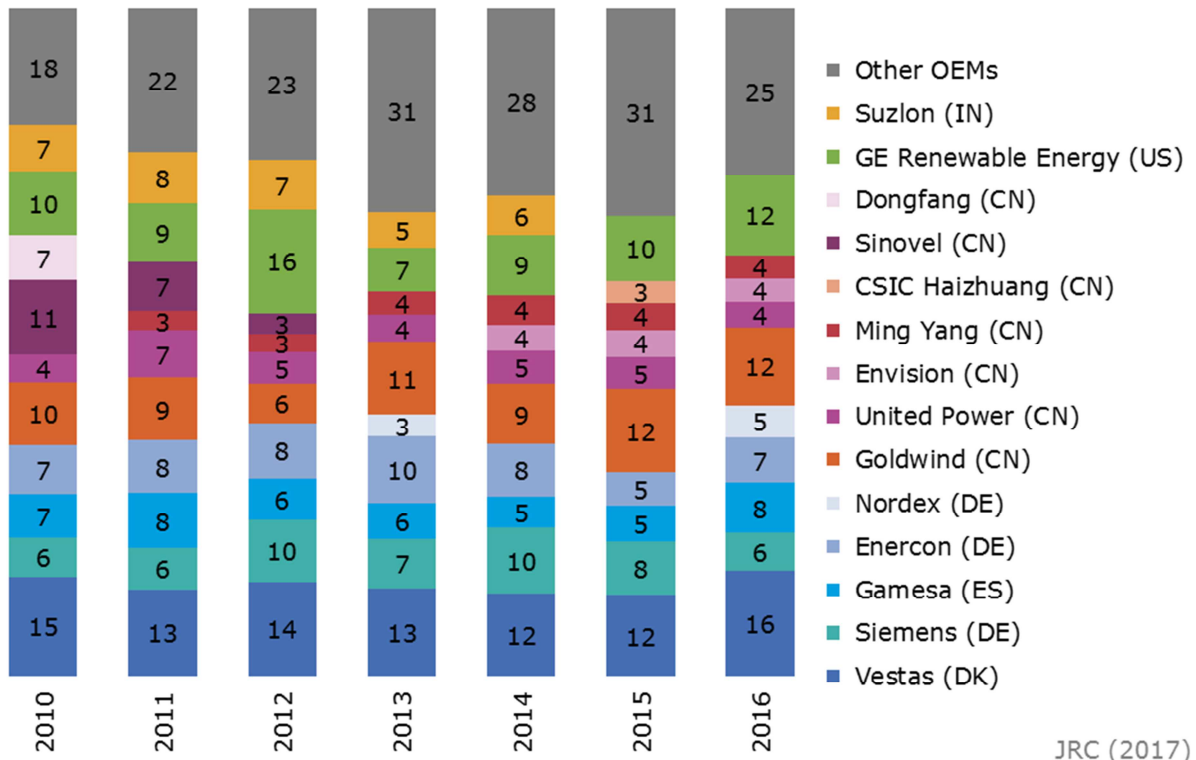

Source: JRC

Note: Since April 2017 Siemens and Gamesa were merged becoming Siemens Gamesa Wind Power.

2.2 Global wind energy supply chain and the positioning of the European sector

The positioning of the EU can be assessed by considering how European manufacturers rank, where production takes place or where component suppliers are located. As previously seen, the EU is currently home to four of the top 10 wind energy manufacturers. One of the key advantages of the presence of manufacturers in the EU is the employment generated by the production facilities. Nevertheless, additional jobs also result from R&D, management and sales activities. For example, 46 % of the Vestas employees in Europe in 2016 are involved in "sales and services".

Figure 4 displays the location and company affiliation of manufacturing facilities of the European OEMs in Europe. In addition to that, Figure 5 shows the component manufactured at the respective manufacturing facility. It can be observed that most manufacturing facilities are located in Spain, Germany and Denmark.

The highest number of manufacturing facilities in Europe are associated with blade manufacturing (28), followed by nacelle manufacturing (22) and the assembly of wind turbine components (11).

Not surprisingly, the main OEMs locate their manufacturing facilities not only where their headquarters are but also in countries where they supply wind turbine components and services. Gamesa (ES) and Senvion SE (DE) are exceptions; their manufacturing facilities are only placed in their country of origin. Similarly, smaller OEMs tend to have their facilities around their headquarters (Table 1). Examples are: Acciona (ES), Alstom Wind (FR), Lagerwey (NL), Mervento (FI), Riablades (PO), Sway (NO) and Turbowinds (BE).

Figure 4. Manufacturing facilities of European OEMs based in Europe classified according to OEM

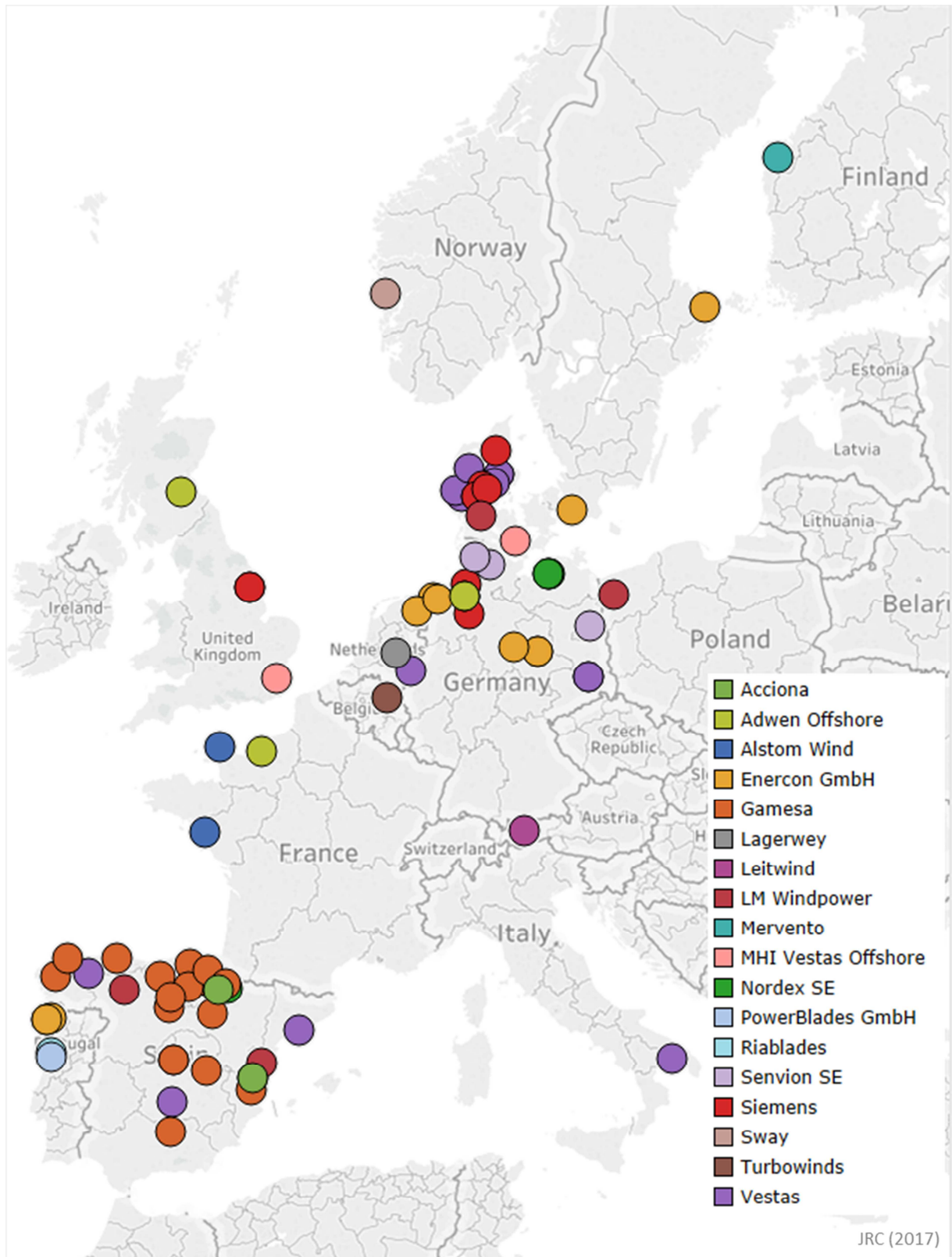

Sources: (Anonymous, 2017; Navigant Consulting, 2013) and JRC data

Figure 5. Manufacturing facilities of European OEMs based in Europe classified according to component

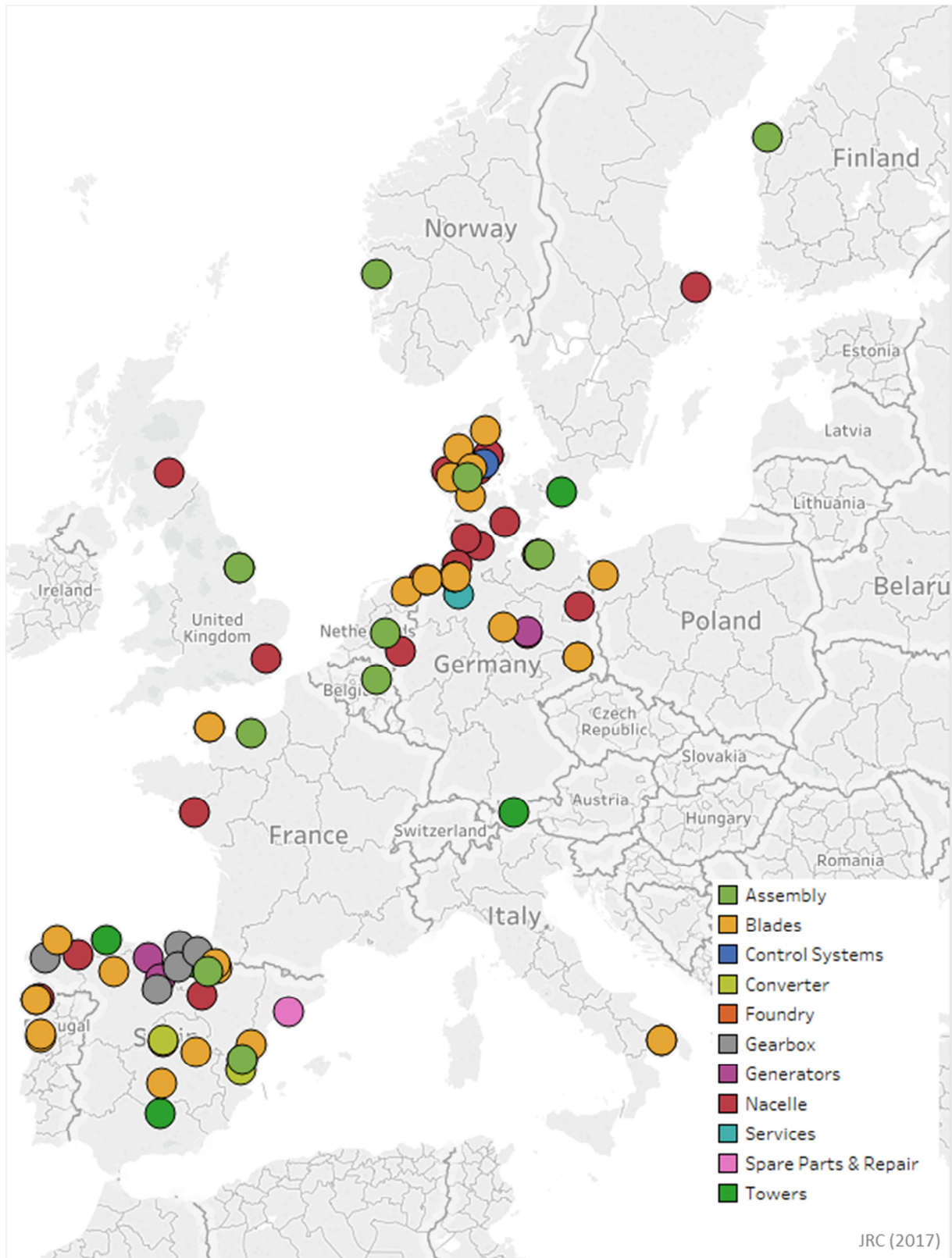

Sources: (Anonymous, 2017; Navigant Consulting, 2013) and JRC data

Table 1. Main wind manufacturing facilities of European OEMs based in Europe

European OEM	Manufacturing business	Location
Acciona (ES)	Assembly	Spain
	Blades	Spain
Adwen Offshore (DE)	Assembly	France, Germany
	Nacelle	Germany, United Kingdom
Alstom Wind (FR)	Blades	France
	Generators	France
	Nacelle	France
	Towers	France
Enercon GmbH (DE)	Blades	Germany, Portugal
	Foundry	Germany
	Generators	Germany, Portugal
	Nacelle	Germany, Portugal, Sweden
	Towers	Sweden
Gamesa (ES)	Blades	Spain
	Generators	Spain
	Gearbox	Spain
	Nacelle	Spain
	Power converter	Spain
	Towers	Spain
Lagerwey (NL)	Assembly	Netherlands
Leitwind (IT)	Towers	Austria
LM Windpower (DK)	Blades	Denmark, Poland, Spain
Mervento (FI)	Assembly	Finland
MHI Vestas Offshore Wind (DK)	Nacelles	Denmark, United Kingdom

European OEM	Manufacturing business	Location
Nordex SE (DE)	Assembly	Germany
	Blades	Spain, Germany
	Nacelle	Spain, Germany
PowerBlades GmbH (DE)	Blades	Germany, Portugal
Riablades (PO)	Blades	Portugal
Senvion SE (DE)	Blades	Germany
	Nacelle	Germany
Siemens (DE)	Assembly	Denmark, United Kingdom
	Blades	Denmark
	Nacelle	Denmark, United Kingdom, Germany
Sway (NO)	Assembly	Norway
Turbowinds (BE)	Assembly	Belgium
Vestas (DK)	Blades	Denmark, Germany, Italy, Spain
	Control Systems	Denmark
	Nacelle	Denmark, Germany, Italy, Spain
	Spare Parts & Repair	Denmark, Spain, Italy

Sources: (Anonymous, 2017; Navigant Consulting, 2013), JRC data

Since the global wind market is growing, all turbine manufacturers have started to enter new markets (Figure 6). Especially the European OEMS have increased their presence in more and more countries during the last 10 years. Chinese manufacturers are mainly focused on their home market with the exception of Goldwind which is also present outside China.

Figure 6. Number of countries served by turbine manufacturers with at least 50 MW of capacity each

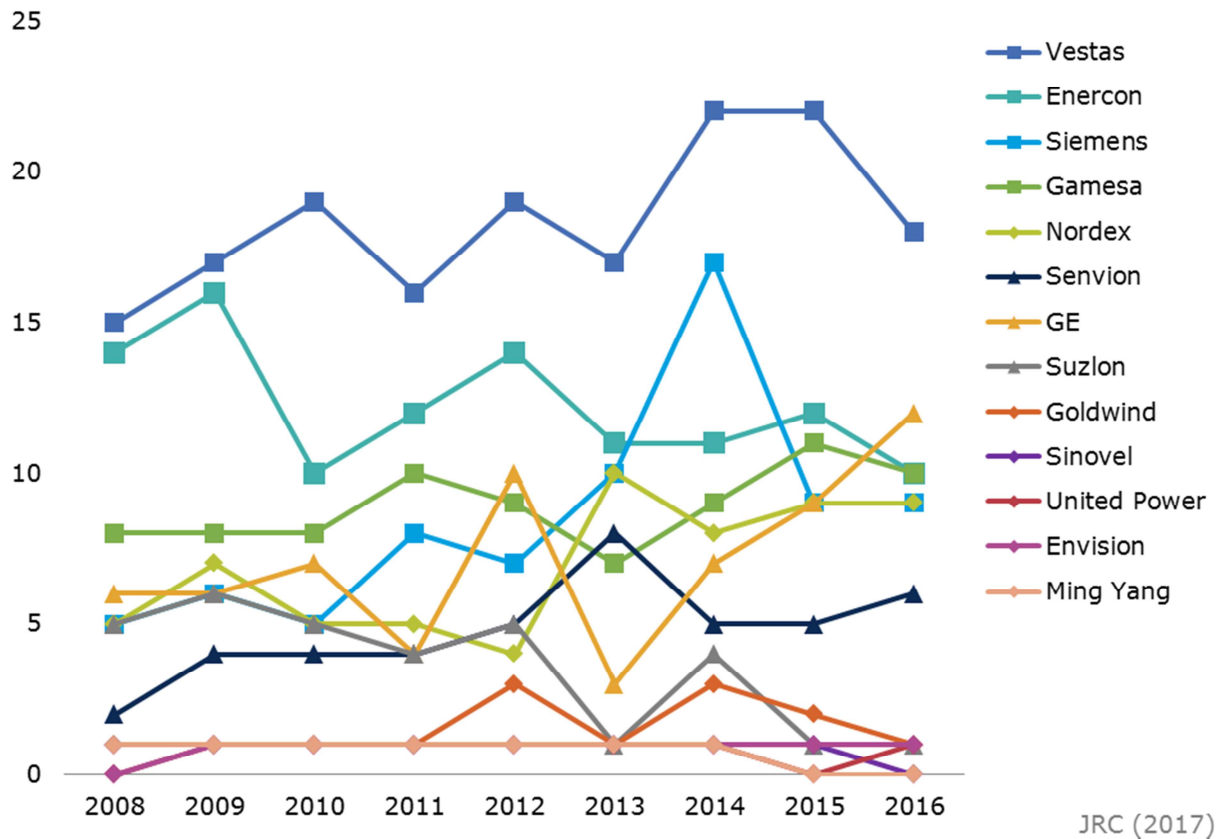

JRC (2017)

Source: JRC Data

Note: Please note that data for 2016 are not complete

A list of companies active in the wind power sector is given in Figure 7. The largest share of companies is located in the United States (about 1450), followed by China and India (about 1300 and 920, respectively). The EU as a whole clearly leads the wind power sector with about 3700 companies (almost 40 %). Other countries that are main players in the wind power sector, such as Spain, Brazil, and Denmark are also among the top 15 countries.

Figure 7. Organisations in the wind energy sector: top 15 countries and EU

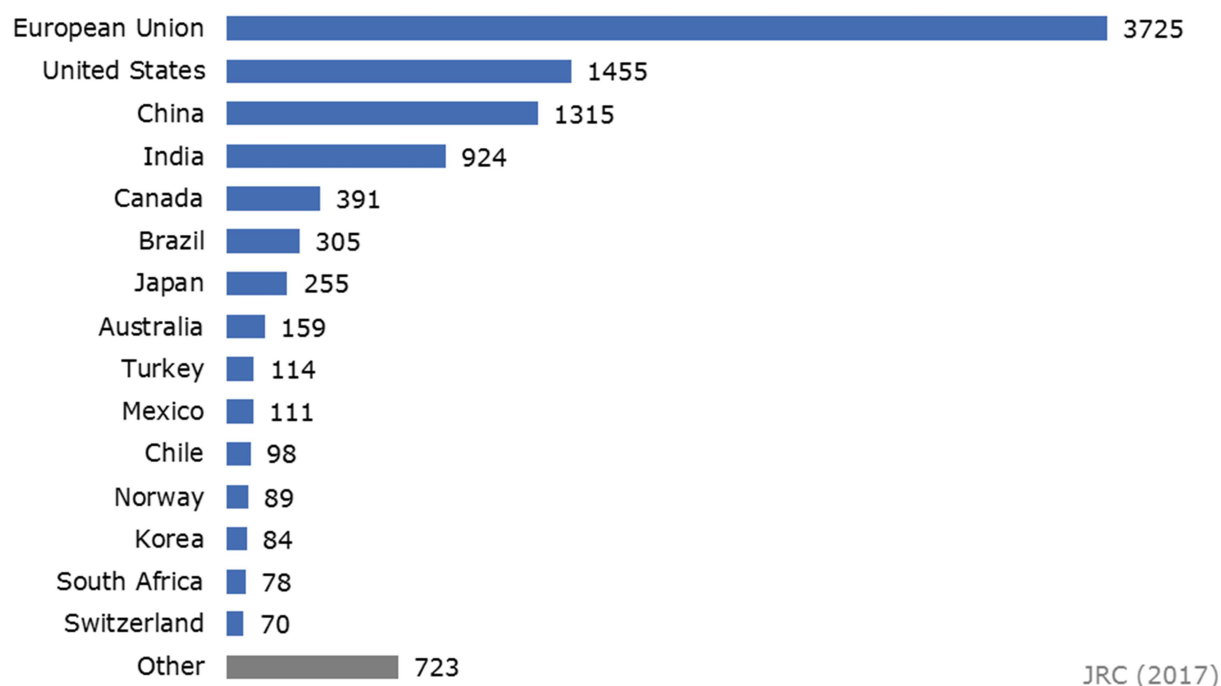

Source: (Bloomberg New Energy Finance (BNEF), 2016)

In Figure 8, the number of companies active in a relevant sector of wind energy is shown for the top 15 sectors (sectors with largest number of companies). Clearly, the highest shares of companies are project developers, followed by utilities and utilities that are project developers themselves. Power project SPVs (special-purpose vehicle), wind turbine manufacturers, holdings and corporations as well as engineering contractors also play an important role.

Figure 9 shows an international comparison of the share of the top 15 activities. The European Union ranks first in most activities, followed by the United States and China. The EU is slightly underrepresented in the categories blades and towers but is strong in utilities, power project SPVs, engineering/technical services, and investors. A trend towards specialisation on a global level cannot be observed except for the fact that China is showing a focus on blades and India is hosting a large share of holdings and corporations.

Figure 8. Number of companies according to the top 15 activities in the wind energy sector worldwide

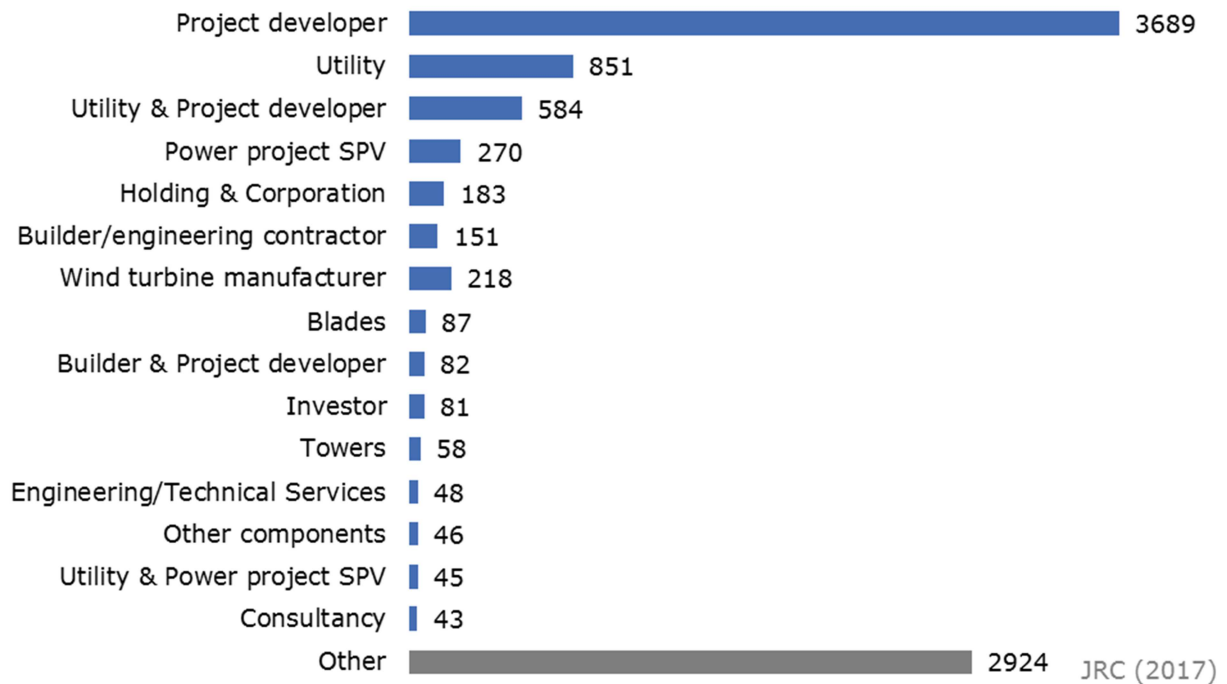

Source: (Bloomberg New Energy Finance (BNEF), 2016), adapted

Figure 9. Top 15 activities in the wind power energy sector, international comparison

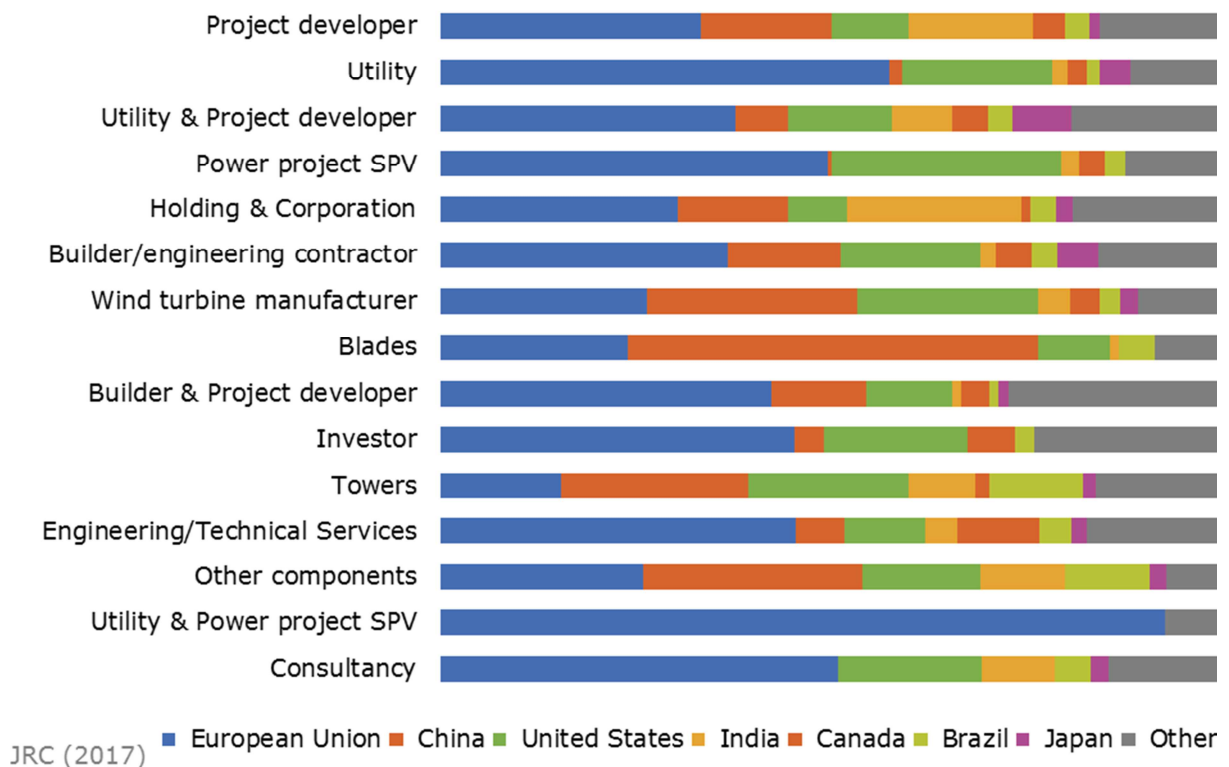

Source: (Bloomberg New Energy Finance (BNEF), 2016), adapted

2.3 Supply of the main wind turbine components

The purpose of this section is to analyse the potential strengths and weaknesses of the European manufacturing capabilities of the main wind turbine components. Thus, the current maximum European manufacturing capabilities are presented and compared with the annual wind energy development estimated in different modelling scenarios.

Firstly, the European manufacturing capabilities are compared with the annual estimated deployment in Europe with the aim of detecting possible bottlenecks in the future supply of the single wind turbine components in Europe. Secondly, European manufacturing capabilities are contrasted with the annual estimated deployment in the world with the purpose to identify the present and future potential market volume for single components outside the EU and to which extent this may be supplied by European manufacturers.

Three scenarios have been selected aiming to represent the future deployment of wind energy according to a business as usual situation, a moderate deployment and an optimistic deployment:

- Baseline scenario (IEA ETP 2016 6DS): Business as usual, i.e. extension of the current trends. It represents a less optimistic scenario in wind energy deployment in 2020 and 2030 at both European and global level (IEA, 2015).
- Market scenario (BNEF NEO 2017): there are only market-based incentives beyond 2020. It represents an intermediate expansion of wind energy deployment in 2020 and 2030 (BNEF, 2017).
- Decarbonisation scenario (IEA ETP 2017 B2DS): the climate targets are met and there is a strong policy and global coordination. It represents the most optimistic scenario in wind energy deployment in 2020 and 2030 at both European and global level (IEA, 2017).

Additionally, the EU reference scenario 2016-PRIMES has been used in order to compare the European manufacturing capabilities with the European wind energy deployment projected in 2020 and 2030.

Figure 10 shows the current maximum European annual manufacturing capabilities in comparison with the current and estimated European annual wind energy deployment.

Figure 10. Comparison of the current European annual manufacturing capability (GW) by wind turbine component with the current and estimated European annual deployment

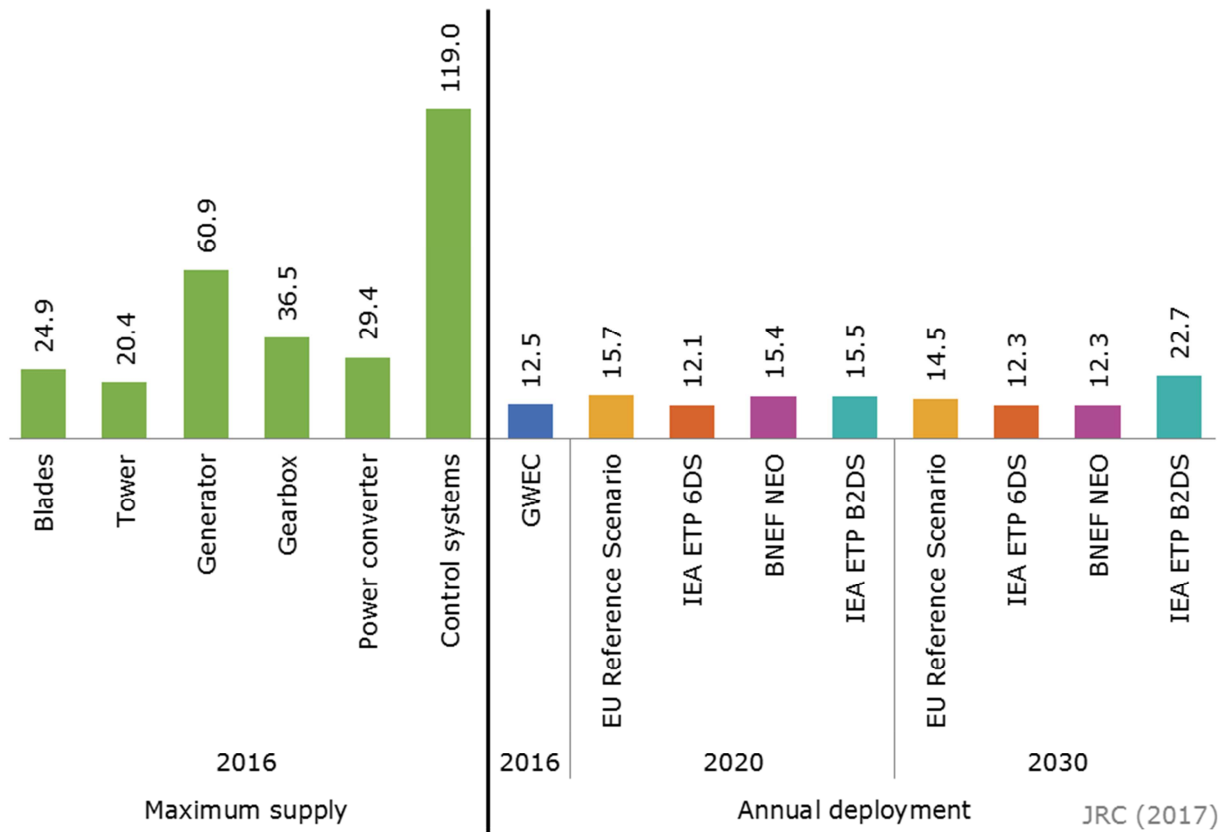

Sources: (Anonymous, 2016; BNEF, 2017; FTI-Consulting, 2016; GWEC, 2016; IEA, 2015, 2017)

European countries added a capacity of about 12.5 GW to the grid in 2016 (GWEC, 2016). This annual rate is estimated to range between 12.1 and 15.7 GW/year in 2020 and between 12.3 and 22.7 GW/year in 2030 based on the different scenarios.

If the maximum European manufacturing capabilities remain stable over the years, Europe shows manufacturing overcapacities in all key wind turbine components to cover the annual deployment in the short to medium term. Thus, no supply bottlenecks are expected that could hinder European wind energy development.

Figure 11 shows the current European annual manufacturing capabilities of the key wind turbine components in comparison with the worldwide wind energy deployment in 2016 and the estimated deployment in 2020 and 2030.

At global level, 54.6 GW of new capacity were installed in 2016 (GWEC, 2016). This annual rate is estimated to range between 48 and 85 GW/year in 2020 increasing up to between 55 and 137 GW/year in 2030 based on the different scenarios.

Figure 11. Comparison of the current European annual manufacturing capability (GW) by wind turbine component with the current and estimated worldwide annual deployment

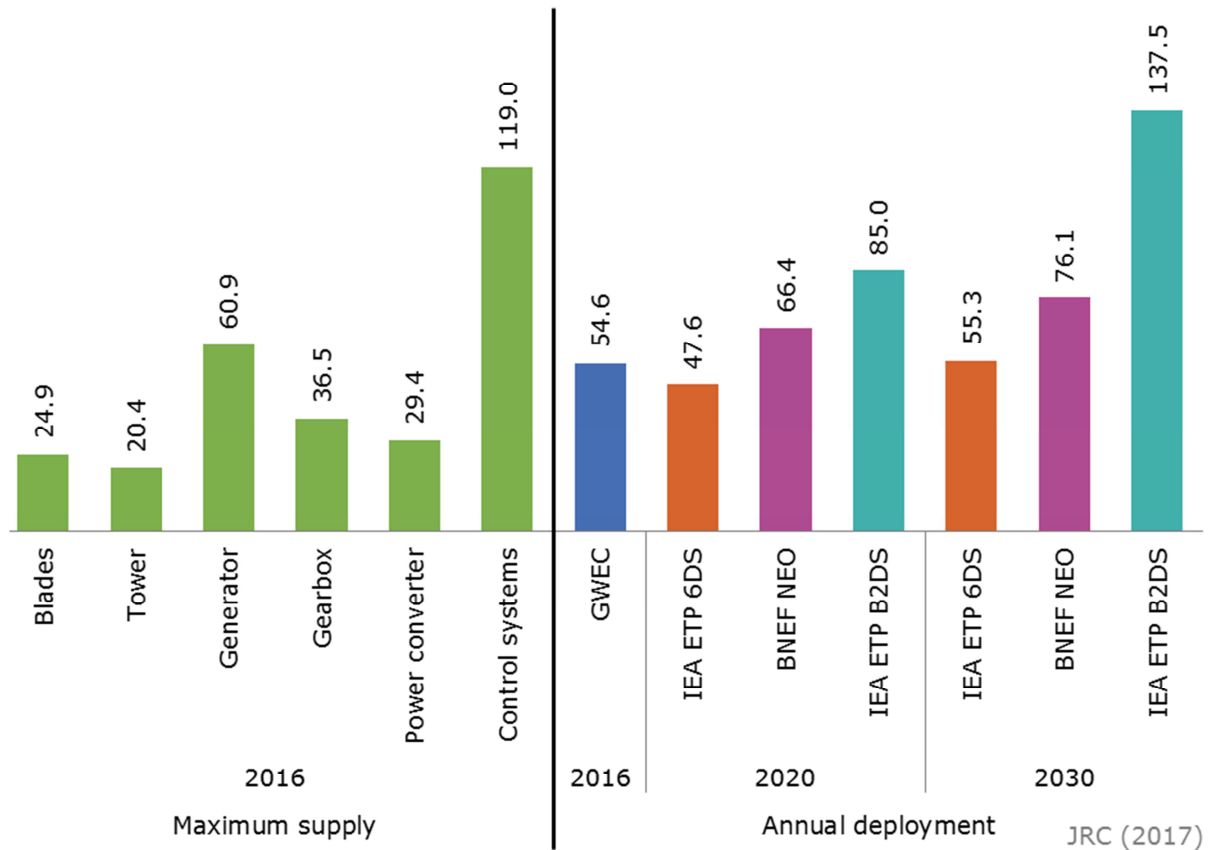

Sources: (Anonymous, 2016; BNEF, 2017; FTI-Consulting, 2016; GWEC, 2016; IEA, 2015, 2017)

Based on the current figures, Europe shows high manufacturing capacities of generators and control systems when they are compared with the global context. Nevertheless, this can be explained by the fact that these standard components are not exclusively used by the wind industry.

If Europe maintains manufacturing capabilities at current levels, it may be able to cover the global demand of control systems in most wind energy deployment scenarios as well as the global demand of generators in a business as usual scenario (IEA ETP 2016 6DS) up to 2030. Moreover, the global deployment rates of the market scenario (BNEF NEO) and the decarbonisation scenario (IEA ETP B2DS) indicate that there may be an additional market potential for European manufacturers producing exportable wind energy components.

The importance of each wind turbine component within the installation phase of the supply chain can also be estimated by the capital expenditure (CapEx) of the single component of the wind turbine.

Figure 12 depicts the breakdown of the CapEx for a characteristic onshore wind turbine (Moné et al., 2017). With about 23 %, the most significant impact on CapEx is found for the generator, the power converter and the control systems as well as the tower component. The gearbox, shafts and bearings account for 19 % followed by the blades with about 17 %. The remainder (pitch drives, nacelle, hub and yaw drives and yaw bearing) have a minor impact on cost totalling up to 18 %.

Figure 12. Breakdown of CapEx by wind turbine component

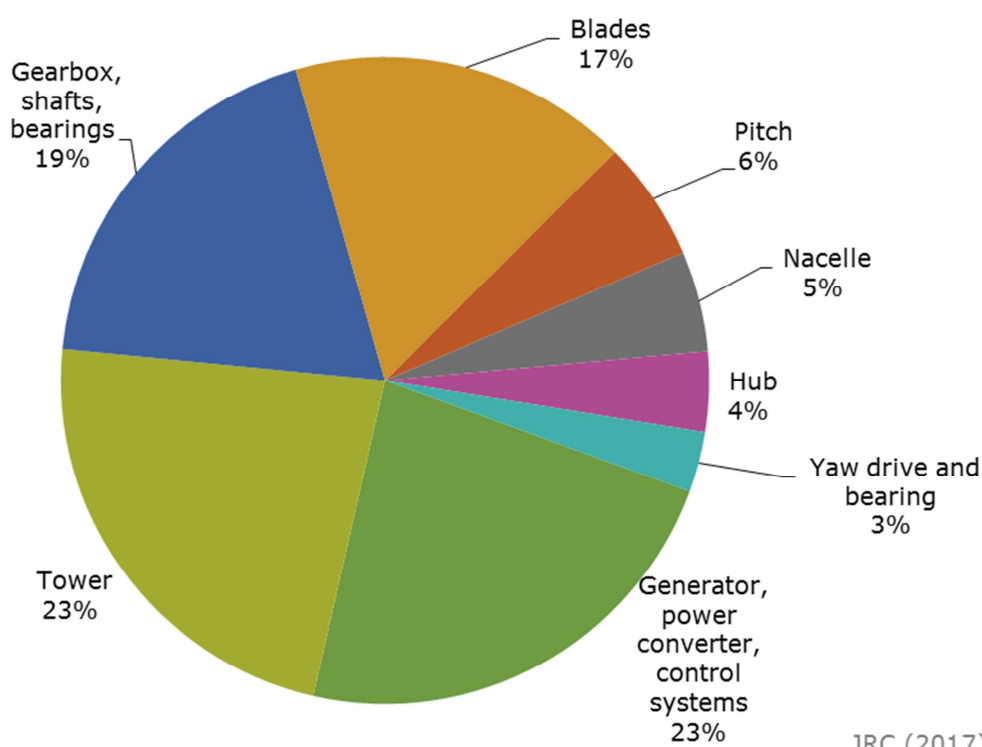

Source: (Moné et al., 2017)

In the following sections, a more detailed analysis on the main players for the individual components is presented.

2.3.1 Blades

Blades are one of the most critical and expensive components of the wind turbine. Currently there are about 20 OEMs in the world manufacturing blades in-house and supplying around half of the global demand for blades. Around 30 independent blade manufacturers meet the remaining demand.

Blade supply is changing over the years. Since the boom of the Chinese wind energy market, the global market share of in-house blade production has fallen. Consequently, outsourcing has gained popularity among the OEMs as it offers them flexibility in emerging markets. Furthermore, market consolidation is taking place including some examples such as the recent acquisition of LM Wind Power (the largest independent blade supplier) by GE Renewable Energy.

Among turbine OEMs that manufacture their own blades in-house, the European companies Vestas (DK), Siemens (DE) and Enercon (DE) are leading in manufacturing capacity. According to their maximum annual production capacity, the largest independent suppliers of blades are LM Wind Power (DK), Sinoma Wind (CN) and TPI Composites (US). Although the world's largest independent supplier LM Wind Power is European, more than half of the independent suppliers are Chinese.

Currently the market does not experience overcapacity as an industry shift to blade sizes above 50 m is ongoing, which will require proper investment in larger modules to avoid potential supply bottlenecks. The highest manufacturing capacity is located in the Asia Pacific region which is expected to show the greatest demand until 2020 (FTI-Consulting, 2016).

2.3.2 Drive train

Wind turbines can be classified based on the drive train components: gearbox (geared or gearless), electric generator (synchronous or asynchronous) and power converter (partial, full or none). The different types of drive train configurations shown in Figure 13 are a redefinition of the classification provided by (Hansen, Iov, Blaabjerg, & Hansen, 2004). Further information is available at: (Lacal Arántegui & Serrano González, 2015; Serrano-Gonzalez & Lacal-Arántegui, 2016).

In summary, types A, B and C correspond to the conventional geared high-speed wind turbines, type D is the direct drive configuration and types E and F represent hybrid arrangements.

Figure 13. Wind turbine types according to drive train configuration

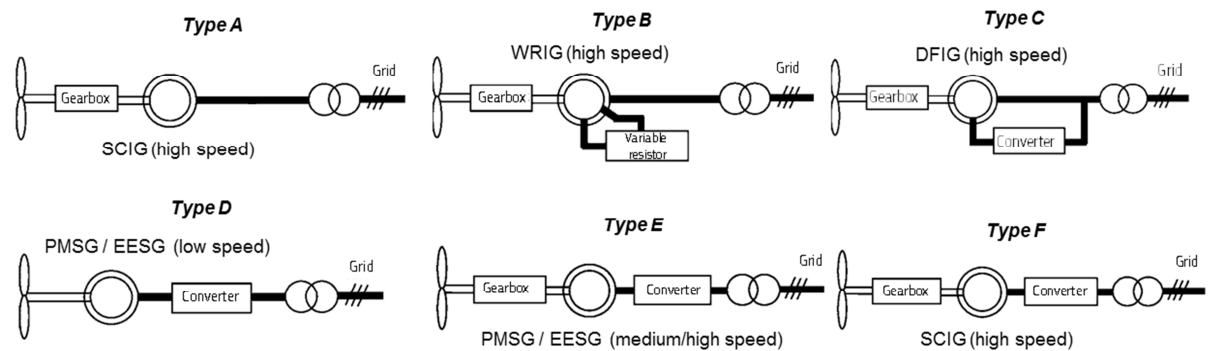

- | | | |
|---|--|------------|
| A | Geared and high-speed SCIG (Squirrel Cage Induction Generator) | |
| B | Geared and high-speed WRIG (Wound-Rotor Induction Generator) | |
| C | Geared and high-speed DFIG (Doubly-Fed Induction Generator) | |
| D | Direct drive configuration and low-speed PMSG (Permanent Magnet Synchronous Generator) or EESG (Electrically Excited Synchronous Generator) with full power converter. Type D-PMSG has PMSG and Type D-EESG has EESG | |
| E | Geared and medium/high-speed PMSG (Type E-PMSG) or EESG (Type E-EESG) with full power converter | |
| F | Geared and high-speed SCIG with full power converter | JRC (2017) |

Sources: (Hansen et al., 2004; Lacal Arántegui & Serrano González, 2015; Serrano-Gonzalez & Lacal-Arántegui, 2016), adapted

As shown in Figure 14, the global wind market is mainly dominated by conventional geared high-speed wind turbines with type C configuration and to a lesser extent by direct drive configuration type D, especially in Europe and Asia.

Hybrid arrangements have progressively gained ground in the last years although in a different way among geographical zones. Type E configurations are more installed in Europe while type F configurations are more common in North America. The conventional geared high-speed wind turbines with type A and B have steadily decreased and they currently represent a marginal market share (Vázquez Hernández et al., 2017).

Most of type D and type E configurations in the Asian market use PMSGs while EESGs are more common in Europe.

Figure 14. Evolution of the share of installed capacity by drive train configuration in onshore wind turbines by geographical zone

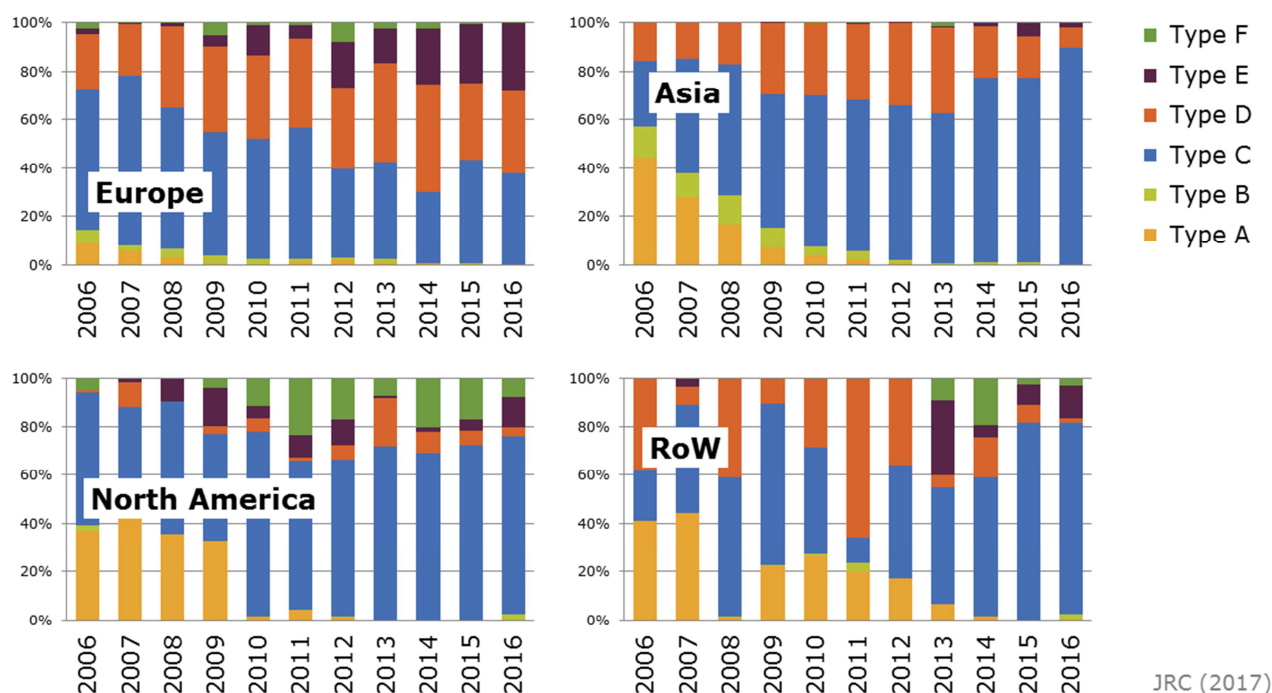

Source: JRC Wind Energy Database

JRC (2017)

2.3.2.1 Power generator

The power generator converts mechanical power into electrical power. Currently, most OEMs have in-house manufacturing capacity for power generators although independent generator suppliers supply more than one third of market share of the wind turbines generators.

The global market is currently led by the DFIGs followed by the PMSGs. In 2015, they accounted for 69 % and 18 %, respectively (FTI-Consulting, 2016). European manufacturers lead conventional geared high-speed wind turbines. In 2016, Vestas (DK), GE Renewable Energy (US) and Gamesa (ES) were the top three suppliers, followed by Nordex (DE) and United Power (CN). Enercon (DE) leads the supply of EESGs (only for direct drive trains or type D-EESG).

Goldwind (CN) is the world's largest supplier of PMSGs direct drive generators, securing about 63 % of the market for this configuration. Siemens (DE) replaced Chinese supplier XEMC as the second largest PMSG direct drive supplier in 2016 (FTI-Consulting, 2017).

The offshore wind market is currently dominated by SCIG (Siemens) and DFIG (MHI Vestas and Senvion) generators. Nevertheless, this situation is expected to change as more and more OEMs have adopted PMSGs (either in type D or E) for their next generation wind turbines (FTI-Consulting, 2016).

2.3.2.2 Gearbox

As blades, the gearbox is one of the most critical components of the wind turbine as it connects the low-speed shaft to the high-speed shaft to increase the rotational speed and helps to convert the rotational energy into electrical power. Besides, it is one of the most expensive components of a wind power plant with high reliability requirements as gearbox failures lead to the most significant downtime.

Most major OEMs using geared drive trains tend to outsource their gearbox supply with the exception of Gamesa. Enercon is the only OEM in the top 10 that currently does not use gearbox for any of its wind turbines as it only uses direct drive turbines.

In recent years the gearbox market was characterised by market consolidation. Currently there are only approximately 24 gearbox suppliers worldwide. The Chinese firm, NGC was the world's largest gearbox supplier in 2015 in terms of delivery. ZF (DE) took over the gearbox segment of Bosch Rexroth AG (DE) making it the largest gearbox supplier in Europe overtaking Winergy (DE) which is a subsidiary of Siemens (Winergy, 2017).

The offshore wind energy market is challenging for gearbox suppliers mainly due to the use of direct drivetrains in the most recent Siemens wind turbine designs (FTI-Consulting, 2016).

2.3.2.3 Power converter

The power converter controls the power flow and is used to optimise the energy production of a wind turbine.

Depending on the drive train arrangement different types of power converter are in use. Two types of power converters dominate the market, the partial rate power converter used in geared turbines with DFIG (type C drive train configuration in Figure 13) and the full power converters used in direct drive and the hybrid drive configurations (types D, E and F in Figure 13).

Apart from Envision (CN), the top 10 turbine OEM are manufacturing their power converters in-house. Among the largest independent suppliers ABB (CH) and Ingeteam (ES) can be found, with a manufacturing capacity above 10 000 MW/year. In total there are approximately 25 independent suppliers based in Asia Pacific, 11 in Europe and 6 in North- and South-America.

Power converters for offshore wind are predominantly manufactured in-house by the market leaders Vestas (DK) and Siemens (DE). Only 25 % of the offshore market is supplied by independent manufacturers (FTI-Consulting, 2016).

2.3.3 Towers

The tower has low technical requirements compared to other components so that it is usually sourced locally. China leads in terms of number of tower suppliers as it is the country with the highest number of new installed turbines

Currently there are more than 100 tower suppliers in the world although only 30 are European. Nevertheless, European suppliers lead in terms of wind tower innovation, including hybrid concrete/steel towers, pre-fabricated concrete towers or segmented large diameter steel towers, among others (Azar, 2015), (de Vries, 2016), (Dvorak, 2016) (Weston, 2016), (Wind Power Monthly, 2016), (Sritharan, 2015).

Currently there is an overcapacity in the global supply, a development that is expected to continue in the short-term. Nevertheless, there is a regional imbalance in terms of geographical distribution of manufacturing capacity as only China and Europe can supply the estimated demand in 2020.

Offshore wind towers have higher technical requirements than onshore towers as anti-corrosion and repair solutions must be implemented. This reduces the number of manufacturers capable of supplying offshore wind turbine towers. European offshore wind tower manufacturers are based in Germany and Denmark (FTI-Consulting, 2016).

2.3.4 Other electrical components (control systems and transformers)

All major turbine OEMs produce control systems in-house to optimise their turbines. About two-thirds of the remaining independent control system suppliers are based in Europe. The market for control systems of new turbines is more restricted as the turbine OEMs tend to protect their Intellectual Property of this component. However, independent manufacturers of control systems might benefit from a growing retrofit market in case that a complete repowering of older turbines is not possible or economic due to stricter regulations in place.

Transformers are used in wind energy plants to transfer the energy generated by the turbine to a higher voltage to feed it into the distribution network. Being a common power transmission product, power transformer suppliers are located across all major markets. 19 of them are from Europe, 19 are from Asia Pacific, and 12 are from North and South-America (FTI-Consulting, 2016).

Offshore wind power transformers are mainly manufactured by European companies. Main European suppliers are CG Power Systems (BE), ABB (CH), Siemens (DE), SGB-SMIT Group (DE) and Schneider Electric (FR). As a consequence of the recently growing offshore wind market in Asia, local manufacturers such as Hitachi (JP), Risho Kogyo (JP) and AVIC Quingdao Yunlu (CN) appeared.

2.3.5 Other parts of the supply chain with lower impact on turbine costs

- Pitch drives: The leading electric pitch drive suppliers are in Italy and Germany whereas the leading hydraulic pitch drive suppliers are in Denmark, Spain and Germany (FTI-Consulting, 2016).
- Yaw drives: The leading yaw drive suppliers are in China, Germany and Italy (FTI-Consulting, 2016).
- Brake system: The leading brake system suppliers are in China and Germany. China takes the lead in terms of numbers of suppliers whereas the European suppliers lead in terms of product quality and global footprint (FTI-Consulting, 2016).
- Nacelle housing and spinner covers: The leading suppliers are located in Denmark, Germany and Spain (FTI-Consulting, 2016).

2.3.6 Offshore wind balance of plant

The offshore wind balance of plant (BOP) covers all components and equipment associated with the construction of an offshore wind farm. The European supply chain is becoming increasingly mature across all subcomponents (e.g. foundations, offshore substations, cables, installation vessels). Europe leads in the supply of offshore wind BOPs, however with offshore wind project construction taking place outside EU (Asia/Pacific and North America) BOP suppliers have also emerged in China, South Korea and the US (FTI-Consulting, 2016).

3 Geothermal energy

The supply chain of geothermal can be divided in three main parts: planning, installation, and operation & maintenance (Bracke et al., 2008; Richter, Thompson, Ko, & Dunn, 2013; Thompson, Davis, Richter, Ko, & Ryan, 2013). In addition to those core sectors, upstream production of components and materials also takes place. Figure 15 shows an example for the case of shallow geothermal energy. In Figure 16, a slightly different view is adapted for the example of deep geothermal energy. In the following section, we will address the geothermal energy supply chain separately for power production, direct use and ground source heat pumps.

Figure 15. Supply chain for geothermal energy systems: example for shallow applications

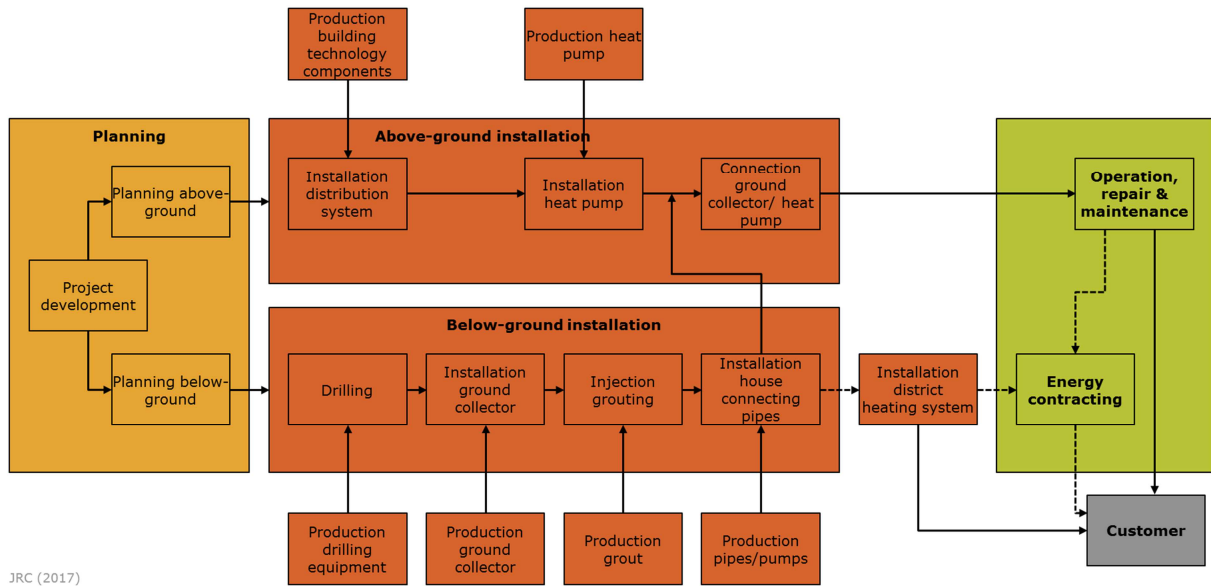

Source: (Bracke et al., 2008), simplified and adapted

Figure 16. Supply chain for geothermal energy systems: example for deep applications

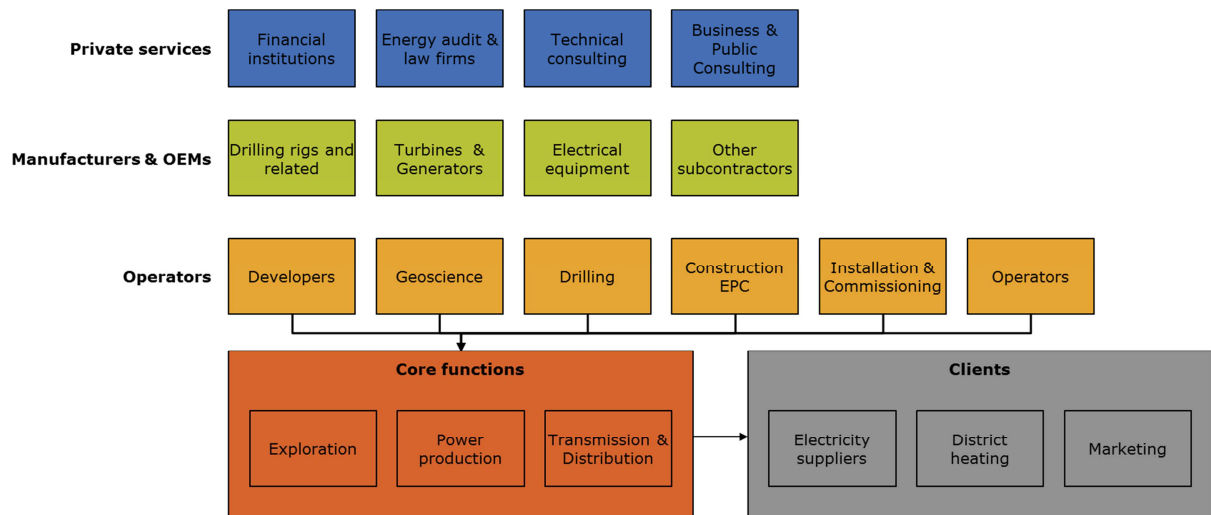

Source: (Geoelec, 2014), simplified and adapted

3.1 Geothermal power

The costs of a geothermal power plant are usually dominated by exploration & drilling and the power plant with the surface installations (Angelino, Dumas, & Pinzuti, 2017; Sigfússon & Uihlein, 2015). In the following section, we will assess the market of individual components such as power turbines but also other parts of the supply chain.

3.1.1 Power turbines

Geothermal power plants are currently installed in eight European countries of which six EU-28 Member States (Figure 17). Capacity additions in recent years took mainly place in Turkey where a strong growth can be observed from about 220 MW in 2012 to about 870 MW at the end of 2016 (Shortall & Uihlein, 2017).

The global market in geothermal power is dominated by four major manufacturers (Toshiba, Mitsubishi, Ormat, Fuji) accounting for about 80 % of the installed capacity (Annex et al., 2016). In Europe, Ansaldo-Tosi leads the market with about 30 % of installed capacity (Figure 18). Other prominent players in Europe are Mitsubishi-Turboden, Fuji, Ormat, and GE/Nuovo Pignone. Ansaldo-Tosi and GE/Nuovo Pignone are mainly active in Italy with capacity installed in hydrothermal power plants existing since a very long time.

Figure 17. Installed capacity of European geothermal power plants in 2016

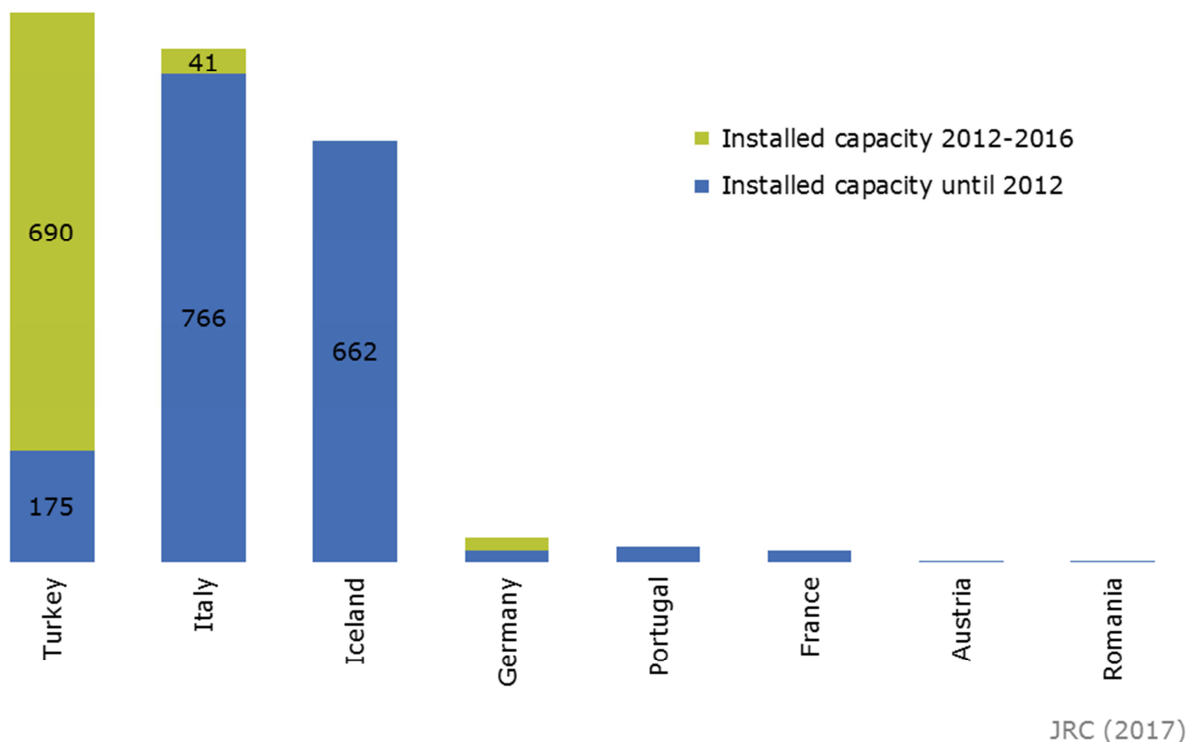

Source: (Shortall & Uihlein, 2017)

The European market is still dominated by conventional dry steam/flash technology (65 % of installed capacity). However, the majority of recent installations are binary power plants. The main turbine suppliers after 2012 are Ormat (34 % market share, followed by Exergy and Atlas Copco with 22 % and 19 % of market share, respectively (**Figure 18**).

Figure 18. Market share of turbine manufacturers in Europe (left: total installed capacity; right: capacity additions after 2012)

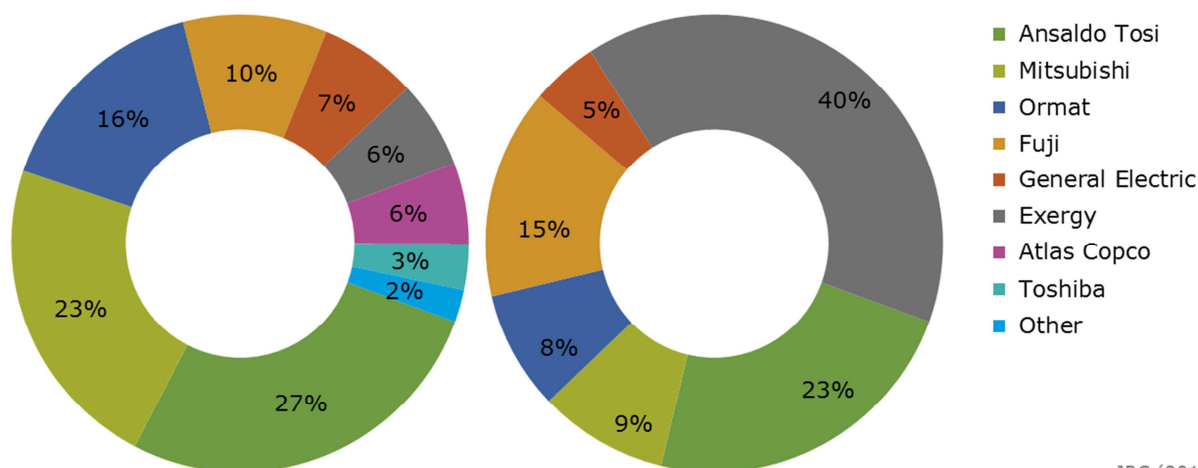

JRC (2017)

Sources: (Angelino et al., 2017; Shortall & Uihlein, 2017)

Ormat (USA), Turboden (Italy), and Exergy (Italy) have a strong position in binary-ORC markets in terms of total installed capacity. New actors are entering the market or strengthen their market position since a few years (e.g. Atlas Copco, Cryostar (Switzerland), Green Energy Geothermal (UK)). We see a development towards turbines that can be ramped down and up to provide more flexibility for the grid. In conventional geothermal (dry steam/flash), the market is dominated by the three main players from Japan (Mitsubishi, Toshiba, Fuji). Ansaldo (Italy) on rank 4 and General Electric/Nuovo Pignone (Italy) are following. This market segment is highly competitive and it is very difficult for new players to enter the market.

3.1.2 Other parts of the supply chain

From BNEF, a list of organisations active in the geothermal power sector is available (Bloomberg New Energy Finance (BNEF), 2016). The largest share of organisations can be observed in the United States (about 300 organisations), followed by the EU (about 225 organisations). Next are Australia, and Canada (Figure 19). The results are biased towards the USA and English-speaking countries (since BNEF has a strong focus on news and information published in English) this has to be kept in mind. Other countries that are main players in the geothermal power sector, such as Indonesia, Japan, Philippines, and Iceland) are appearing also on the list of the top 15 countries.

Figure 19. Organisations in the geothermal power energy sector according to country

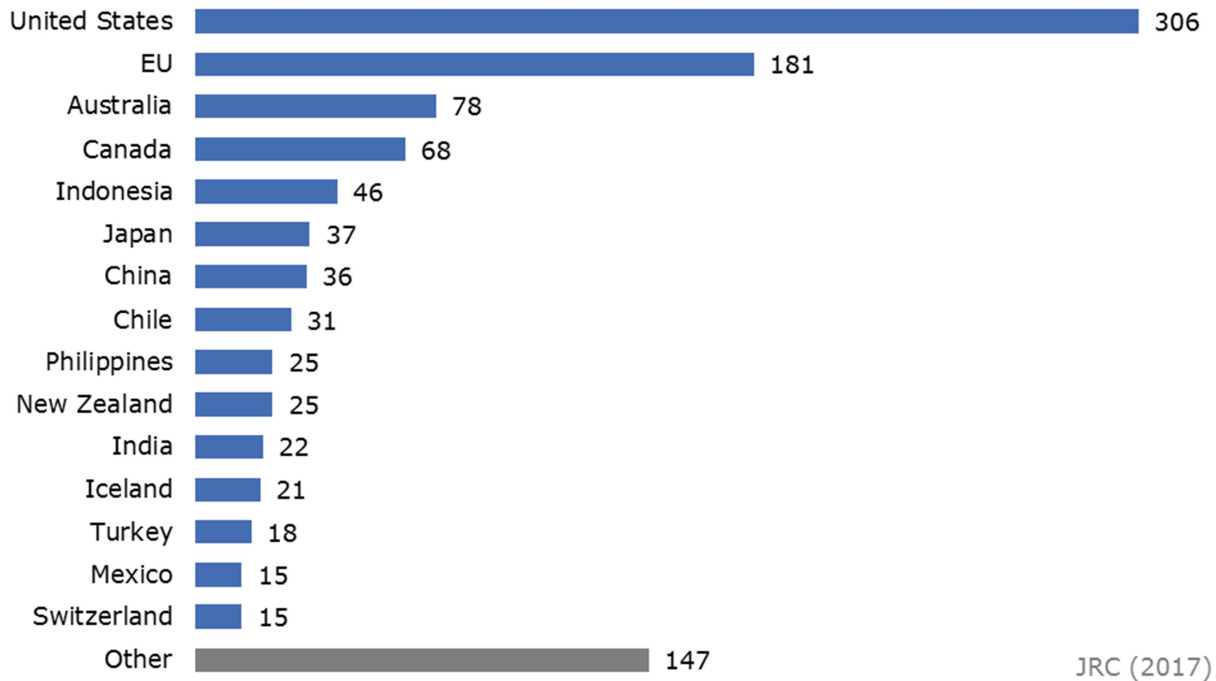

JRC (2017)

Source: (Bloomberg New Energy Finance (BNEF), 2016)

In Figure 20, the number of companies active in a relevant sector of geothermal energy is shown. Clearly, the highest shares of companies are project developers, followed by utilities that are project developers themselves, and utilities (which are often also operators of geothermal fields/power plants). Exploration & Drilling and also University/Research organisations play a big role on a global level.

Figure 20. Number of companies according to main activities in geothermal power worldwide



JRC (2017)

Source: (Bloomberg New Energy Finance (BNEF), 2016), adapted

Figure 21 shows the country share of the top 15 activities. The United States rank 1st in most activities, followed by the European Union. In Figure 21, one can see that the EU is disproportionately underrepresented in the categories exploration & drilling and investors but is strong in geothermal energy systems and heat pumps. Interestingly, on a global level specialisation can be observed, with for example Indonesia showing a great share of companies active in both engineering services & exploration/drilling, or Chile focusing on Engineering/technical Services.

Figure 21. Country shares of top 15 activities in the geothermal power energy sector

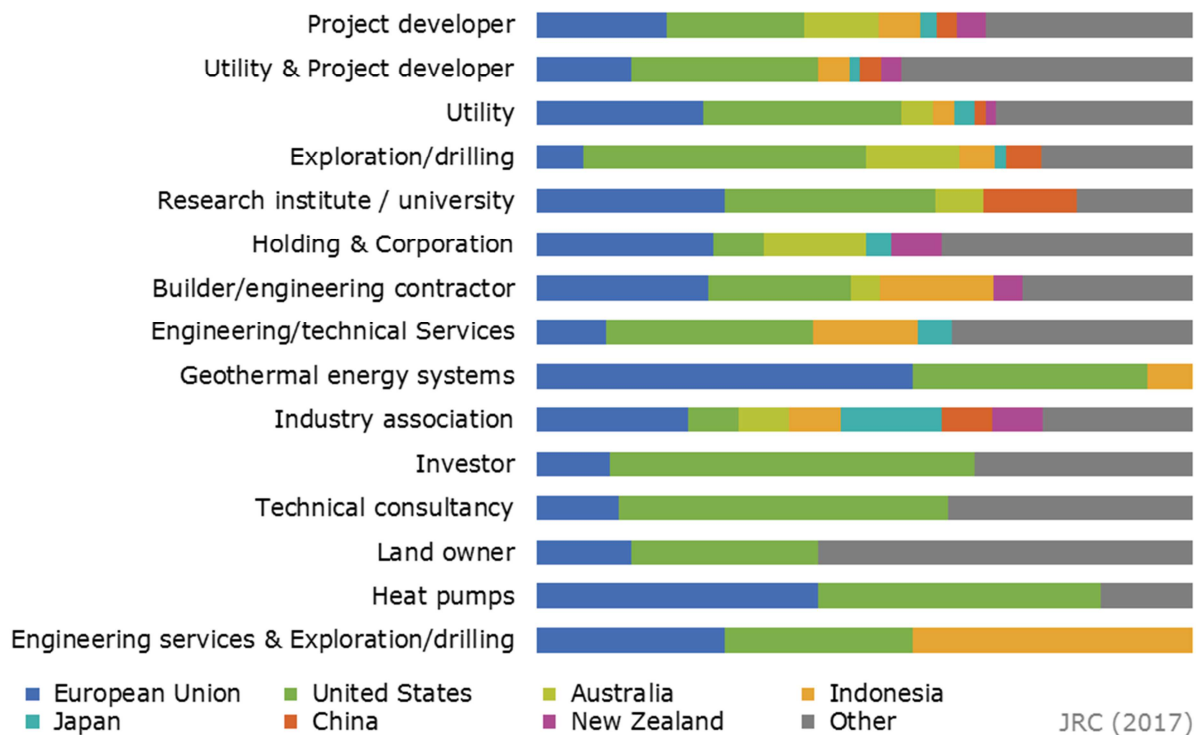

Source: (Bloomberg New Energy Finance (BNEF), 2016), adapted

Most suppliers of geothermal equipment for the underground part of the installations are coming from oil & gas industry (e.g. exploration, drilling, pipes, and pumps). Manufacturers from the conventional energy sector are the main suppliers for above-ground installations (e.g. turbines). Major providers for pumps, valves, and control systems include Schlumberger, Baker & Hughes, GE, ITT/Goulds, Halliburton, Weatherford International, Flowserve (all US), Canadian ESP (Canada), Borets (Russia) (Angelino et al., 2017). Heat exchangers are supplied mainly by Alfa Laval (Sweden), Danfoss (Denmark), Kelvion Holdings (Germany), SPX Corporation (US), Xylem (US), Hamon & Cie, Modine Manufacturing Company (US), SWEP International (Denmark).

As noted in (Goldstein & Braccio, 2014), while there are only a number of globally active project development companies, a number of niche players engaged in a specialised subsector have evolved ranging from exploration and confirmation of geothermal resources to O&M.

Production well drilling and facility construction are responsible for the majority of costs of a geothermal project. Globally, only a handful of companies are specialised in geothermal drilling only and about 20 more perform drilling in the oil, gas and geothermal sectors (Goldstein & Braccio, 2014). The market for facility construction (balance of plant) is very competitive.

When it comes to geothermal field operators or power plant operators, (Angelino et al., 2017) states that many of them are national (public) companies such as KenGen in

Kenya and CFE in Mexico. In addition, some large private operators exist, such as Calpine, TerraGenm, ENEL, Ormat. Most operators are thriving to expand their activity and aim at broadening their geographical footprint beyond their country of origin. Chevron, one of the biggest operators has announced to leave the geothermal sector and will sell its 1.3 GW installed capacity (Angelino et al., 2017).

3.2 Ground source heat pumps market

In Europe, the largest segment of geothermal energy is ground source heat pumps (GSHP). The total installed capacity reached 22.8 GW and GSHP have been installed in almost all EU Member States.

Currently Sweden has the largest market in terms of installed capacity (Figure 22) and in terms of units sold with about 5.8 GW capacity and 31 % of all units in the EU, followed by Germany with 3.9 GW of capacity and 19 % of installed units.

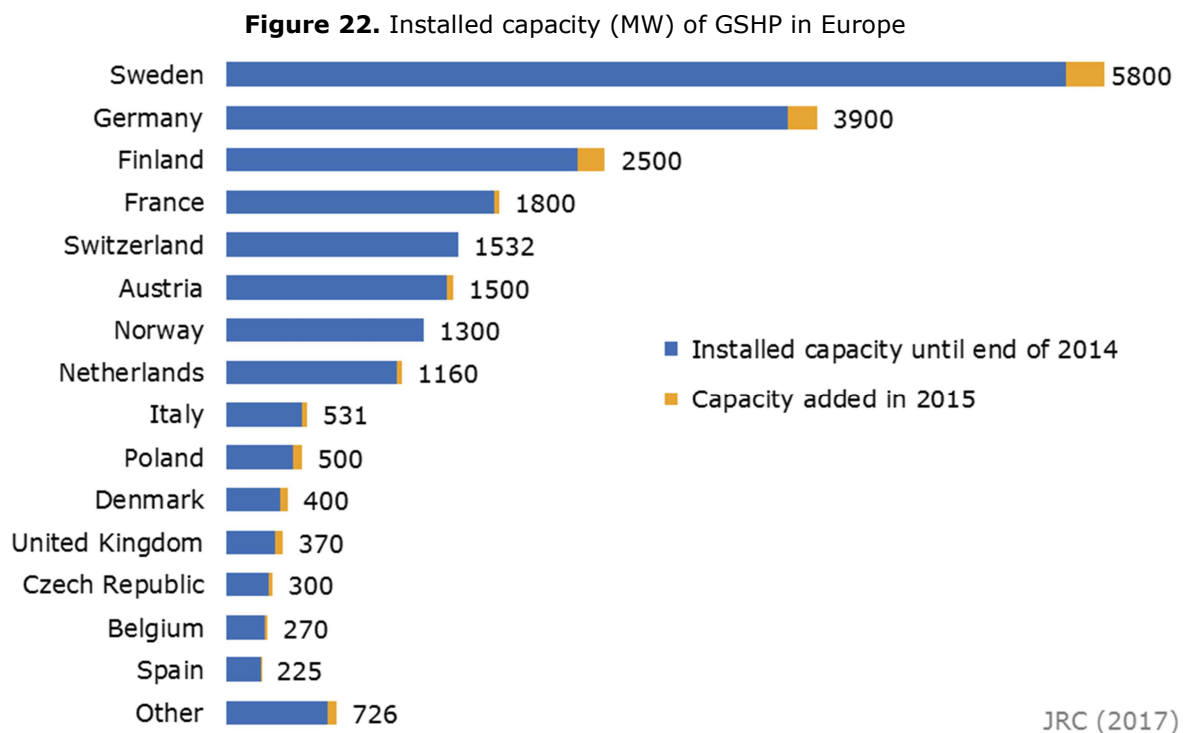

Sources: (Angelino et al., 2017; Antics, Bertani, & Sanner, 2016; EURObserv'ER, 2016), own analysis

Figure 23. Installed GSHP (1000 units) in Europe

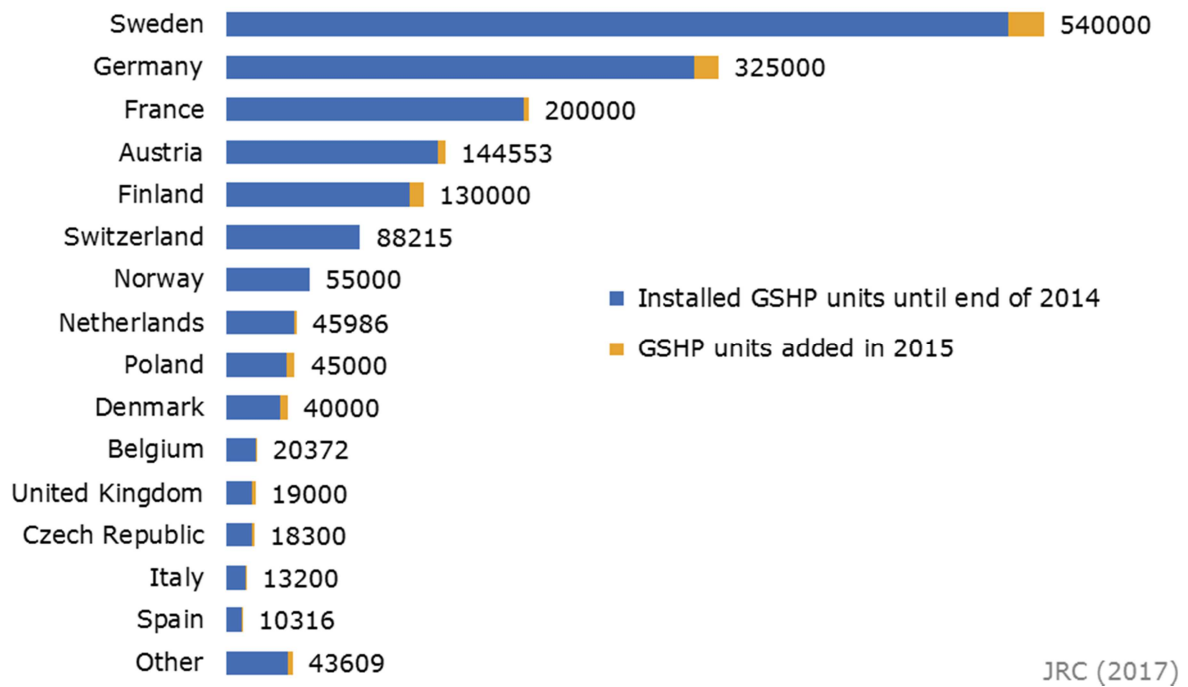

Sources: (Angelino et al., 2017; Antics et al., 2016; EURObserv'ER, 2016), own analysis

The European GSHP market has developed from a market with many small local companies to a market dominated by major heating and air-conditioning manufacturers (Nowak & Sara Jaganjacova, 2013). For GSHP, the main European players are listed in Table 2. Countries of origin of manufacturers very much mirror the main markets for GSHP with many big producers being from Germany and Sweden (Figure 22). Asian manufacturers which have been focussing on air/air heat pumps and air conditioning in the past are now more active on the European GSHP market. For example, Daikin recently launched a GSHP for residential usages while Mitsubishi's Ecodan GSHP systems target medium to large commercial installations (Daikin, 2014; Mitsubishi, 2014). Other manufacturers such as Samsung, LG, Panasonic and Hitachi seem not to have GSHP in their portfolio yet.

Table 2. Overview of major European GSHP manufacturers and brands

Company	Brand	Country	Capacity range (kW)	Comments
BDR Thermea (NL)	De Dietrich/ Remeha	France	5.7-27.9	10 000 heat pumps sold in 2014
	Baxi	UK	4-20	GSHP offer discontinued
	Brötje	Germany	5.9-14.9	
	Sofath	France	2.8-29.5	50 000 GSHP units sold so far
Bosch Thermo-technik (DE)	Junkers	Germany	5.8-54	
	Buderus	Germany	7-70	
	IVT Industrier	Sweden	6-16	Swan-labelled GSHP
Danfoss (DK)	Thermia Värme	Sweden	4-45	
Nibe (SE)	Alpha-InnoTec	Germany	5-30	Belongs to Schulthess (daughter of Nibe)
	Nibe Energy Systems	Sweden	5-17	Largest EU manufacturer of dom. Heating
	KNV	Austria	4-78	Acquired 2008. 13 000 heat pumps sold
Vaillant (DE)	Vaillant	Germany	6-46	Second largest HVAC manufacturer
Viessmann (DE)	Viessmann	Germany	5-2000	
	Satag Thermo-technik	Switzerland	3-19	Acquired in 2004
	KWT	Switzerland	6-2000	One of the pioneers in GSHP
Ochsner (AT)	Ochsner	Austria	5-76	130 000 heat pumps sold so far
Stiebel Eltron (DE)	Stiebel Eltron	Germany	4.8-56	Acquired 35 % of share capital of Ochsner

Source: JRC data

3.3 Direct use

Apart from ground source heat pumps, which take up the largest share of direct use applications, geothermal energy is directly used for the most part in space heating, followed by greenhouse heating, aquaculture, agricultural drying, for industrial uses and for bathing purposes (Lund & Boyd, 2015), however many other possible applications exist. Such direct-use technologies closely resemble geothermal electric systems, except the heat is used for another purpose (e.g., greenhouses, drying crops). Waste heat from electrical generation plants or heat-only geothermal plants could supply a district heating system, and then supply a cascade of applications requiring successively lower temperatures, for instance, greenhouses heating, followed by aquaculture applications, etc.

In Europe, the fastest growing geothermal direct use application is district heating (Angelino et al., 2017; GeoDH, 2014). In Europe, about 280 geothermal district heating systems are currently in operation (Angelino et al., 2017). In the EU, 190 geothermal district heating systems are in operation with a cumulative capacity of 1.7 GW and a production of about 4.3 GWh (Figure 24). Beyond the EU, the main players are Iceland and Turkey with about 2.2 GW and 0.8 GW installed capacity, respectively.

The main growth of geothermal district heating in Europe took place in the EU where capacity additions in the past years amounted to 0.5 GW with the main markets being France and Hungary, followed by Germany and the Netherlands.

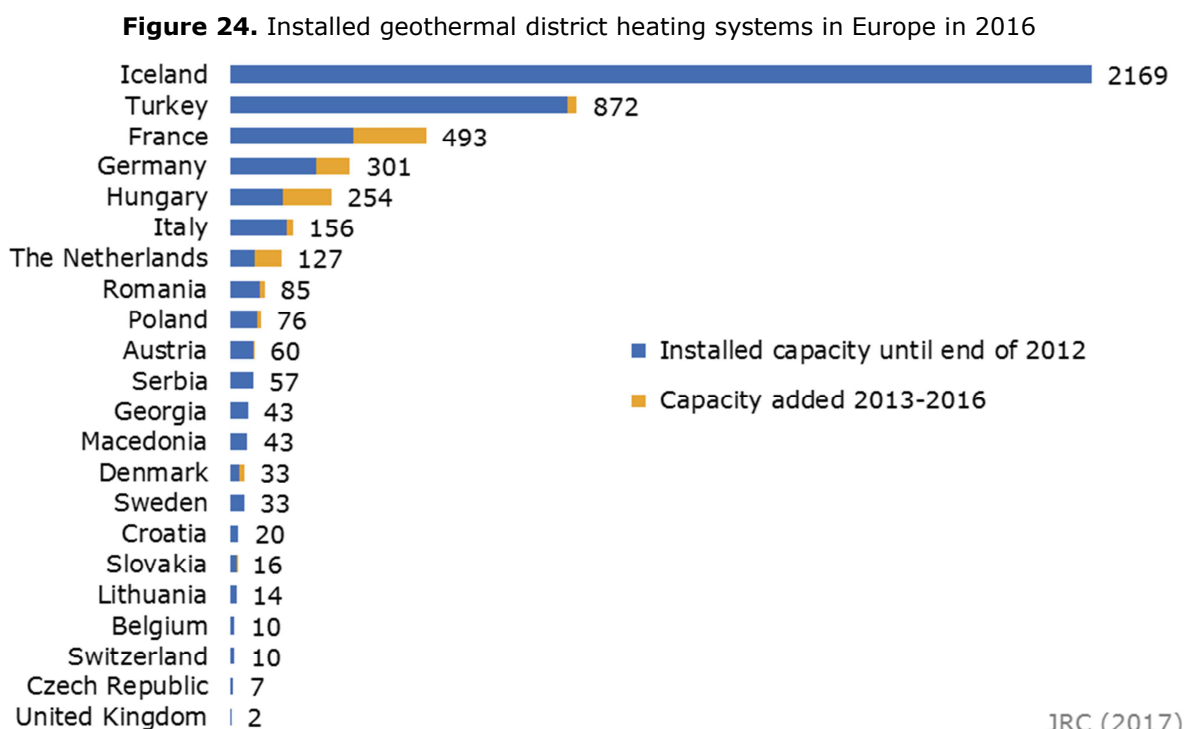

Source: (Angelino et al., 2017)

The primary components of most low-to-moderate temperature direct-use systems are well and circulation pumps, transmission and distribution pipelines, peaking or back-up plants, and various forms of heat extraction equipment. When the geothermal water temperature is warm (below 40 °C), heat pumps are often used [CANGEA 2014]. Only limited information is available about suppliers of systems and components for geothermal district heating. Often, suppliers of systems and components for geothermal district heating are the same companies providing equipment for the underground part of geothermal power projects. For the surface system, we find the same suppliers of systems and components (pipes, pumps and stations) as in the district heating industry.

4 Ocean energy

Ocean energy is an emerging energy sector comprised of a number of technology families at different state of the development, but yet to become commercially viable and competitive. In contrast to wind and geothermal energy, the supply chain for the ocean energy sector is not fully consolidated, and is dependent on the success of technology developers in delivering viable ocean energy converters.

The market for ocean energy is still nascent, with the different technologies having yet to reach a competitive level with other renewable energy sources. Cost-reductions are therefore necessary for the consolidation of the ocean energy market, and for the establishment of a large pan-European ocean energy supply chain.

The necessity of reducing the cost of ocean energy technology, also through economies of scale, implies that the presence of OEMs with access to large manufacturing facilities could be seen as an indicator of the consolidation of the supply chain. One of the critical issues for the ocean energy sector over the past few years has been the lack of engagement of OEMs.

The landscape is rapidly changing thanks to the technology validation projects currently ongoing in European test centres. Since 2016 a limited number of demonstration projects have been deployed in European waters, with the main goal of proving the reliable electricity generation of ocean energy technologies and to provide indication of the bankability of the technology in the long term. Some OEMs such as Naval Energy (DCNS), Lockheed Martin, AndritzHydro Hammerfest, are involved in the delivery of the projects providing tidal generators.

The data from the demonstration projects indicate that technology is working reliably with, in the case of tidal energy demos, capacity factors of about 40% and a considerable amount of electricity delivered to the grid. Whilst project development and the manufacturing of components and sub-components for demonstration projects are engaged on an ad-hoc basis; these projects are essential for removing technology risk. It is expected that OEMs are going to be attracted back to the sector as confidence in the technology grows.

It should be noted however, that at the current stage OEMs in the ocean energy sector rely on local suppliers for the delivery of the demonstration projects. The ability of successfully engaging with local manufacturers and service providers (such as vessels), is key to finalise ongoing and future projects.

European regions are well position to host wave and tidal energy developers, and could benefit from the growth of the ocean energy market. Naval Energies has already announced plans to open a manufacturing facility in Normandy. In Shetland, the commissioning of tidal energy turbines has already helped the expansion of a local company specialised in tidal blades. Manufacturing and assembly facilities for ocean energy deployment are expected to be located in high-resource areas, benefitting coastal regions the most.

Figure 25 presents an overview of the expected consolidated ocean energy supply chain ocean, emphasising the manufacturing of ocean energy converters and key components. Given the localised nature of wave and tidal energy resources, it is expected that ancillary activities such as project development, operations and maintenance, will be carried out by local companies. The manufacturing of ocean energy converters, as in the case of wind, will then play a fundamental role in shaping the technology market and in defining the positioning of European companies in the global market. Technology developers are already investigating markets where to expand their business plans in location that offer growth both in terms of manufacturing capabilities and deployment of their technologies.

Figure 25. Ocean energy supply chain accounting for component and subcomponents manufacturing

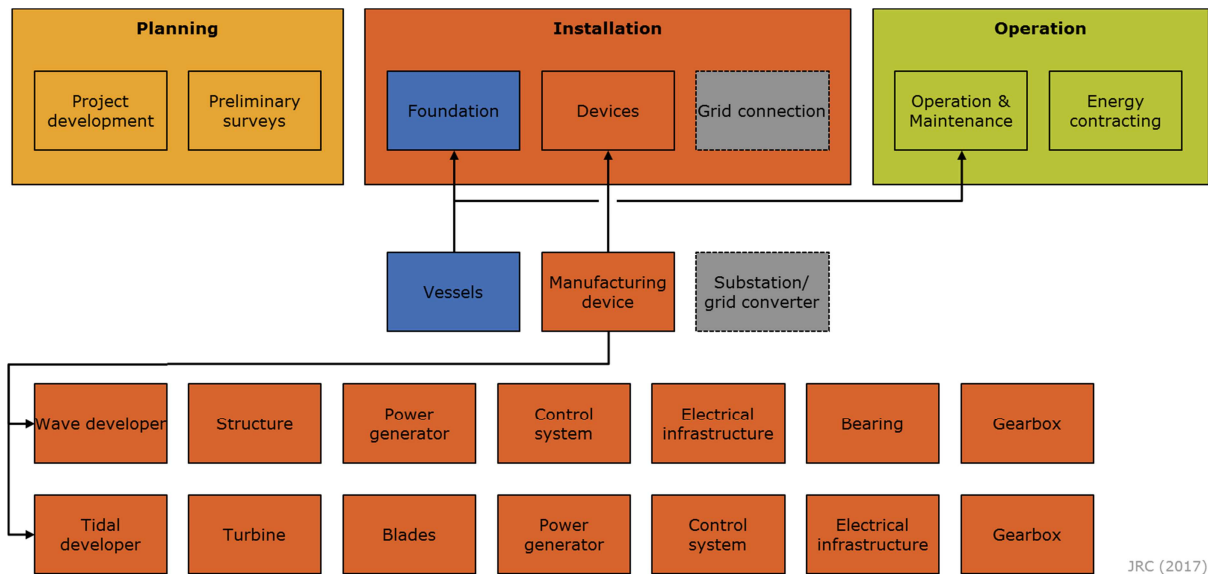

Source: JRC

To date, Europe maintains a leadership position in the development of ocean energy technology, hosting 52% of tidal and 60% of wave energy development (**Figure 26**). European leadership is also strengthened by the availability of 70% of the ocean energy infrastructure. European technology also maintains a leadership position with regards to installed capacity at a global level. Of the 16 operational tidal energy projects deployed worldwide 15 employ European technologies.

Figure 26. Share of tidal and wave energy developers at global scale in 2017

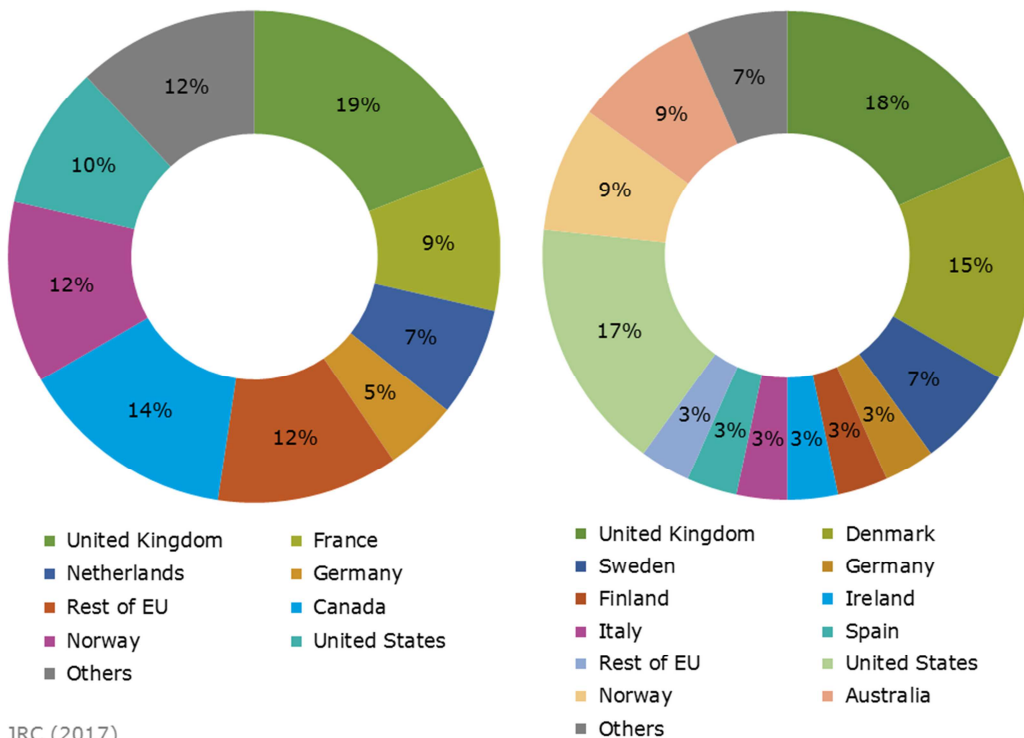

Source: (Magagna & Uihlein, 2017)

A list of organisations active in the ocean energy sector is available from BNEF, highlighting areas of activity of each company. Figure 27 presents a breakdown of companies involved in the ocean energy sector per activity, which highlights the availability of knowledge and experience available in the EU.

Figure 27. Share of organisations in the ocean energy sector classified per activity

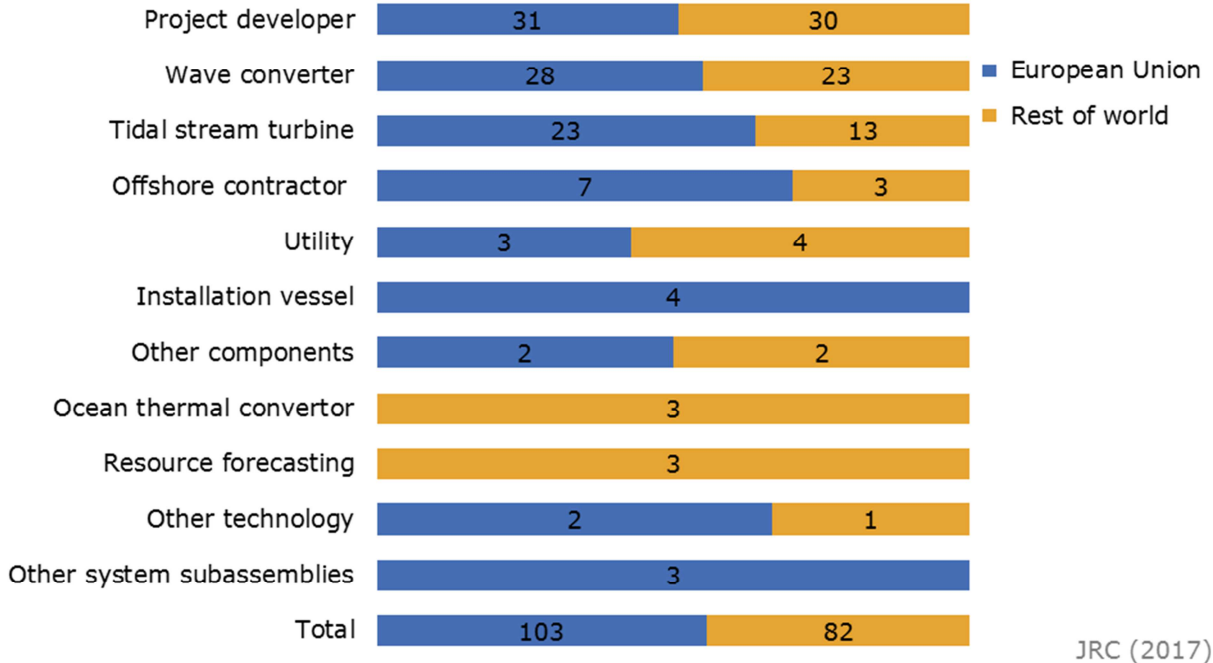

Source: (Bloomberg New Energy Finance (BNEF), 2016)

4.1 Tidal energy developers

The market for ocean energy technologies is yet to be fully established. First-of-a-kind pre-commercial tidal energy projects are currently taking place in Europe, Canada. All pre-commercial deployments employ European technology, aside from the 1.5 MW tidal converter developed by Atlantis Resource Limited (UK based) which is manufactured in conjunction with Lockheed Martin (US).

Key technologies developers in the sector are Atlantis Resources Limited, which has developed the 6 MW Meygen array, AndritzHydro Hammerfest (deployed 3 x 1.5 MW turbines at Meygen), OpenHydro (deployed 2x0.5MW turbines in France, and 1 x 2 MW turbine in Canada), Tocado (deployed 3 MW in Netherlands), Scotrenewables (2 MW converter in Scotland), Schottel (German developer producing 62kW turbines), NovaInnovation (deployed 1st tidal farm with power rating of 300 kW), Sabella (1 MW turbine).

The success of these projects combined with the predictability of the resources in Europe should allow for a rapid expansion of the tidal energy market in other areas such as Eastern Asia and South America.

4.2 Tidal components

Components for tidal energy converter are mainly provided on a bespoke or project by project based. Significantly most European developers have used EU manufacturers for the supply of key components such as drivetrains (Schottel and Siemens, when not developed in house), Gearboxes (Siemes, Bosch Rexroth, James Fishers Defence), Shafts (Schottel, Bosch Rexroth) and blades (Airborne Marine, Norco Ltd, AEL and Gurit).

Fabrication of the structure and of the foundation is normally sourced locally. A detailed component supply chain for key tidal energy developers is presented in Table 3.

Table 3. Detailed component supply chain for tidal energy converters

Developer	Blades	Bearings	Brakes	Shaft	Gearbox	Control	Generator	Electrical
Andritz Hydro/ Hammerfest	AEL			Schottel		In-house	In-house	Converteam
Atlantis Resoruce Limited	Norco Ltd	NKE	Altra Industrial Motions	Schottel				
Invo-tech	David Brown	Schottel	ATB Morley	ABB				
Nova Innovation					Siemens		Siemens	
OpenHydro	Norco Ltd						In-house	
Schottel		Wolfgang Preinfalk					In-house	
Scot-renewables	Designcraft	SKF		SKF	Siemens	MacArtney	In-house	ABB
Tocado	Airborne Marine						In-house	

4.3 Wave energy

In comparison with tidal energy, the wave energy industry has yet to reach pre-commercial deployments. Technology is currently being demonstrated at TRL7. Final designs of wave energy converters have still to be optimised, and as a consequence the supply of components is not consolidated. 2017 has already seen a number of deployments taking place, such as the Penguin from Wello OY being operational at EMEC and the launch of the Corpower device. In terms of components supply, an overview of suppliers for wave energy converters is presented in Table 4. Apart from a limited number of large manufacturing corporation (Bosch Rexroth and Siemens), the majority of the components supply for the wave energy industry is local to the country of origin or testing of the device.

Table 4. Detailed component supply chain for wave energy converters

Company	Fabrication	PTO & Generator	Electrical & Automation	Bearings	Marine Operations	Hydraulic Components	Certification	Coating
40South Energy			ABB					
Albatern	Zeus Engineering, Purepipe	Bosch Rexroth			Mallaig Marine	Mallaig Marine		
AW Energy			Metso				DNV GL, Lloyds Register	Hempel
Corpower		In-house				Swepart Transmission	SP	
Carnegie		Bosch Rexroth		Hutchinson				
Fred Olsen Ltd	A&P Falmouth, Supacat	Siemens			SeaRoc		DNV GL	
Wello OY	Riga Shipyard	The Switch	Veo	Schaeffler		Hydac, Seaproof Systems		

References

- Angelino, L., Dumas, P., & Pinzuti, V. (Eds.). (2017). *2016 EGEC Geothermal Market Report*. Brussels: European Geothermal Energy Council (EGEC).
- Annex, M., Robertson, D. H., Alves, L. C. R., Castro, L., Kawahara, T., & Taylor, M. (2016). *2016 Geothermal Market Outlook*. London: Bloomberg New Energy Finance (BNEF).
- Anonymous. (2016). *EU Reference Scenario 2016. Energy, transport and GHG emissions - Trends to 2050*. Luxembourg: Publications Office of the European Union. <https://doi.org/10.2833/9127>
- Anonymous. (2017). Wind Manufacturing Capacity Tool. Bloomberg New Energy Finance (BNEF).
- Antics, M., Bertani, R., & Sanner, B. (2016). Summary of EGC 2013 Country Update Reports on Geothermal Energy in Europe. In *European Geothermal Congress 2016* (p. 18). Strasbourg. Retrieved from <http://ubeg.de/Lit/EGC2016 - Keynote K1 - Country Update Reports.pdf>
- Azar, N. (2015). Hexcrete: A New Concept for Taller Wind Turbine Towers. Bloomberg New Energy Finance (BNEF). (2016). *Dataset: Organisations*. Retrieved from <https://www.bnef.com/organisations/search>
- BNEF. (2017). *New Energy Outlook 2017*.
- Bracke, R., Häder, M., Exner, S., Görke, B., Hoffmann, M., & Winkler, K. (2008). *Analyse der Wertschöpfungskette Geothermie in der Metropole Ruhr*. Bochum: Hochschule Bochum.
- Canadian Geothermal Energy Association (CanGEA). (2014). *Direct Utilization of Geothermal Energy: Suitable Applications and Opportunities for Canada*. Calgary.
- Daikin. (2014). New Daikin Altherma Ground Source Heat Pump: Tap into the earth's natural energy!
- de Vries, E. (2016). Windtech: Tower technology reaches new heights.
- Dvorak, P. (2016). Siemens intros concrete tower to reduce energy costs.
- EURObserv'ER. (2016). *Heat pumps barometer*.
- FTI-Consulting. (2016). *Global Wind Supply Chain Update 2016*.
- FTI-Consulting. (2017). Global Wind Market Update - Demand & Supply 2016, (March).
- GeoDH. (2014). *Geothermal District Heating Market Development*. Retrieved from <http://geodh.eu/wp-content/uploads/2014/12/Fact-Sheet-Market-Development-v.3-November-2014.pdf>
- Geoelec. (2014). *Towards more geothermal electricity generation in Europe*. Brussels. Retrieved from <http://www.geoelec.eu/wp-content/uploads/2014/01/GEOELEC-report-web.pdf>
- Global Wind Energy Outlook 2016*. (2016). Brussels.
- Goldstein, A. H., & Braccio, R. (2014). *2013 Market Trends Report. Geothermal Technologies Office*. U.S. Department of Energy (DoE).
- Hansen, A. D., Iov, F., Blaabjerg, F., & Hansen, L. H. (2004). Review of contemporary wind turbine concepts and their market penetration. *Wind Engineering*, 3, 247–263. <https://doi.org/10.1260/0309524041590099>
- IEA. (2015). Energy Technology Perspectives 2016: Towards Sustainable Urban Energy Systems, 1–418. https://doi.org/10.1787/energy_tech-2014-en

- IEA. (2017). *Energy Technology Perspectives 2017: Catalysing Energy Technology Transformations*, 443. https://doi.org/10.1787/energy_tech-2017-en
- Lacal Arántegui, R., & Serrano González, J. (2015). *2014 JRC wind status report energy. Technology, market and economic aspects of wind energy in Europe*. <https://doi.org/10.2790/676580>
- Lund, J., & Boyd, T. (2015). Direct Utilization of Geothermal Energy 2015 Worldwide Review. *Proceedings World Geothermal Congress*, (April), 25–29. <https://doi.org/10.1016/j.geothermics.2011.07.004>
- Magagna, D., Monfardini, R., & Uihlein, A. (2016). *JRC Ocean Energy Status Report 2016 Edition* (JRC Science for Policy Report No. JRC104799/EUR 28407 EN). Luxembourg: Publications Office of the European Union. <https://doi.org/10.2760/509876>
- Magagna, D., & Uihlein, A. (2017). *JRC Ocean Energy Database*. Petten: Joint Research Centre.
- Mitsubishi. (2014). *Ecodan Ground Source Heat Pumps*.
- Moné, C., Hand, M., Bolinger, M., Rand, J., Heimiller, D., & Ho, J. (2017). 2015 Cost of Wind Energy Review. *National Renewable Energy Laboratory*, (February), 113. <https://doi.org/NREL/TP-6A20-64281>
- Navigant Consulting. (2013). *Offshore wind market and economic analysis-Annual market assessment*, 126 pp.
- Nowak, T., & Sara Jaganjacova. (2013). *European Heat Pump Market and Statistics Report 2013*. Brussels: European Heat Pump Association (EHPA).
- Porter, M. (1985). *The Competitive Advantage: Creating and Sustaining Superior Performance*. New York: Free Press.
- Richter, A., Thompson, A., Ko, M., & Dunn, C. (2013). *Geothermal Power & Direct Use Sector Supply Chain*. Ottawa: Natural Resources Canada.
- Serrano-Gonzalez, J., & Lacal-Arántegui, R. (2016). Technological evolution of onshore wind turbines—a market-based analysis. *Wind Energy*, 19(12), 2171–2187. <https://doi.org/10.1002/we.1974>
- Shortall, R., & Uihlein, A. (2017). *JRC Geothermal Power Plant Database*. Petten: JRC.
- Sigfússon, B., & Uihlein, A. (2015). *2015 JRC Geothermal Energy Status Report* (JRC Science for Policy Report No. JRC99264/EUR 27623 EN). Luxembourg: Publications Office of the European Union. <https://doi.org/10.2790/959587>
- Sritharan, S. (2015). Wind turbine towers. Precast concrete Hexcrete may help increase renewable energy capacity with taller hub heights. *PCI Journal*, 33–38.
- Thompson, A., Davis, S., Richter, A., Ko, M., & Ryan, D. (2013). *Sector Profile. An Assessment of the Geothermal Energy Sector in Canada – Now and in the Future* (Report). Ottawa. Retrieved from http://www.cangea.ca/uploads/3/0/9/7/30973335/canmetenergy-sector-profile_update-2013.pdf
- Vázquez Hernández, C., Telsnig, T., Villalba Pradas, A., Vazquez Hernandez, C., Telsnig, T., & Villalba Pradas, A. (2017). *JRC Wind Energy Status Report 2016 Edition* (JRC Science for Policy Report No. JRC107720/EUR 28530 EN). *Joint Research Centre*. Luxembourg: Publications Office of the European Union. <https://doi.org/10.2760/332535>
- Weston, D. (2016). Nordex installs 230-metre onshore turbine. Retrieved from <http://www.windpowermonthly.com/article/1400374/nordex-installs-230-metre-onshore-turbine>

Wind Power Monthly. (2016). Big Picture: Raising expectations. Retrieved from <http://www.windpowermonthly.com/article/1403505/big-picture-raising-expectations>

Winergy. (2017). Homepage Winergy.

List of abbreviations and definitions

BOP	Balance of plant
BNEF	Bloomberg New Energy Finance
CapEX	capital expenditure
DFIG	Doubly-Fed Induction Generator
DH	District heating
EU	European Union
EESG	Electrically Excited Synchronous Generator
GSHP	Ground source heat pump
H&C	Heating & Cooling
IEA	International Energy Agency
JRC	Joint Research Centre
OEM	Original Equipment Manufacturer
ORC	Organic Rankine Cycle
PMSG	Permanent Magnet Synchronous Generator
SCIG	Squirrel Cage Induction Generator
SPV	Special purpose vehicle
WRIG	Wound-Rotor Induction Generator

List of figures

Figure 1. Wind energy supply chain with components and subcomponents 5

Figure 2. Market share (%) of the top 10 wind turbine suppliers by geographical zone from 2010 to 2016 6

Figure 3. Market share (%) of top 10 wind turbine suppliers by manufacturer from 2010 to 2016 6

Figure 4. Manufacturing facilities of European OEMs based in Europe classified according to OEM..... 8

Figure 5. Manufacturing facilities of European OEMs based in Europe classified according to component..... 9

Figure 6. Number of countries served by turbine manufacturers with at least 50 MW of capacity each12

Figure 7. Organisations in the wind energy sector: top 15 countries and EU13

Figure 8. Number of companies according to the top 15 activities in the wind energy sector worldwide14

Figure 9. Top 15 activities in the wind power energy sector, international comparison .14

Figure 10. Comparison of the current European annual manufacturing capability (GW) by wind turbine component with the current and estimated European annual deployment16

Figure 12. Breakdown of CapEx by wind turbine component18

Figure 13. Wind turbine types according to drive train configuration19

Figure 14. Evolution of the share of installed capacity by drive train configuration in onshore wind turbines by geographical zone20

Figure 15. Supply chain for geothermal energy systems: example for shallow applications23

Figure 16. Supply chain for geothermal energy systems: example for deep applications23

Figure 17. Installed capacity of European geothermal power plants in 201624

Figure 18. Market share of turbine manufacturers in Europe (left: total installed capacity; right: capacity additions after 2012)25

Figure 19. Organisations in the geothermal power energy sector according to country.26

Figure 20. Number of companies according to main activities in geothermal power worldwide.....26

Figure 21. Country shares of top 15 activities in the geothermal power energy sector .27

Figure 22. Installed capacity (MW) of GSHP in Europe28

Figure 23. Installed GSHP (1000 units) in Europe.....29

Figure 24. Installed geothermal district heating systems in Europe in 201631

Figure 25. Ocean energy supply chain accounting for component and subcomponents manufacturing.....33

Figure 26. Share of tidal and wave energy developers at global scale in 2017.....33

Figure 27. Share of organisations in the ocean energy sector classified per activity34

List of tables

Table 1. Main wind manufacturing facilities of European OEMs based in Europe10

Table 2. Overview of major European GSHP manufacturers and brands30

Table 3. Detailed component supply chain for tidal energy converters36

Table 4. Detailed component supply chain for wave energy converters38

GETTING IN TOUCH WITH THE EU

In person

All over the European Union there are hundreds of Europe Direct information centres. You can find the address of the centre nearest you at: <http://europa.eu/contact>

On the phone or by email

Europe Direct is a service that answers your questions about the European Union. You can contact this service:

- by freephone: 00 800 6 7 8 9 10 11 (certain operators may charge for these calls),
- at the following standard number: +32 22999696, or
- by electronic mail via: <http://europa.eu/contact>

FINDING INFORMATION ABOUT THE EU

Online

Information about the European Union in all the official languages of the EU is available on the Europa website at: <http://europa.eu>

EU publications

You can download or order free and priced EU publications from EU Bookshop at: <http://bookshop.europa.eu>. Multiple copies of free publications may be obtained by contacting Europe Direct or your local information centre (see <http://europa.eu/contact>).

JRC Mission

As the science and knowledge service of the European Commission, the Joint Research Centre's mission is to support EU policies with independent evidence throughout the whole policy cycle.



EU Science Hub
ec.europa.eu/jrc



@EU_ScienceHub



EU Science Hub - Joint Research Centre



Joint Research Centre



EU Science Hub

