

Nederland Maritiem Land

Tidal Energy Fish Impact:

Method development to determine the impact of
open water tidal energy converters on fish

Date: Dec 29, 2016

Project code: MIIP005

Project name: Tidal Energy Fish Impact

Project leader: Marck Smit

Organization: NIOZ

Address: Landsdiep 4

Postcode, place: 1797SZ 't Horntje

Telephone: 0222369308

Email: marck.smit@nioz.nl

Project team:

Marck Smit, NIOZ

Erwin Winter, IMARES/WMR

Peter Scheijgrond, Tocardo

Pieter Bergmeijer, TTC

Roelof Schuitema, TTC

Carly Nichols, Bluewater

Bert Visser, Topic

Martijn Thijssen, Topic

Benoit Quesson, TNO

Luca van Duren, Deltares

Ben Griffioen, IMARES/WMR

Olvin van Keeken, IMARES/WMR

Lorendz Boom, NIOZ

Janine Nauw, NIOZ

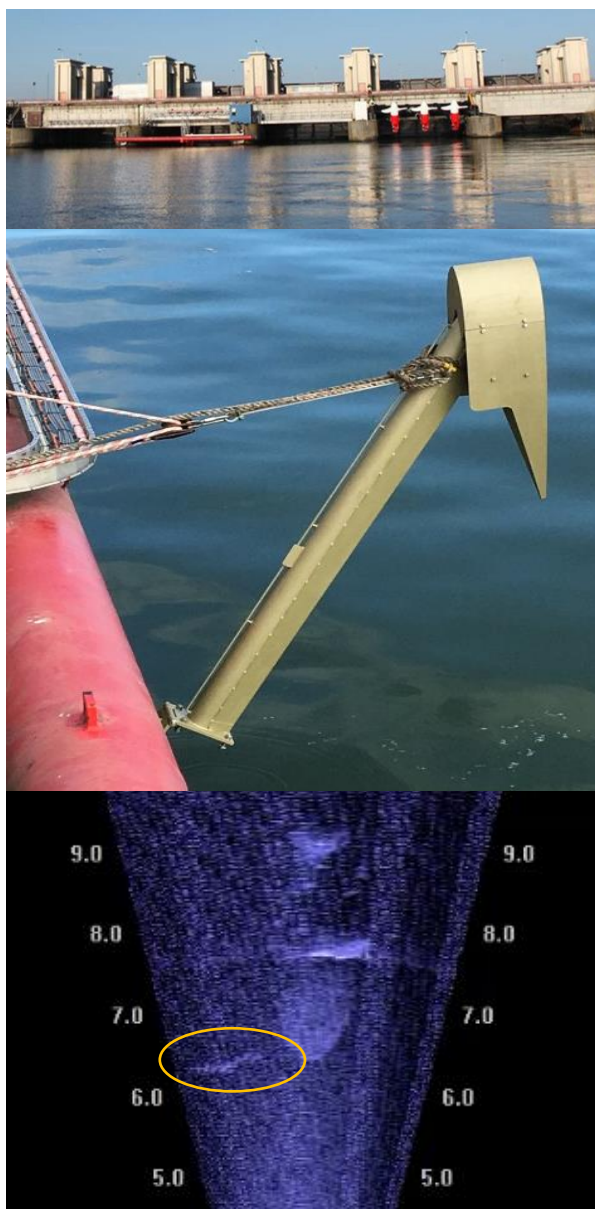

Contents

1	Background	3
2	Literature overview on impact of tidal turbines on fish and how to measure it.....	4
3	Material & Methods: test site selection and method development	7
3.1	Test site selection.....	7
3.2	DIDSON technology.....	9
4	Environmental conditions at tidal turbine test site Den Oever	10
4.1	Flow surrounding turbines in Den Oever	10
4.1.1	Flow patterns through the sluice gates at Den Oever	10
4.1.2	Flow patterns surrounding tidal turbines at the Oosterschelde storm surge barrier	11
4.2	Underwater sound measurements near the turbines in Den Oever	12
5	Development of a robust deployment method for DIDSON measurement.....	13
6	Development of automatic image analysis of DIDSON data	15
6.1	Approach for automated image analysis	15
6.2	Results of developing automated analysis of DIDSON data.....	15
7	Testing the developed methodology at Den Oever.....	18
7.1	Deployment and field testing of the housing construction for the DIDSON at Den Oever	18
7.2	Testing continuous measurement with the DIDSON at Den Oever	20
7.3	First analysis of the DIDSON measurements.....	21
8	Concluding remarks & recommendations	23
9	References	24
10	Appendix: Technical drawings of the housing design developed by NIOZ for DIDSON measurements at Den Oever.....	25

1 Background

With the need for climate change mitigation strategies, there has been more funding for the generation of electricity from renewable energy sources. One promising renewable energy source is tidal energy. Tidal energy can either be extracted using:

- i) tidal barrage plants, which utilize the potential energy of the rising and falling water heights with turbines integrated into dam-like structures:
- ii) turbines which generate electricity from the water currents in a more open environment, or
- iii) a niche application in dikes which close off areas of water in order to prevent flooding and release water back to the sea when there is excess.

Tidal energy production is foreseen to increase rapidly in the coming decades. Hydrokinetic tidal turbines in open water could potentially impact fish, e.g. by additional mortality caused by rotor blade collision. Tidal waters are important feeding areas for fish as well as passage corridors for migrating fish. To determine the impact of these structures on fish, insight in the behaviour of fish in the vicinity of the turbines (e.g. avoidance) and the collision rate and mortality of fish that enter the rotor swept area are important to determine effects on population scales.

So far, mainly model studies or laboratory experiments on collision rates of fish were carried out, but hardly no field data on the interaction between these energy converters and fish is available at present (Copping et al. 2014, Griffioen et al, 2015). The model studies on collision rates are usually based on hydrodynamic models that consider fish as 'passive objects' and do not include behaviour of fish, such as avoidance on different scales (near- and far field) because this is still unknown. However, the behaviour of fish will largely determine how many will be subjected to being hit by a rotor blade, and the stronger avoidance behaviour at different scales from far to near field is, the lower the actual collision rate will be.

The tidal turbine pilot in the Marsdiep offers a good opportunity to study behaviour of fish and collision rate in the marine field situation. However, the harsh environmental conditions are very challenging to measure this. Conventional methods such as netting constructions or visual (video) observations cannot be used due to the strong currents and the low visibility of the turbid waters in the Marsdiep. This study first focused on this location with a floating application within category ii, however due to the unit not being operational during this project's timeline, this project was shifted to another site, Den Oever, operating in a dike Afsluitdijk within the application type iii.

We propose to develop measuring methods and robust set-ups based on DIDSON technology. This is a novel high resolution sonar technique that produces video footage solely based on acoustics that allows to measure and visualise fish behaviour, e.g. individual fish (including size) or school formations, in the vicinity of the rotor blades and collision events. DIDSON has highest resolution at distances up to 10 m. Because it is an acoustic technique it can be used in turbid conditions and during both night and day, where fish avoidance behaviour and collision risk might be different. Recently, a short pilot using DIDSON with a different type of turbine (helical bladed cross-flow turbines) in Cobscook Bay (Mouth of the Bay of Fundy) showed that DIDSON is a very promising technique for this (Viehman & Zydlewski , 2015).

The goals of the proposed project are:

1. to develop a robust method and experimental set-up to determine behaviour of fish in the vicinity of tidal turbines and collision risk in the strong turbid currents of the Marsdiep based on DIDSON technology,
2. to provide a first insight and measure avoidance and collision rate of fish (and although the focus will be on fish, also if marine mammals such as harbour porpoises and seals approach the device this will be determined within the project),
3. to develop data analysis methodology since analysing large DIDSON datasets manually is very labour-intensive and will enhance the efficiency of future large scale studies using DIDSON.

2 Literature overview on impact of tidal turbines on fish and how to measure it

With the installation of turbines in the natural ocean environment, their impact on marine mammals and fish is a concern. At present, there are different ways to observe the effects of an operating turbine on marine species; although two aspects to consider are i) what happens to a fish that enters the turbine, and ii) what are the behavioural patterns of the fish around the turbine and the likelihood of it entering the turbine, e.g. the recognition of potential danger and avoidance behaviours. Depending on the goal of the study, there are various methods of looking at each of these aspects. In terms of blade strike, or what happens to a fish when it enters the turbine, computer simulations such as CFD can be used to simulate this situation, as was done in Romero-Gomez and Richmond (2014); or tests where fish are manually placed before a turbine (either in a laboratory or flume, or in-situ in the ocean environment with nets) and caught afterwards could be used to determine the effects and mortality rate.

The most important findings and considerations in relation to fish behaviour, collision risk and methodologies used are listed below for different literature sources:

ABP Marine Environmental Research (2010) and Hammar et al. (2013):

- Fish movements recorded with and without rotor in place
- No fish collided with rotor
- Deterrent effect of fish increased with current speed.
- Heavily reduced passage of fish (avoidance) – only a few passed through
- Vertical axis, triple helix turbine
- Stereo-video system
 - 2 synchronized, converged cameras
 - Can obtain lengths and distances

EPRI (2014), Amaral et al (2015) and Broadhurst et al. (2014):

- Abundance was significantly associated with velocity rate
- OpenHydro, open turbine, 6 m diameter
- Video Triplex 8 Channel DVR, linked to a Submertec Camera System mounted to the outside of the OpenHydro platform device.
- ADCP measured the currents speed
- Mounted approx. 2 m from turbine; could record across entire 6 m diameter
- Five, random photographic still frames were extracted from the first 2 minutes of every hour of footage.

Copping et al. (2014):

- Marine energy devices may act as an attractant to animals and birds, may act as fish aggregating devices, or may deter marine animals which could prevent them from accessing important areas for feeding, breeding, etc. (See Sec 2.1)
- Marine Current Turbine's SeaGen project, monitoring methods:
 - Aerial and shore-based surveys of marine mammals and birds by observers
 - Aerial, satellite, and boat surveys of signals from tags on harbour and grey seals
 - Passive acoustic monitoring of clicks made by harbour porpoises using WPODs
 - Underwater noise measurements from a device mounted on the turbine foundation and from boat surveys
- Ocean Renewable Power Company – barge-mounted tidal turbine
 - Observers
 - Two acoustic DIDSON cameras before and after the turbine

- Results: higher proportion of fish when turbine not operating; fish commonly entered the turbine; mortality was not determined yet no dead or dying fish found behind the turbine.
- Hydro Green Energy – barge-mounted tidal turbine
 - Fish tagged and put directly in front of the turbine then retrieved after they passed through the turbine.
 - Survival for small and large fish was greater than 99% after 48 hours.
- OpenHydro, open-centre turbine
 - Video footage and shore-based observers
 - No fish strike mortality or fish swimming through the turbine was observed
 -
- Verdant Power
 - 24 acoustic cameras (splitbeam transducers, mobile SBT transect surveys, DIDSON systems, and vessel and shore-based observations
 - Resident and migratory fish avoided the area where the turbines were located, preferring slower moving waters near shore
 - As tidal speed increased, fish appeared to react to the current speed increase more than the turbines since they left the area.
- Laboratory and flume study – Electrical Power Research Institute
 - Only a small number of fish passed through the turbine blades; most fish swam upstream and/or were swept around the turbine
 - Survival rates for those passing through the turbine were greater than 98%
- Numerical modelling of fish blade strike has been done in the past

Melvin & Cochrane (2015):

- Paper examines operational capabilities of two high-frequency multibeam sonars, in near shore high-flow shallow coastal waters
- “Tidally induced currents suitable for energy extraction create physical limitations and background turbulence that impede the use of traditional sampling methods (mechanical and acoustic) and deployment approaches.
- “Acoustics is one of the technologies well suited to the task, but it too has limitations. Observations may be restricted to a small portion of the water column during specific phases of the tide, and special deployment approaches may be required.”

Romero-Gomez & Richmond (2014a):

- Unsteady CFD simulations of turbine flow and DEM of particle motion to estimate the frequency and severity with a horizontal axis tidal turbine.
- Metrics: Strike frequency and survival rate.

Romero-Gomez & Richmond (2014b):

- Simulations performed using two modelling approaches
- Looked at the occurrence, frequency, and intensity of blade-strike of fish on an axial-flow marine hydrokinetic turbine.
- Survival rates were greater than 96% in all scenarios; fish passing through blades.

Viehman & Zydlewski (2014):

- Two DIDSON acoustic cameras were used to observe fish interactions with a commercial scale turbine
- Mounted upstream and downstream
- Probability of fish entering the turbine decreased by over 35% from when it was not operating.

- Looked at effects of turbine motion, diel conditions (day or night), and fish size on individual behaviours, and compared individual fish to schools of fish.
- Fish swimming at an angle to the current were harder to visualize and were unlikely to be detected.
- The rotation of the turbine caused a slight blurring around the blade edges, so everything within approx. 5 cm of the blades was not discernible.
- Resolution was generally too low to determine if a fish was facing into the current or not, although its net movement was discernible.
 - Largest shortcoming
 - Fish with lengths under 10 cm were difficult to measure with certainty (resulting in broad group sizes)
- “Given the limits of our viewing window, behavioural responses at that spatial scale could not have been detected. Since more fish and schools observed were above or below the turbine when they entered the upstream view, they may have already responded to the turbine or platform.” Viewing window made it difficult to follow fish from upstream to downstream and fish may have been counted twice (although unlikely).
- Article cited: Fish have the ability to detect moving objects via senses other than vision (Blaxter and Batter, 1985).
- Useful tool for monitoring fish interactions, especially at night (video camera would not have been useful without artificial light)
- DIDSON could not provide information on direct blade strike or the condition of the fish exiting the turbine.
- Processing of DIDSON footage is extremely time consuming. Automating fish detection would drastically reduce processing time.
- DIDSON can only sample short ranges, up to 10 m.

To observe the behavioural patterns, the manual introduction of fish before the turbine can also provide information on this, depending on the set-up. However to better observe the species in their natural setting, cameras or acoustic equipment (such as DIDSON) can be used. Cameras are quite useful, however they may not be suitable in high-turbidity waters or observing species at night. Acoustic equipment, such as DIDSON, is more appropriate for high-turbidity waters and night observations, yet the images are not as clear and the observational window is not as wide as video at this time. Processing of DIDSON footage is also very time consuming, yet if the process was automated, this could greatly reduce the processing time (Viehman & Zydlewski 2014). Other methods for observations of behavioural patterns of larger mammals include shore or in-situ (boat or on the support structure) observers, as was done in the Strangford Lough in Northern Ireland with the SeaGen turbine. Aerial, satellite, and boat surveys of tagged animals with signals were also used in that project, along with passive acoustic monitoring of clicks made by harbour porpoises (Copping et al. 2014).

3 Material & Methods: test site selection and method development

3.1 Test site selection

Initially the Bluewater/Tocado tidal turbine pilot in the Marsdiep was selected as the test site for this project because it offers a good opportunity to study behaviour of fish and collision rate in the marine field situation (figure 3.1 and 3.2).

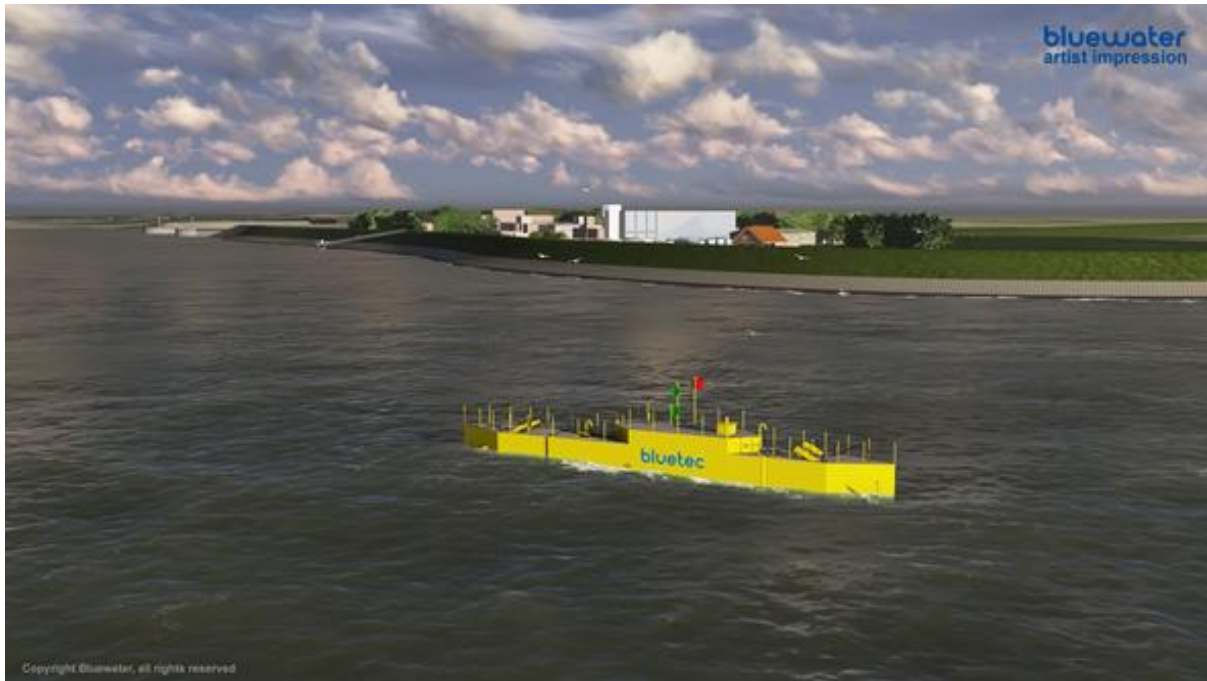

Figure 3.1. Artist impression of the Bluetec test site in Marsdiep.

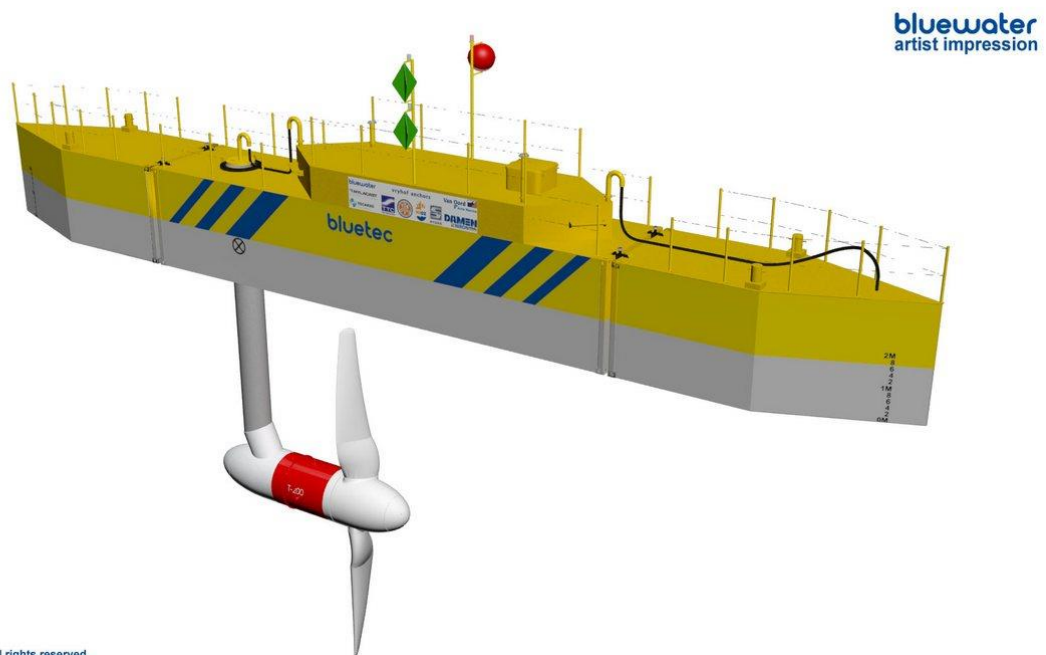

Figure 3.2. Impression of the Bluetec Tidal Turbine test construction in the Marsdiep with Tocardo turbine.

However, due to a break in the power cable and subsequently non-operating conditions of the tidal turbine at the test site of the Marsdiep during the course of this project, a different test site, the tidal turbine test location at Den Oever, was proposed and accepted for this project. Here also harsh environmental conditions are present and with water velocities of 3-4 m/s even higher than in the Marsdiep, which are very challenging to measure fish behaviour with measuring devices. Conventional methods such as netting constructions or visual (video) observations cannot be used due to these strong currents and the low visibility of the turbid water flowing from lake IJsselmeer to the Wadden Sea at Den Oever. The tidal turbine test site of Den Oever consists of one turbine that is placed in sluice 2, and 3 turbines that are placed in sluice 4 (figure 3.3 and 3.4).



Figure 3.3: Aerial overview of the test site at Den Oever. The first tidal turbines in sluice 2 (from left to right) and the setting of 3 turbines in sluice 4. For this project the turbine in sluice 2 was used.

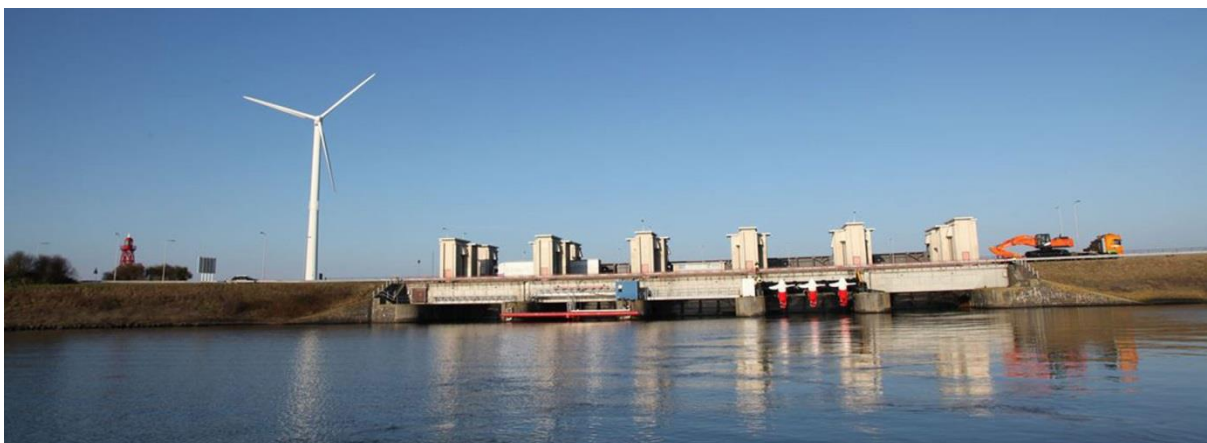

Figure 3.4: Front view of the tidal turbine test location at Den Oever. The first tidal turbines in sluice 2 (from left to right) and the setting of 3 turbines in sluice 4. For this project the T1 turbine in sluice 2 was used (Tocado).

The beam construction already present in sluice 2 with the single turbine was very well suited to mount an additional fixed construction housing the DIDSON device to be developed within this project (figure 3.5) and it was therefore decided to develop and test the DIDSON measurement technology with the single Tocardo turbine operating in sluice 2 of Den Oever.



Figure 3.5. The beam construction holding the Tocardo T1 tidal turbine in sluice 2 of Den Oever that was used to serve as a base for developing a robust housing construction to perform DIDSON measurements here.

3.2 DIDSON technology

The high resolution DIDSON sonar (<http://www.soundmetrics.com/>) uses acoustic lens technology which forms acoustic images with greater detail than found in conventional sonars. DIDSON allows observing fish (behaviour) in turbid water during both night and day (since it is an acoustic technique producing near video images).

The DIDSON high resolution acoustic camera has the following specifications:

- Operates at 1.1 – 1.8 MHz
- Typical range 10 m (at 1.8 MHz) or 30 m (at 1.1 MHz)
- 48-96 beams; 0.4° H by 14° V
- Power consumption: 25 W

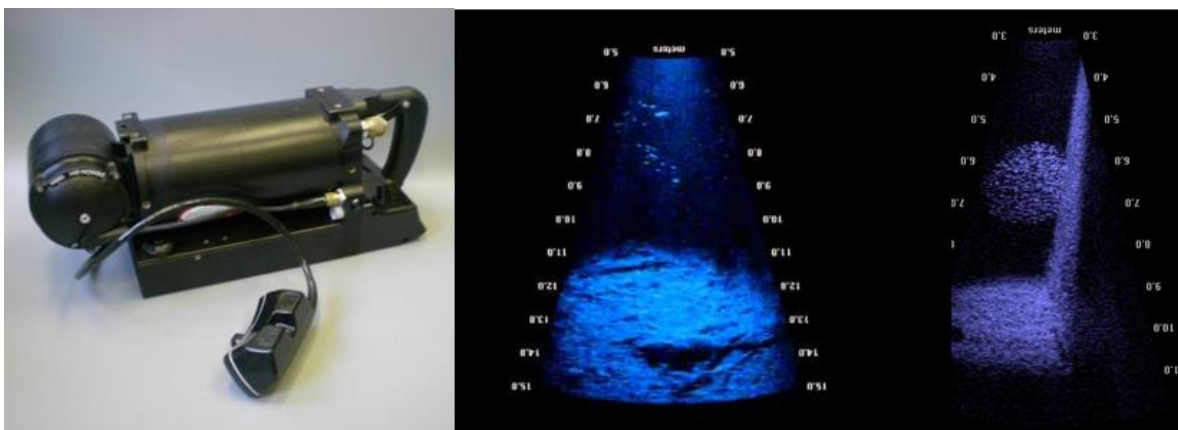

Figure 3.6. DIDSON acoustic camera (left panel) and two examples of image output; underwater bottom structure with some fish (middle panel) and school of fish in front of a trash rack at a large pumping station (left)

Best images with greater detail are made at 1.8 MHz and this setting was aimed at to be used in the field testing experiments performed within this project. There is standard software available to view and analyse DIDSON measurements and output.

4 Environmental conditions at tidal turbine test site Den Oever

The behaviour of fish approaching a tidal turbine is very much dependent on environmental factors, where obviously the strong flow conditions play a major role. But also other potential cues triggering fish behaviour such as underwater sound, light conditions and turbidity.

4.1 Flow surrounding turbines in Den Oever

In order to interpret data from the DIDSON camera or other observational techniques with regard of fish behaviour in response to the presence of tidal turbines, detailed insight is required on the near-field fluid dynamics surrounding the turbines. There will be flow velocity thresholds regarding the escape distance, in other words, beyond certain velocity limits fish entrained in the flow will not be able to escape this entrainment. This is determined by the swimming abilities and particularly the escape abilities of the fish. Also, fish are able to detect fluid dynamic distortion. The levels of shear and vorticity can be perceived by mechanoreceptive hairs in the lateral line system of fish, giving them early warning of impending danger and allowing them to elicit escape responses before escape becomes impossible.

4.1.1 Flow patterns through the sluice gates at Den Oever

At the moment there is no accurate description of the flow around the tidal turbines where the tests of the current project have been carried out. To give some idea about flow velocities and the flow deformation that can be expected we have collected information from the discharge sluices at Den Oever, modelled by the Delft3D package. This gives information about the non-impeded flow, i.e. without the presence of tidal turbines. Delft3D is not the most ideal system to model flow within a relatively complex 3D structure. However, the overall flow pattern is reproduced with sufficient accuracy to get an impression of the peak velocities, the thickness of the boundary layer and flow near the bed.

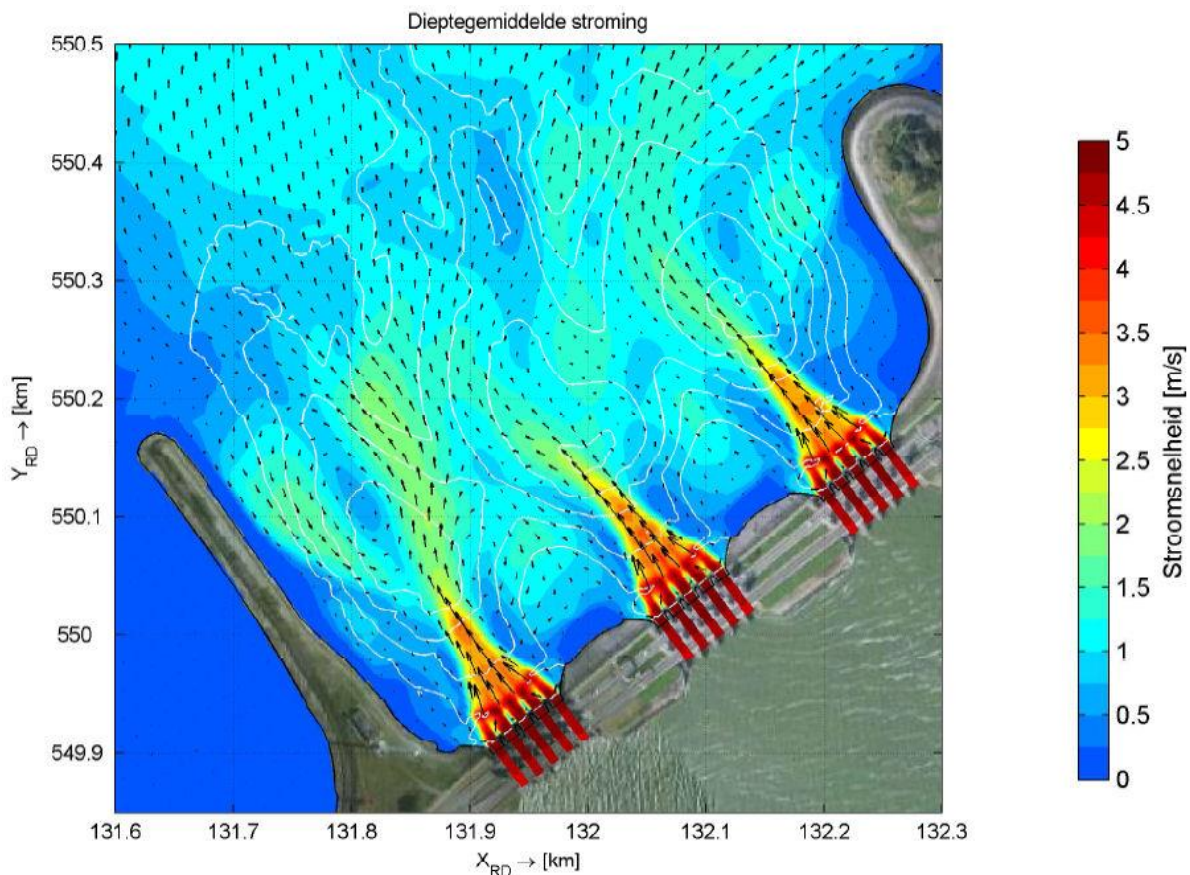

Figure 4.1: Simulated flow through the sluice gates at Den Oever with all sluice gates open. Figure taken from Reijmerink and Bijlsma, 2016).

The flow in the sluices is governed by the difference in water level between the IJsselmeer and the Wadden Sea as well as the discharge regime, i.e. whether all sluices are open or if some are closed. In Reijmerink and Bijlsma (2016) a hydrodynamic analysis was made of various maximum discharge events with different sluice configurations. Maximal flow velocities within the tubes reached about 5 m/s. At the seaward side the outflow (depending on the discharge configuration) the clearly visible ‘jets’ from the sluice gates decayed to a more or less uniform pattern over a distance of about 400metres. Also turbulence intensities decayed to background levels over this distance. When all three groups of 5 discharge tubes each are in operation, the return flow lateral to the discharge jets is limited (figure 4.1). Return flows lateral to the jets (i.e. in the direction of the sluices) are most pronounced in the case of the outer two groups in operation and the middle set closed (figure 4.2). In this configuration the extent of distinct jets with areas of lateral shear persist over a much longer distance (beyond the scope of the domain). This is also true for turbulence intensities.

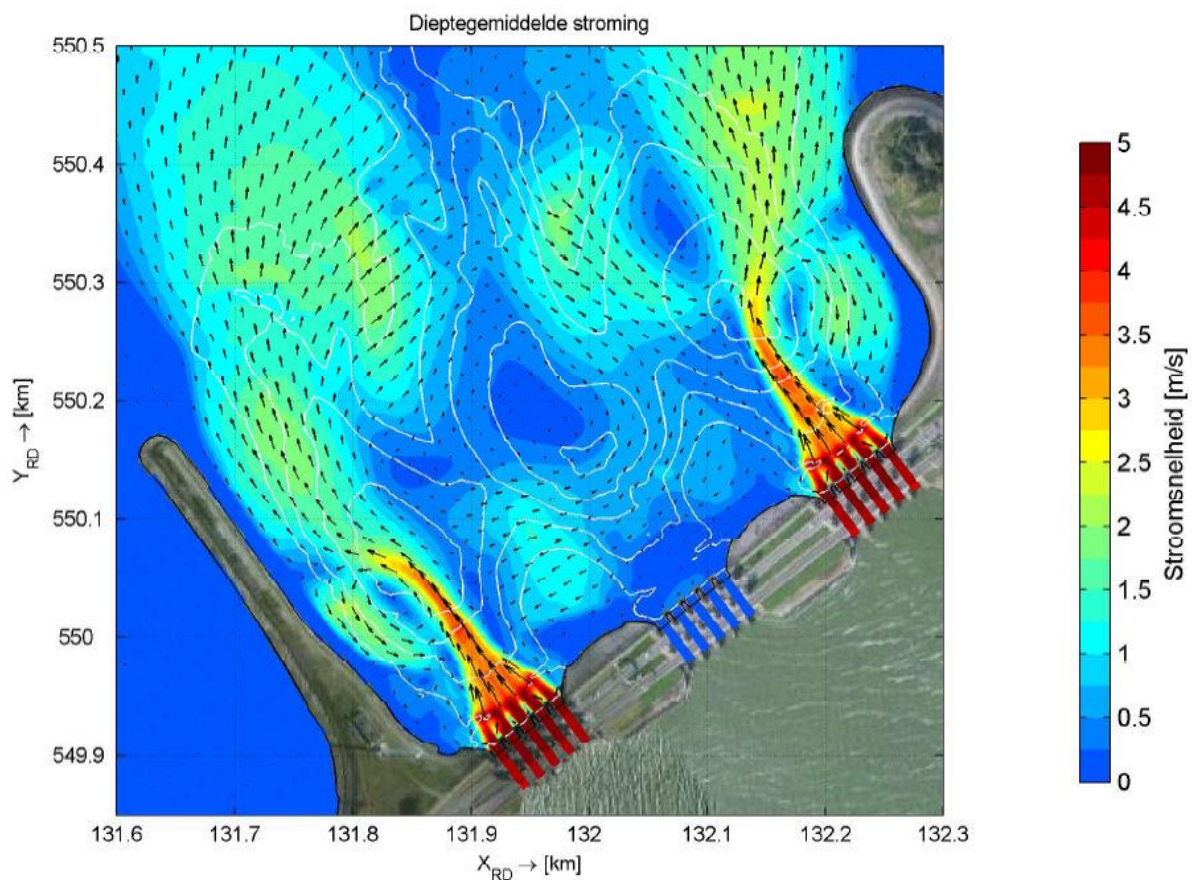

Figure 4.2: Simulation of flow through the sluice gates where the middle set of sluices is closed. Figure taken from Reijmerink and Bijlsma 2016

4.1.2 Flow patterns surrounding tidal turbines at the Oosterschelde storm surge barrier

There is also preliminary model information of flow around tidal turbines similar in design as the ones in the Afsluitdijk, but in this case modelled in one of the pillars of the Oosterschelde. These model data are obtained with the computational fluid dynamics (CFD) package Star-CCM+. CFD resolving the full Navier-Stokes equations of fluid motion in 3D and is the most suitable model approach to investigate flow surrounding tidal turbines. The images provide insight into the flow phenomena surrounding the turbine. We have to stress that these model results are not yet validated by suitable near-field measurements. Apart from the fact that flow details will differ per location, the model results themselves have to be treated with some caution, especially with respect to quantitative detail. For future detailed analysis and proper interpretation of the behavioural data from the DIDSON camera, a validated model of the actual test site is required. However, the current results are consistent with general hydrodynamic theory and the general phenomena that are visible in the model results will be valid.

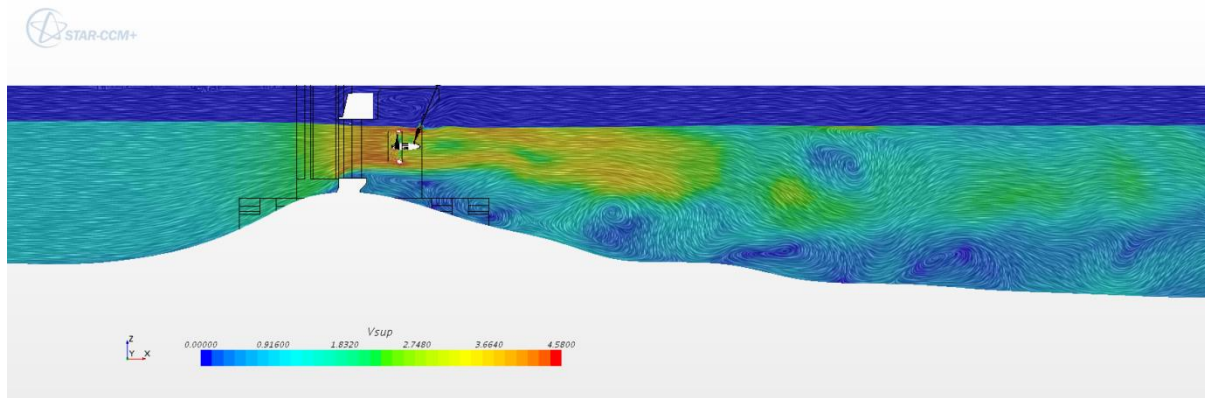

Figure 4.3: Lateral view of the modelled turbines in the Eastern Scheldt storm surge barrier.

First a CFD simulation has been carried out on a single T1 Tocardo turbine hanging below the surface in free-flowing water, with a uniform velocity of 4 m/s (Tralli *et al.*, 2015). Subsequently a model simulation has been carried out of a set of 5 tidal turbines in the Oosterschelde, located in gate #08 of the storm surge barriers. In normal conditions the ebb and flood flow through the barrier is characterized by a maximum head loss of about 1 m with maximum velocities of 4 m/s and higher. The outflow of the barrier is extremely turbulent. The turbines are situated on the Oosterschelde side of the barrier. The CFD flow computations have been carried out on a flood flow with a velocity of 4 m/s between the pillars of the barrier, immediately upstream of the turbines (figure 4.3). Although the configuration and the ambient flow will differ between turbines in Den Oever and turbines in the Oosterschelde, some very general rules will apply in most cases. Flow deformation starts at a distance of roughly five times the rotor diameter (very difficult to discern in the plot). Peak velocities exceeding 4.5 m/s can be found immediately adjacent to the rotor tips. This is an area with very strong velocity gradients. Due to the sill of the barrier an area of low flow velocities near the bed immediately behind the sill is present. Apart from the obvious risk to fish entrained in flow through the barrier, at risk of passing through the rotating blades, future research might also focus on the risk to fish that are sheltering in this relatively calm section below the turbines that may swim upwards. The turbulence intensity in this section is still relatively high and the gradients around the turbine very steep. I.e. there might be very little distance between a hydromechanical warning signal that can be perceived by fish and the tip of rotating blades.

4.2 Underwater sound measurements near the turbines in Den Oever

In the frame of this project, TNO investigated the possibility to measure the underwater radiated noise from a tidal turbine under different representative tidal streaming conditions (maximum streaming in and out, and still condition). Preparatory work have been conducted in the form of brainstorming and information gathering within TNO in order to define a measurement setup:

- It is known that fishes are sensitive to particle motion, the possibility to acquire/lease a particle velocity sensor is being investigated for DMEC (work in progress)
- A particular point of attention for the measurement setup is the reduction of the flow noise associated with tidal streams in order to obtain a workable signal-to-noise ratio. Different options will be considered: use of an array of hydrophones and/or a local shielding of the measurement hydrophone(s) (work in progress).
- The actual measurements have been postponed and will happen in the frame of the DMEC project for two main reasons:
- More time to define and prepare the measurements (types of sensors, number, exact positions, etc.).
- Possibility to correlate the measured data with additional available sensors (ADCPs and DIDSON data for instance) during the DMEC project which could prove very valuable in order to 1/ characterize the local flow conditions and 2/ identify the specific cues used by fishes to detect the turbine.

5 Development of a robust deployment method for DIDSON measurement

The DIDSON is an expensive measuring device and the conditions that tidal turbine operate in are very challenging with high water currents. Therefore a robust housing is needed that can withstand high water currents (up to 4.5 m/s at Den Oever), collisions with floating debris and preferably operate with no or minimal resonance or vibrations to optimise image quality taken by the DIDSON. For this project a housing was developed that was assessed to be robust against the prevailing conditions at Den Oever.

The design aimed at:

- Strong construction and materials that can withstand currents up to 4.5 m/s and eventual collisions with debris present in the discharge flow.
- Vibration free mounting on the beam construction already existing in sluice 2 at Den Oever supporting the tidal turbine.
- Streamlined housing around the DIDSON to minimise drag turbulence created by the measuring device which could potentially lower the quality of the DIDSON footage shot during discharge events
- Mounting the DIDSON at a low angle facing the turbine just below the expected turbulence wake created by the housing itself.
- Mounting the DIDSON at a distance to the turbine that allows high resolution frequency (1.8 MHz) with operates up to 10m distance, and also maximizes the section of the turbine that can be viewed by the DIDSON beam.
- Enable to lift the DIDSON housing free from the water and fixate it in an uplift position above the water.

This resulted in the design as given in figure 5.1 and 5.2. The housing was constructed in the marine technology workshop of NIOZ during August-September 2016. The angle at which the DIDSON was positioned within the housing enables to view the top part of the area swept by the turbine blades (figure 5.1).

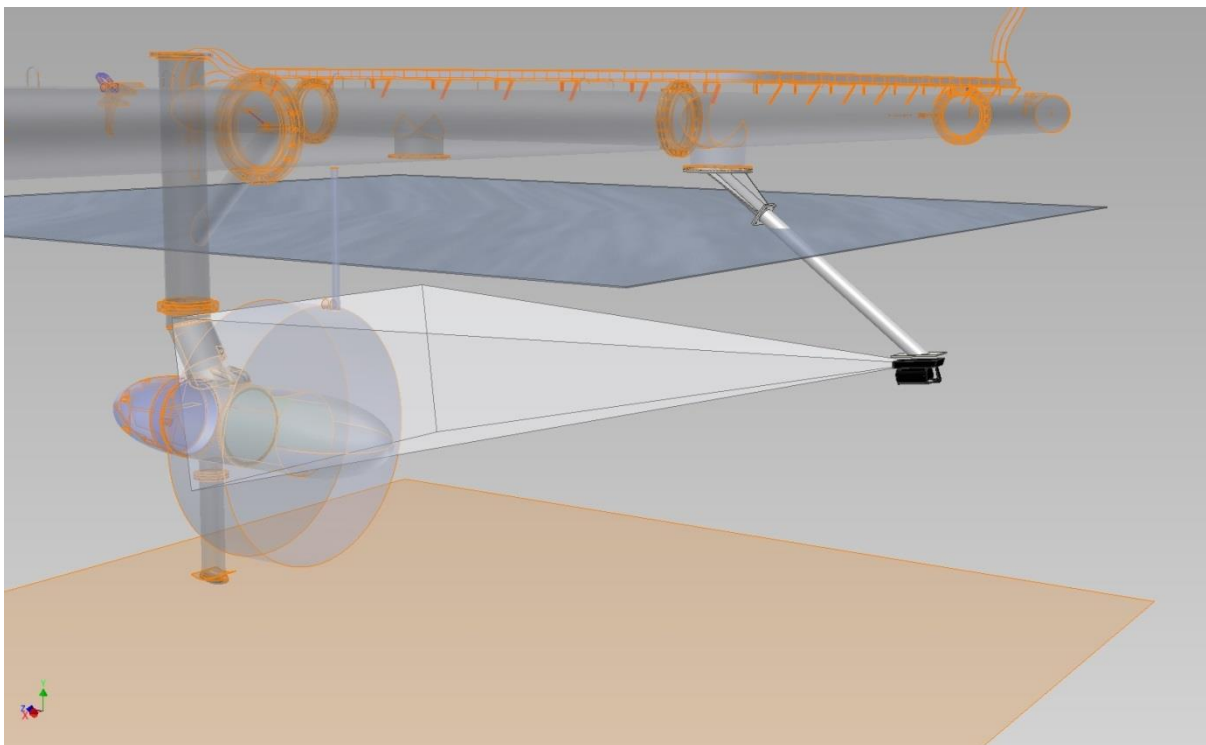

Figure 5.1. Schematic drawing of the set-up and design of the mounting and housing for the DIDSON camera and its position towards the Tocardo T1 tidal turbine. Distance from the DIDSON to the turbine blades is ~8m.

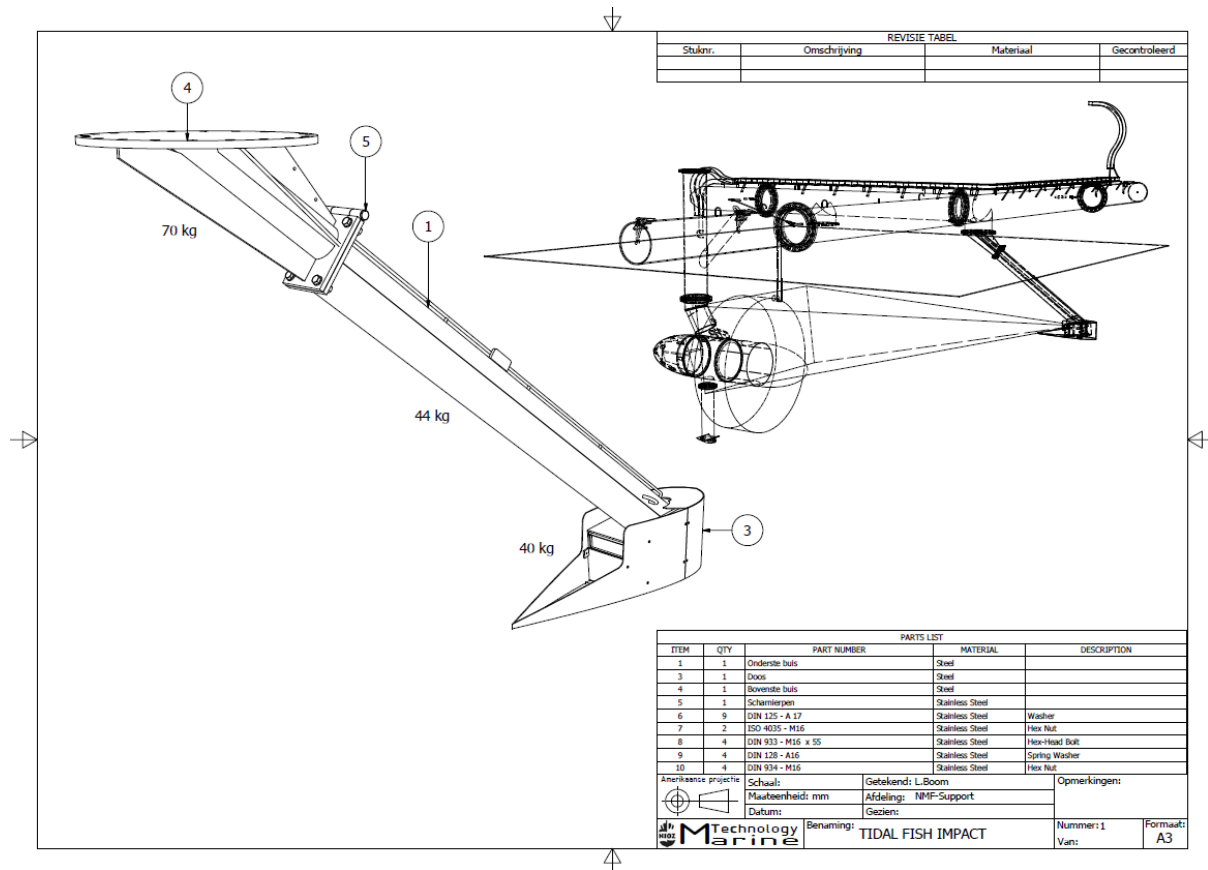

Figure 5.2. Technical drawing of the housing design for the DIDSON measurements at Den Oever (see Appendix for further detail drawings)

6 Development of automatic image analysis of DIDSON data

To study the behaviour of fish with the use of an ultrasonic camera (DIDSON) and use image analysis techniques to analyse the footage automatically, in this section we discuss the approach of the image analysis techniques, the results and recommendations for this.

6.1 Approach for automated image analysis

The image analysis techniques use a method of finding moving objects for a minimum time interval and counting their size. The goal of using a minimum time interval and counting the size of individual objects is to reduce the chance of finding false positives.

In detail, the used algorithm consists of the following steps.

1. Background subtraction.
2. Foreground smoothing.
3. Motion detection.
4. Masking region of interest.
5. Smoothing & noise reduction techniques.
6. Image segmentation.
7. Labeling the segmented image.

The algorithms have been prototyped in the following way.

- DIDSON software processes steps 1-3.
- Custom software processes steps 4-7.
- Two prototypes for the custom software.
 - Matlab with the Image Processing Toolbox.
 - Python with SciPy (open source).

6.2 Results of developing automated analysis of DIDSON data

Figure 6.1 shows a shot of captured footage and figure 6.2 shows a shot of analyzed footage. The footage is analysed in the region 8m - 17m (masking). Up to 8m, the image shows noise due to disturbances and above 17m the image shows an echo.

The algorithm has the following controlling parameters

- blobMinPixelSize = 10.
Find objects of specified minimum size (in pixels).
- blobSizeThreshold = 100
Fish are detected if total object size is greater than this value (in pixels).
- blobNumberOfFrames = 1.0
Objects should at least be visible for specified time interval (in seconds).
blob size should be at least specified number of seconds visible
- blobMinVideoGap = 1.0
Time interval after detecting the fish (in seconds).

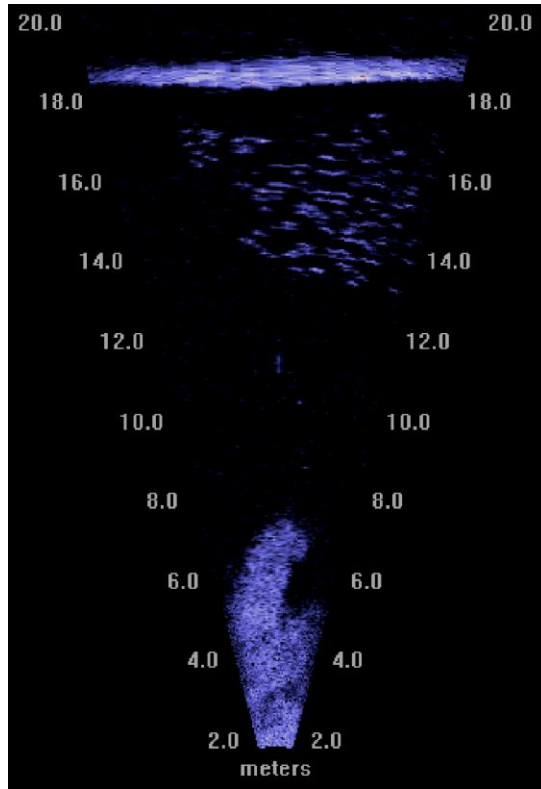

Figure 6.1 – Captured Footage

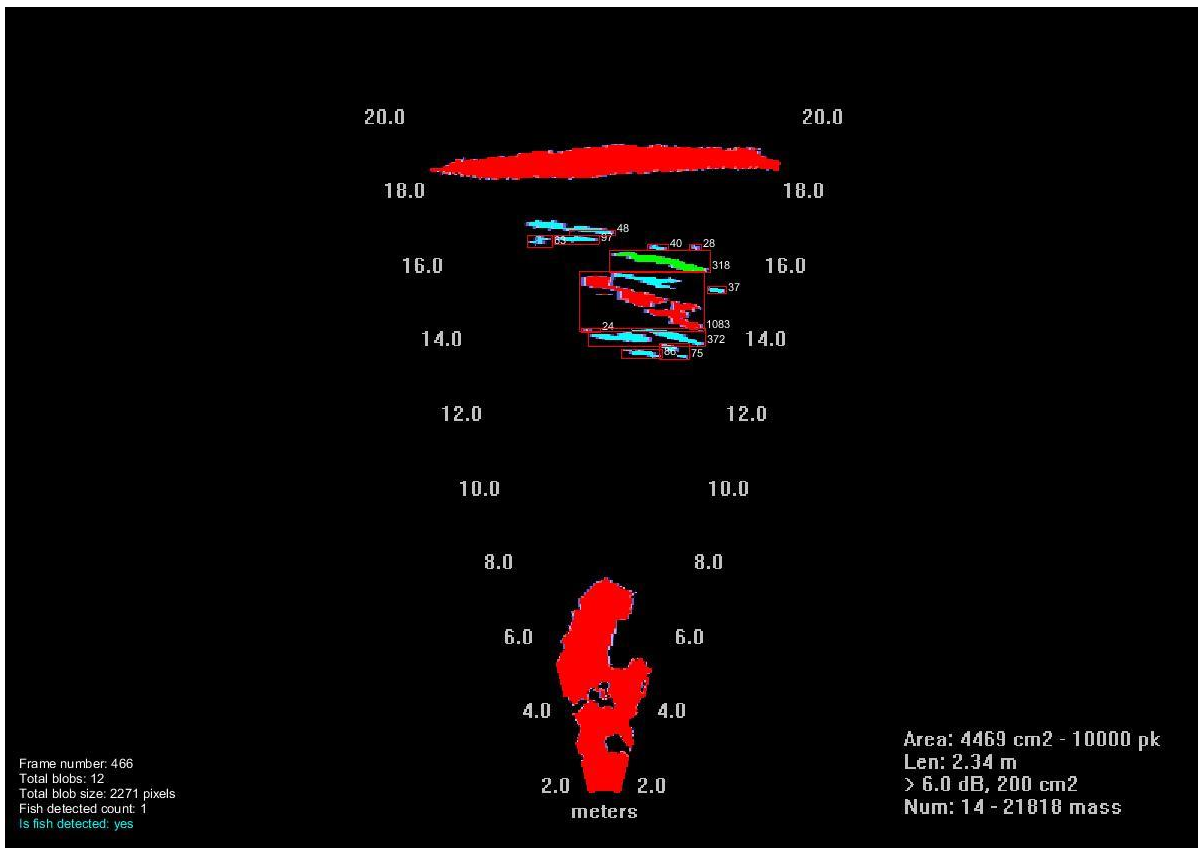

Figure 6.2 – Analysed Footage

The reference footage as shown in the previous figures can be analyzed automatically. However, the footage captured at Den Oever has too much interference making automatic analysis impossible with the current footage.

For a successive project, we have the following recommendations.

- **Reduce interference in captures.** The amount of interference causes so much noise that filtering techniques filtering out the interference, also filters out all small fish. This only leaves detection of large fish.
- **Increase frame rate.** Objects should be visible for a minimum duration or they are considered noise. The current frame rate is quite low: 10 frames per second. When fish move very fast, the algorithm ignores these.
- **Follow specific fish movements.** Currently all motion is monitored and detected. It is possible to reduce false positives if you consider fish moving in from the bottom (8m) and swimming to the top (17m).

7 Testing the developed methodology at Den Oever

7.1 Deployment and field testing of the housing construction for the DIDSON at Den Oever

On Monday 19 September 2016, the housing construction developed within this project was installed and tested in sluice 2 at Den Oever. Because of ongoing sluice maintenance works at the sluices at Den Oever, Rijkswaterstaat did not use the Den Oever sluice complex to discharge water from lake IJsselmeer during September 2016, but instead used the Kornwerderzand sluice complex. As a result no testing under flow conditions was possible. No problems occurred with the mounting and installation of the housing structure (see figure 7.1-7.4 for a photo impression of the construction and work carried out).



Figure 7.1: The housing was installed with a Zodiac at the Den Oever site



Figure 7.2: Installing the DIDSON in the housing (left) and fixing the DIDSON cable to the beam structure in sluice 2.

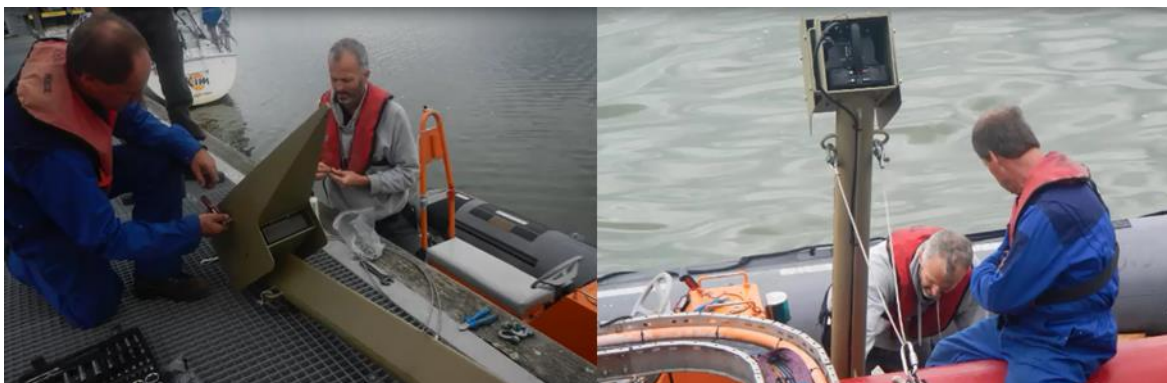

Figure 7.3. Mounting the streamlined waterbody housing the DIDSON and mounting the pole to the beam structure.



Figure 7.4. Mounting the lift cable/ropes to the streamlined waterbody housing the DIDSON (left) so that the housing device can be fixated in a uplift position above the water (right).

The functioning of the DIDSON was tested under non flowing conditions during 19 September 2016. The DIDSON functioned well, except that when the power generating convertor of the tidal turbine was switched on, interference lines appeared in the DIDSON images (see figure 7.5).

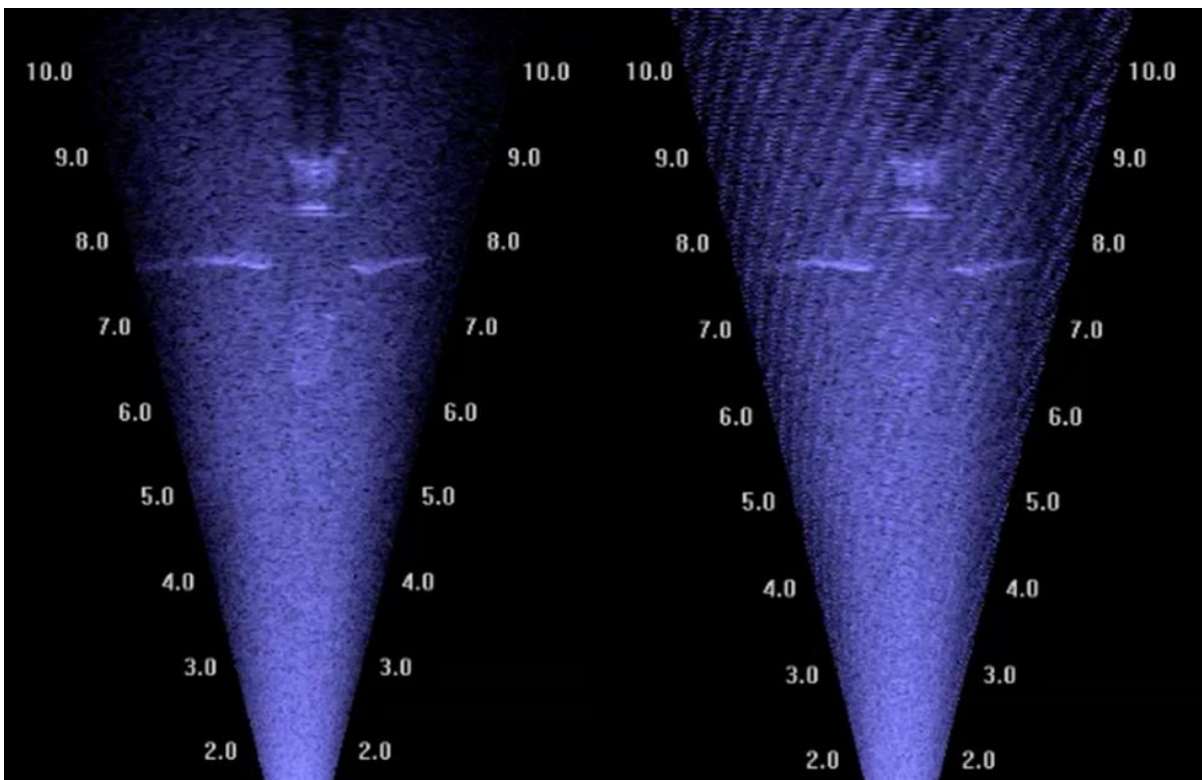

Figure 7.5. DIDSON images of the tidal turbine with turbine power generation mode off (left) and on, where interference lines were visible (right).

Despite trying different changes in the power supply (at the cabin where the power generator was housed versus from the cabin of the other tidal turbines in sluice 4 which were switched off), in changing the pathway of the DIDSON cable along the beam structure and more away from the power generation cables and placing the DIDSON laptop outside the cabin did not provide a solution for the interference

lines. The image quality of the DIDSON was good enough, despite these interference lines, to observe the turbine with its rotating blades (they periodically make a few turns also in non-flowing conditions) and the presence of fish, as indicated by the clear detection of a school of small fish (< 10 cm) that swam through the DIDSON beam in the course of the 19 September field test (figure 7.6).

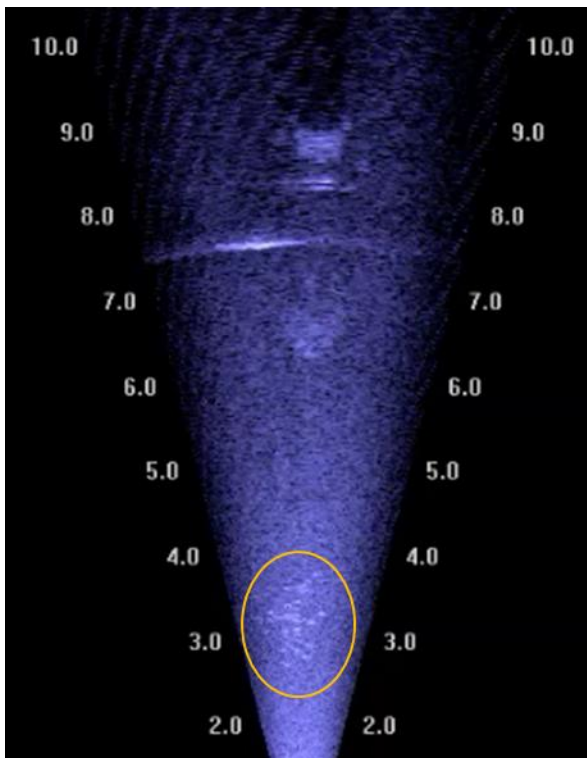

Figure 7.6. School of small fish (< 10 cm) passing in front of DIDSON

7.2 Testing continuous measurement with the DIDSON at Den Oever

As of 16 October 2016, Rijkswaterstaat resumed discharging via the Den Oever Complex. On 19 October 2016, the measuring construction with the DIDSON was reinstalled and positioned in the water column. Additional tests were performed to get rid of the interference: i.e. grounding the DIDSON and housing to the beam structure, measuring from within the housing construction versus the DIDSON in the water column without the housing and using a separate aggregate/generator versus network power supply, but none of these actions resulted in losing the interference. Therefore it was decided to carry on to test for long-term measurements (continuous measurement). The 30 m DIDSON cable was fixated and connected to a pc with an external 3 terabyte hard disk placed in the cabin directly next to sluice 2 (figure 7.7).

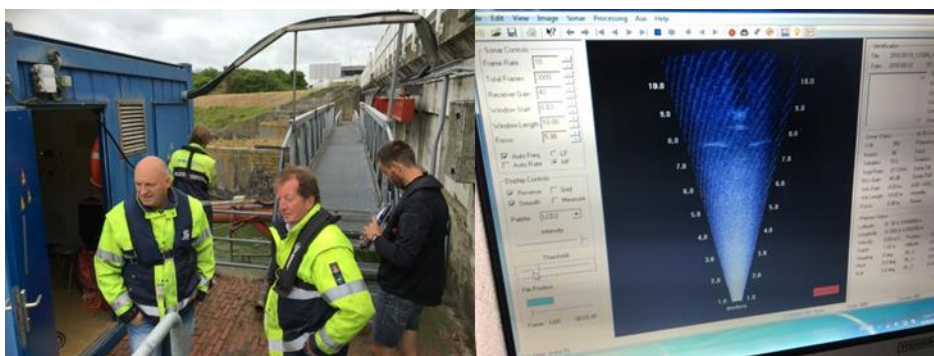

Figure 7.7. For the testing of long-term measurement with DIDSON at Den Oever a pc with external hard disk was placed in the cabin directly situated near the test turbine in sluice 2

The long-term/continuous measurements lasted from 19 October to 3 November 2016, i.e. 15 days of continuous monitoring. The system has been functioning well and recording continuously throughout these 15 days resulting in good footage. In total 250 MB of footage was recorded, equalling 366 hours and 4,000 files.

7.3 First analysis of the DIDSON measurements

Within the scope of this project it was impossible to extensively analyse the large dataset acquired during 19 October – 3 November 2016. Due to the interference there was no automated selection of potential 'fish events' possible. We therefore sampled a few sections of in total several hours and manually screened them. During the peak a discharge event occasionally swirls of turbulence were visible, mainly in the first 5 m of the DIDSON images, but most of the time periods sampled had good quality footage. Also in full power operation of the tidal turbine still interference was present. Within the small time periods that were sampled we identified two events in which eel was seen, one during the last phase of a discharge event when currents were lower than at maximum flow, and one during no flow condition.

The eel that approached the turning turbine blades came passively drifting sideways with the flow towards the turbine and at close proximity from the turbine blade it swam away and escaped passing underneath the bulb to the left side at an angle slightly against the current (figures 7.8 and 7.9).

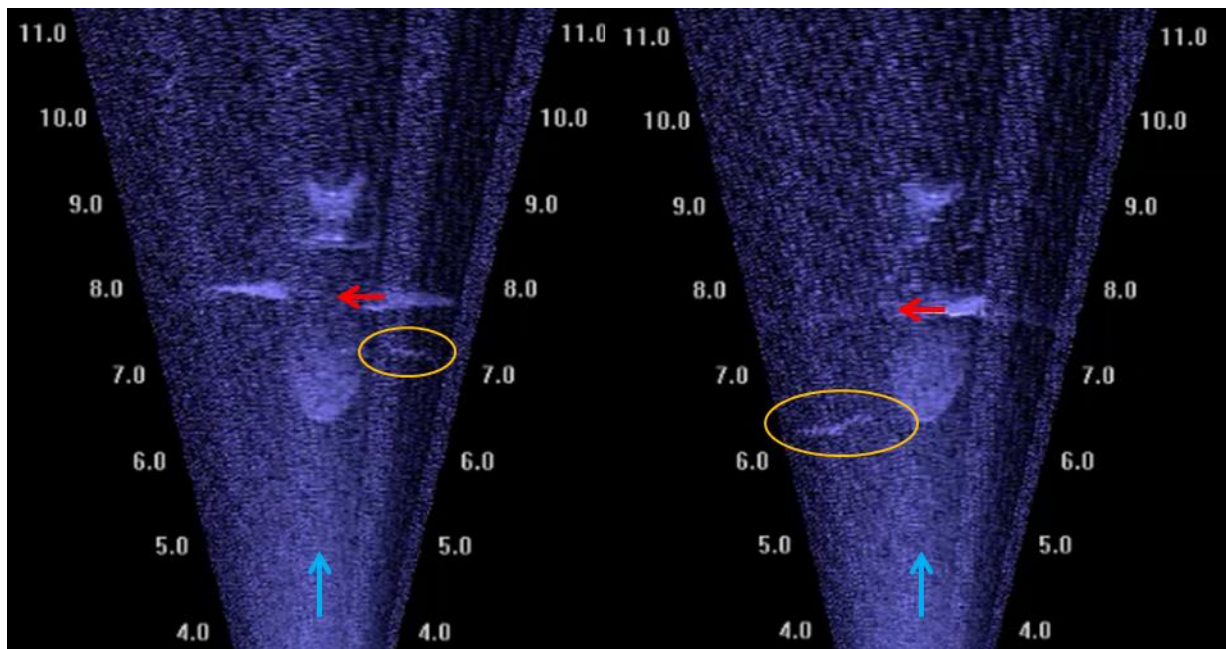

Figure 7.8. An eel approaching the turbine drifting sideways towards the turbine blade (left panel) and after slightly turning and swimming away to the left slightly diagonal into the current. The blue arrow indicate water flow direction, the red arrows indicate the direction that the turbine blades are turning to.

This behaviour is very similar to what has been observed with the DIDSON in front of a large pumping station in the canal Noordzeekanaal, where eels mostly drifted sideways or even curled up when approaching the trash rack before swimming away in a diagonal direction towards the bottom against the current and away from the trash rack (van Keeken et al. 2010).

These first results indicate that the developed methodology functions well, especially if it is possible to get rid of the interference in the DIDSON footage, when also automated analysis will be possible. The large dataset that was retrieved within this project will be further analysed in 2017 within the scope of the ongoing DMEC project and additional attempts to get rid of the interference and perform more measurements are foreseen within the this DMEC project also.

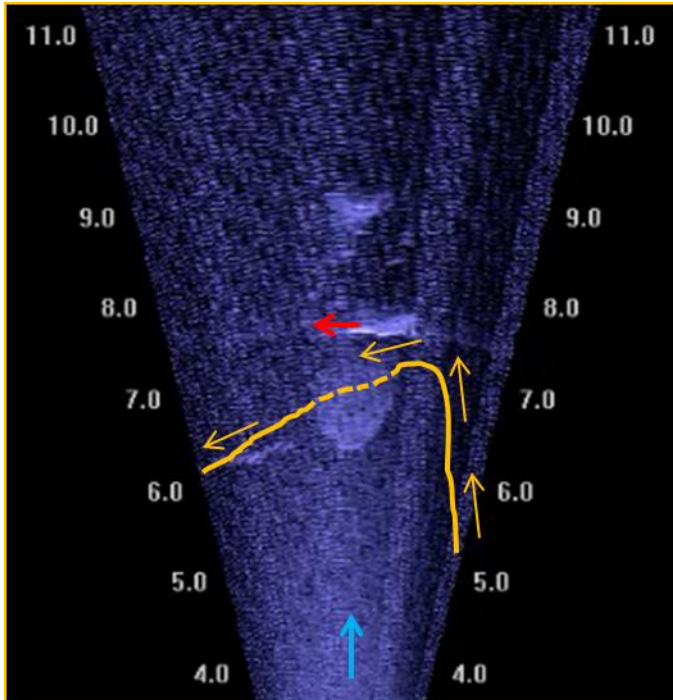

Figure 7.9. The pathway of an eel that approaches the turbine by passively drifting sideways with the water current (flow direction indicated with blue arrow) and when in close approximation of the turbine blade (red arrow indicates direction towards where the blade is moving to) it start to swim away actively at a low angle against the current towards the left (indicated by the orange line and arrows), where it passes underneath the bulb of the turbine (indicated with a dotted orange line).

8 Concluding remarks & recommendations

- The three goals of the project were met, with the remark that by changing the location from a free ranging tidal turbine in the Marsdiep to a tidal turbine test site in the sluices of the Afsluitdijk at Den Oever, chances that the retrieved dataset during the 15 days continuous measurements besides fish will also contain observations of marine mammals (e.g. harbour porpoises or seals) will be neglectably small.
- A robust housing was developed that enabled stable DIDSON measurements without vibrations or malfunctioning in the challenging conditions in which tidal turbines operate, i.e. up to 3-4 m/s, at the test site of Den Oever during continuous measuring for 15 days.
- The power generation from the tidal turbine causes interference in the footage shot by DIDSON that could not be resolved within this pilot study. It is recommended to further discuss and test this with specialized electro-technicians (foreseen to be carried out within the ongoing DMEC project), since this will enhance the possibilities to analyse the data with automated algorithms as developed within this project.
- Algorithms were developed within this project that can be used to automatically analyse DIDSON footage, e.g. select potential fish events that can then further be manually analysed in detail.
- DIDSON technology provides a suitable tool to measure fish behaviour, despite the interference problem, which enables to study the behaviour of fish when approaching a tidal turbine.
- Linking behaviours of fish to the detailed hydrodynamic conditions and other potential cues that influence behaviour such as underwater sound generated by the turbines in relation to the sound scape present and different light conditions is feasible with using the DIDSON and deployment techniques developed within this project.
- The project yielded a large dataset retrieved by recording continuously throughout 19 October – 3 November (15 days) resulting in good footage equalling 366 hours and 4,000 files.
- Future projects that combine behaviour of fishes approaching tidal turbines in combination to environmental conditions and patterns can provide knowledge and measures on minimizing collision rates and provide correction factors for avoidance behaviour in modelling studies aiming to determine collision risks of fish with tidal turbines.

9 References

- Amaral SV, Bevelhimer MS, Čada GF, Giza DJ, Jacobson PT, McMahon BJ, Pracheil BM, (2015). Evaluation of Behavior and Survival of Fish Exposed to an Axial-Flow Hydrokinetic Turbine. *North American Journal of Fisheries Management* 35 (1): 97-113.
- ABP Marine Environmental Research (2010). Projectnr. R/3836/01. Report No. R.1516.
- Broadhurst M, Barr S, Orme CDL (2014). In-situ ecological interactions with a deployed tidal energy device; an observational pilot study. *Ocean & Coastal Management* 99: 31–38.
- Copping A, Battey H, Brown-Saracino J, Massaua M (2014). An international assessment of the environmental effects of marine energy development. *Ocean & Coastal Management* 99: 3-13.
- EPRI (2014). Evaluation of Survival and Behavior of Fish Exposed to an Axial-Flow Hydrokinetic Turbine. EPRI, Palo Alto, Report 3002003911.
- Griffioen AB, Geelhoed SCV, van Keeken OA, Winter HV (2015). Een analyse van de effecten van getijnturbines op habitat, vis, vogels en zeezoogdieren bij Kornwerderzand. IMARES - Report C031/15.
- Hammar L, Andersson S, Eggertsen L, Haglund J, Gullström M, Ehnberg J, Molander S, (2013) Hydrokinetic Turbine Effects on Fish Swimming Behaviour. *PLoS ONE* 8(12): e84141. doi: 10.1371/journal.pone.0084141.
- Melvin GD, Cochrane NA (2015). Multibeam Acoustic Detection of Fish and Water Column Targets at High-Flow Sites. *Estuaries and Coasts* 38 (Suppl. 1): 227-240. doi:10.1007/s12237-014-9828-z
- Reijmerink B, Bijlsma A, (2016). Stroombeeld berekeningen asymmetrisch spuien Afsluitdijk. Deltareport 1221319-000-HYE-0004.
- Romero Gomez PDJ, Richmond MC, (2014a). DISCRETE ELEMENT MODELING OF BLADE-STRIKE FREQUENCY AND SURVIVAL OF FISH PASSING THROUGH HYDROKINETIC TURBINES. In Proceedings of the 2nd Marine Energy Technology Symposium (METS), April 15-18, 2014, Seattle, Washington. Virginia Tech University Libraries, Blacksburg, VA.
- Romero Gomez PDJ, Richmond MC, (2014b). Simulating Blade-Strike on Fish passing through Marine Hydrokinetic Turbines. *Renewable Energy* 71:401-413. doi:10.1016/j.renene.2014.05.051
- Tralli A, Bijlsma AC, te Velde W, de Haas P, (2015). CFD Study on Free-Surface Influence on Tidal Turbines in Hydraulic Structures. Paper OMAE2015-41187, Proc. of the ASME 2015 34th Int. Conf. on Ocean, Offshore and Arctic Engineering, OMAE2015, St. John's, Newfoundland, Canada, May 31-June 5, 2015.
- Viehman HA, Zydlewski GB (2015). Fish Interactions with a Commercial - Scale Tidal Energy Device in the Natural Environment. *Estuaries and Coasts* (2015) 38 (Suppl. 1):S241–S252.
- Van Keeken OA, Burggraaf D, Tribuhl SV, Winter HV, (2010). Gedrag van schieraal rond het krooshek voor gemaal IJmuiden. DIDSON metingen. IMARES Rapport C049/10.

10 Appendix: Technical drawings of the housing design developed by NIOZ for DIDSON measurements at Den Oever.

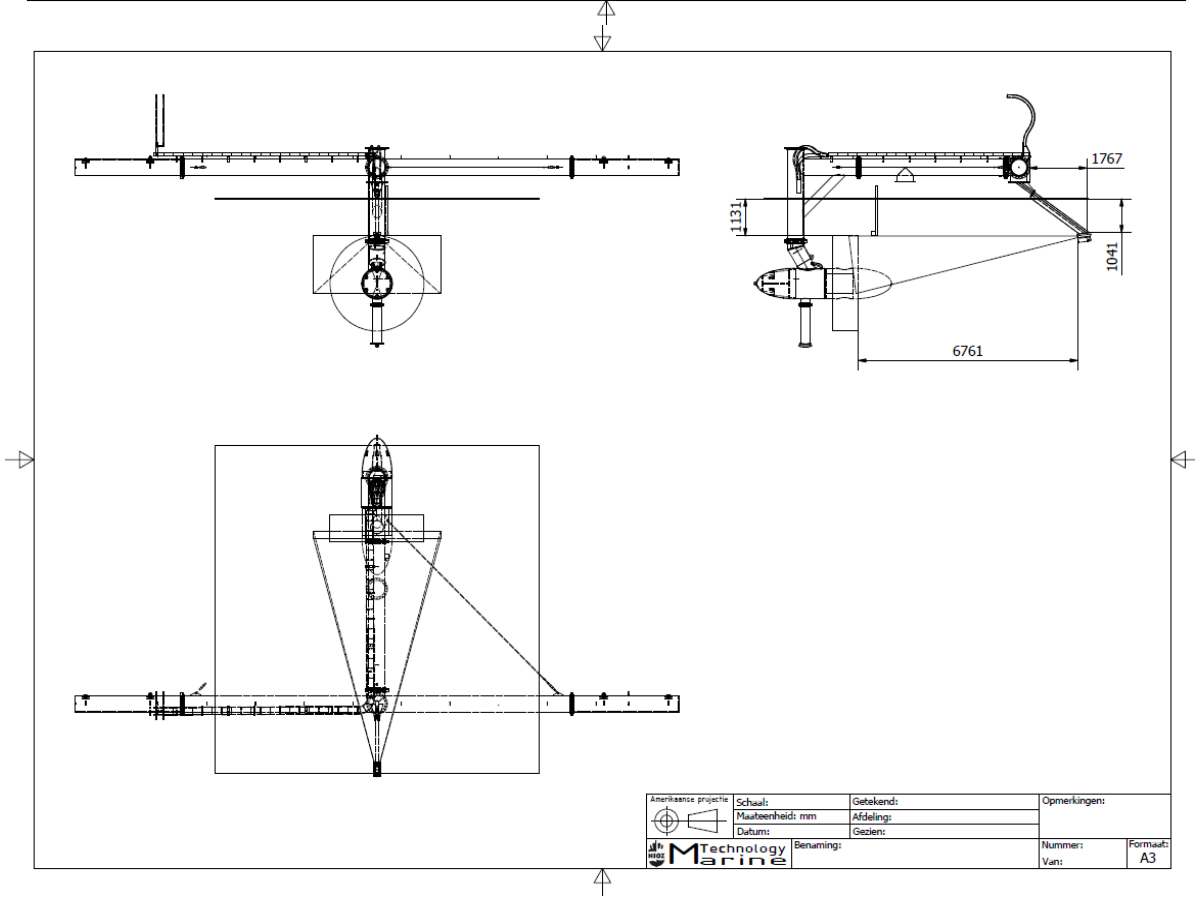
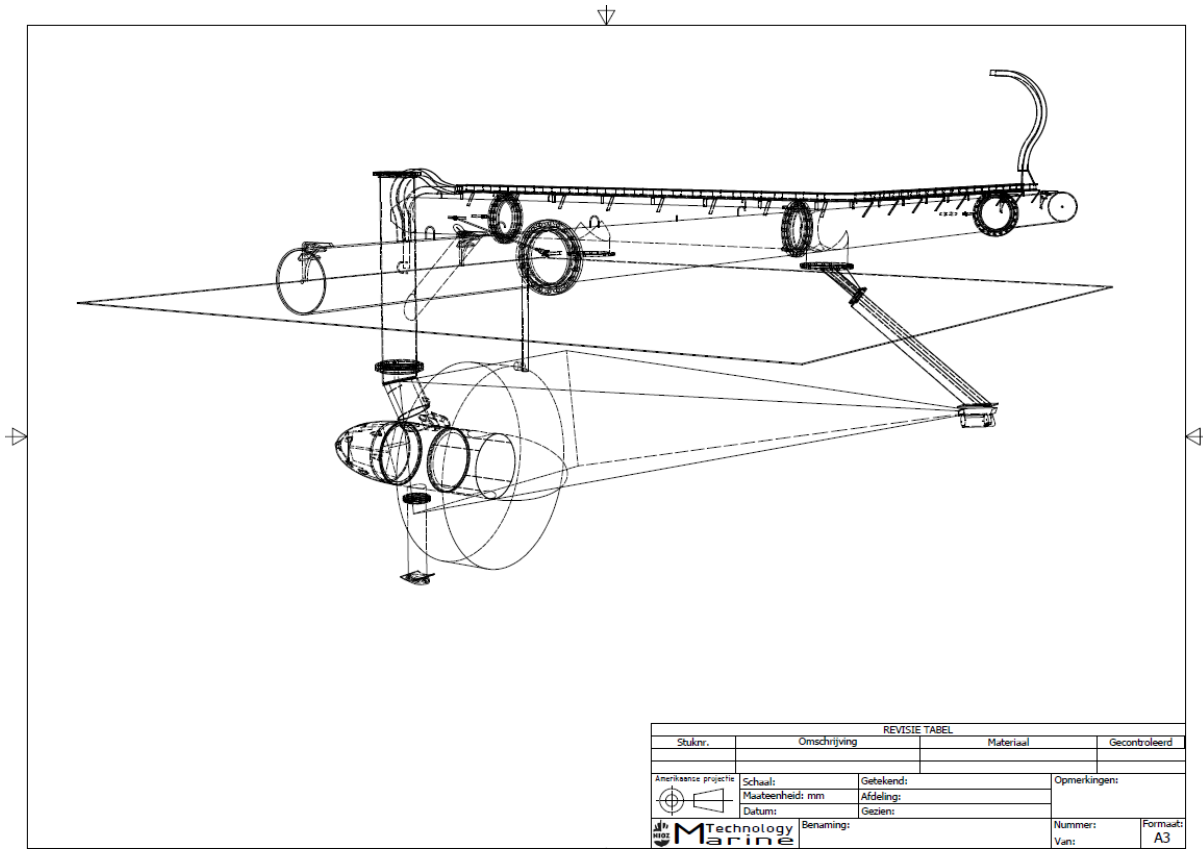

REVISIE TABEL			
Stuknr.	Omschrijving	Materiaal	Gecontroleerd

ITEM	QTY	PART NUMBER	MATERIAL	DESCRIPTION
1	1	Onderste buis	Staal	
3	1	Doos	Staal	
4	1	Bovenste buis	Staal	
5	1	Scharnierpen	Stainless Steel	
6	9	DIN 125 - A 17	Stainless Steel	Wadher
7	2	ISO 4035 - M16	Stainless Steel	Hex Nut
8	4	DIN 913 - M16 x SS	Stainless Steel	Hex-Head Bolt
9	4	DIN 128 - A16	Stainless Steel	Spring Washer
10	4	DIN 934 - M16	Stainless Steel	Hex Nut

Amerikaanse projectie	Schaal:	Getekend: L.Boom	Opmerkingen:
	Maat eenheid: mm	Afdeling: NMF-Support	
	Datum:	Gezien:	
	Benaming: TIDAL FISH IMPACT	Nummer: 1	Formaat: A3
		Van:	

ITEM	QTY	PART NUMBER	MATERIAL	DESCRIPTION
1	1	Scharnierplaat 2	Staal	
2	1	Buis deel 2	Staal	
3	1	Getekerdal 2	Staal	
4	2	Scharnierbus kort	Staal	
5	3	Getekerdal steun	Staal	
6	2	Spanroep	Staal	
7	1	Stoekstrip	Staal	
8	1	Vin lang	Staal	

Amerikaanse projectie	Schaal:	Getekend:	Opmerkingen:
	Maat eenheid: mm	Afdeling:	
	Datum:	Gezien:	
	Benaming:	Nummer:	Formaat: A3
		Van:	

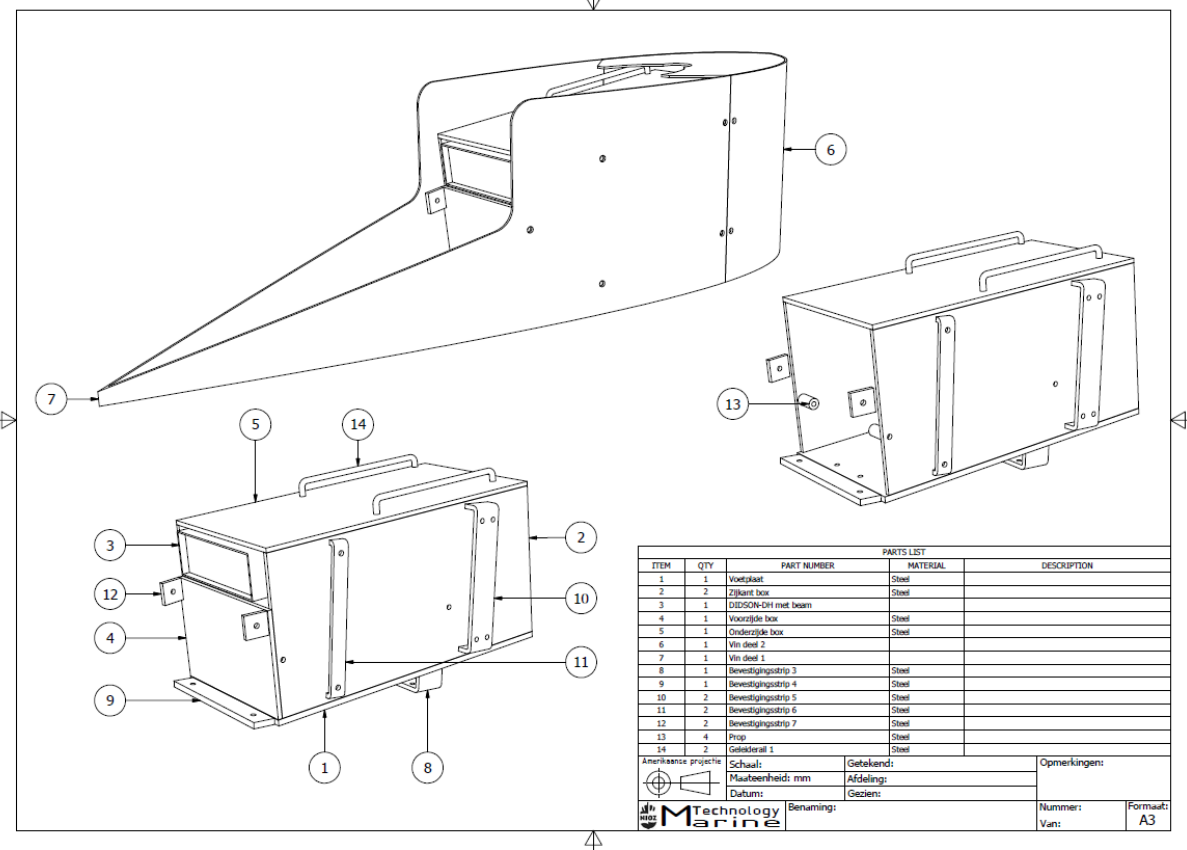
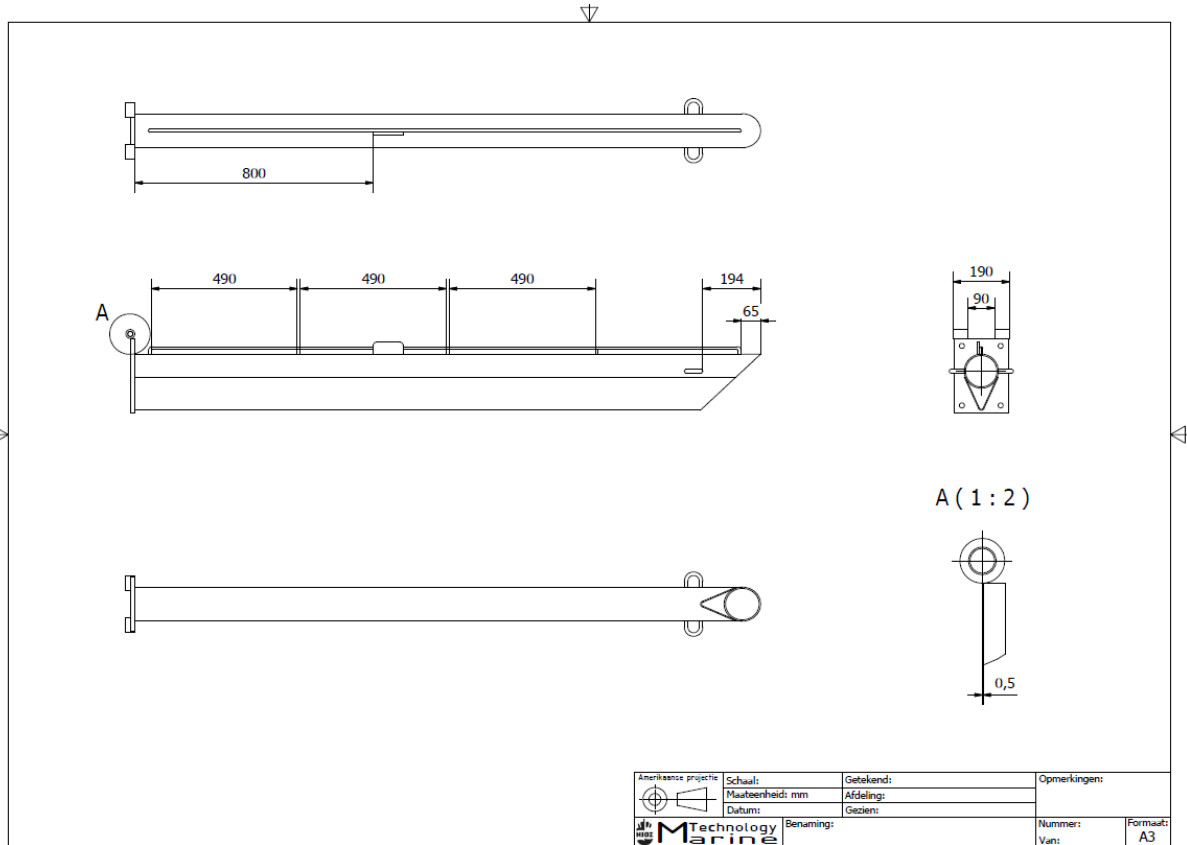

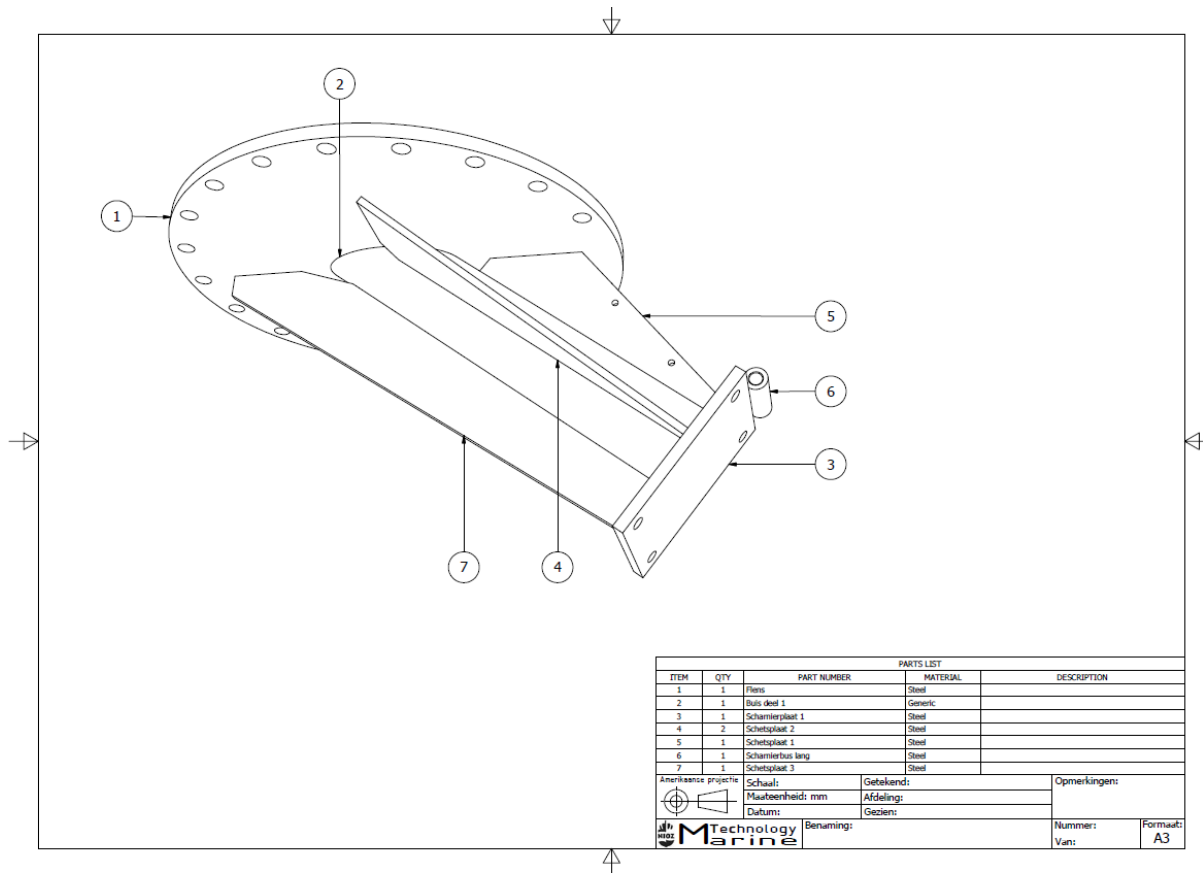

PARTS LIST				
ITEM	QTY	PART NUMBER	MATERIAL	DESCRIPTION
1	1	Flens	Staal	
2	1	Buis deel 1	Generic	
3	1	Scharnierplaat 1	Staal	
4	2	Scheepsplaat 2	Staal	
5	1	Scheepsplaat 1	Staal	
6	1	Scharnierbus lang	Staal	
7	1	Scheepsplaat 3	Staal	

	Amerikaanse projecten	Schaal:	Getekend:	Opmerkingen:
		Maatteenheid: mm	Afdeling:	
		Datum:	Gezien:	
		Benoeming:		
			Nummers:	Formaat:
			Vers:	A3